

Energiepolitik und Klimaschutz.  
Energy Policy and Climate Protection

RESEARCH

Sebastian Groh · Lukas Barner ·  
Georg Heinemann ·  
Christian von Hirschhausen *Editors*

# Electricity Access, Decarbonization, and Integration of Renewables

Insights and Lessons from the Energy  
Transformation in Bangladesh, South  
Asia, and Sub-Saharan Africa

OPEN ACCESS



Springer VS

---

# **Energiepolitik und Klimaschutz.**

## **Energy Policy and Climate Protection**

### **Series Editors**

Lutz Mez, Berlin Centre for Caspian Region Studies, Freie Universität Berlin,  
Berlin, Berlin, Germany

Achim Brunnengräber, Environmental Policy Research Centre, Freie Universität  
Berlin, Berlin, Germany

**Diese Buchreihe** beschäftigt sich mit den globalen Verteilungskämpfen um knappe Energieressourcen, mit dem Klimawandel und seinen Auswirkungen sowie mit den globalen, nationalen, regionalen und lokalen Herausforderungen der umkämpften Energiewende. Die Beiträge der Reihe zielen auf eine nachhaltige Energie- und Klimapolitik sowie die wirtschaftlichen Interessen, Machtverhältnisse und Pfadabhängigkeiten, die sich dabei als hohe Hindernisse erweisen. Weitere Themen sind die internationale und europäische Liberalisierung der Energiemärkte, die Klimapolitik der Vereinten Nationen (UN), Anpassungsmaßnahmen an den Klimawandel in den Entwicklungs-, Schwellen- und Industrieländern, Strategien zur Dekarbonisierung sowie der Ausstieg aus der Kernenergie und der Umgang mit den nuklearen Hinterlassenschaften.

Die Reihe bietet ein Forum für empirisch angeleitete, quantitative und international vergleichende Arbeiten, für Untersuchungen von grenzüberschreitenden Transformations-, Mehrebenen- und Governance-Prozessen oder von nationalen „best practice“-Beispielen. Ebenso ist sie offen für theoriegeleitete, qualitative Untersuchungen, die sich mit den grundlegenden Fragen des gesellschaftlichen Wandels in der Energiepolitik, bei der Energiewende und beim Klimaschutz beschäftigen.

**This book series** focuses on global distribution struggles over scarce energy resources, climate change and its impacts, and the global, national, regional and local challenges associated with contested energy transitions. The contributions to the series explore the opportunities to create sustainable energy and climate policies against the backdrop of the obstacles created by strong economic interests, power relations and path dependencies. The series addresses such matters as the international and European liberalization of energy sectors; sustainability and international climate change policy; climate change adaptation measures in the developing, emerging and industrialized countries; strategies toward decarbonization; the problems of nuclear energy and the nuclear legacy.

The series includes theory-led, empirically guided, quantitative and qualitative international comparative work, investigations of cross-border transformations, governance and multi-level processes, and national “best practice”-examples. The goal of the series is to better understand societal-ecological transformations for low carbon energy systems, energy transitions and climate protection.

**Reihe herausgegeben von**

PD Dr. Lutz Mez  
Freie Universität Berlin

PD Dr. Achim Brunnengräber  
Freie Universität Berlin

---

Sebastian Groh · Lukas Barner ·  
Georg Heinemann ·  
Christian von Hirschhausen  
Editors

# Electricity Access, Decarbonization, and Integration of Renewables

Insights and Lessons from the Energy  
Transformation in Bangladesh, South  
Asia, and Sub-Saharan Africa

 Springer VS

*Editors*

Sebastian Groh  
Brac Business School (BBS)  
BRAC University  
Dhaka, Bangladesh

Lukas Barner  
Fachgebiet Wirtschafts- und Infrastruk-  
turpolitik, Technical University of Berlin  
Berlin, Germany

Georg Heinemann  
Fachgebiet Wirtschafts- und Infrastruk-  
turpolitik, Technical University of Berlin  
Berlin, Germany

Christian von Hirschhausen  
Fachgebiet Wirtschafts- und Infrastruk-  
turpolitik, Technical University of Berlin  
Berlin, Germany



ISSN 2626-2827

ISSN 2626-2835 (electronic)

Energiepolitik und Klimaschutz. Energy Policy and Climate Protection

ISBN 978-3-658-38214-8

ISBN 978-3-658-38215-5 (eBook)

<https://doi.org/10.1007/978-3-658-38215-5>

© The Editor(s) (if applicable) and The Author(s) 2023. This book is an open access publication. **Open Access** This book is licensed under the terms of the Creative Commons Attribution 4.0 International License (<http://creativecommons.org/licenses/by/4.0/>), which permits use, sharing, adaptation, distribution and reproduction in any medium or format, as long as you give appropriate credit to the original author(s) and the source, provide a link to the Creative Commons license and indicate if changes were made.

The images or other third party material in this book are included in the book's Creative Commons license, unless indicated otherwise in a credit line to the material. If material is not included in the book's Creative Commons license and your intended use is not permitted by statutory regulation or exceeds the permitted use, you will need to obtain permission directly from the copyright holder.

The use of general descriptive names, registered names, trademarks, service marks, etc. in this publication does not imply, even in the absence of a specific statement, that such names are exempt from the relevant protective laws and regulations and therefore free for general use.

The publisher, the authors, and the editors are safe to assume that the advice and information in this book are believed to be true and accurate at the date of publication. Neither the publisher nor the authors or the editors give a warranty, expressed or implied, with respect to the material contained herein or for any errors or omissions that may have been made. The publisher remains neutral with regard to jurisdictional claims in published maps and institutional affiliations.

Responsible Editor: Stefanie Eggert

This Springer VS imprint is published by the registered company Springer Fachmedien Wiesbaden GmbH, part of Springer Nature.

The registered company address is: Abraham-Lincoln-Str. 46, 65189 Wiesbaden, Germany

---

## A Foreword from Bangladesh

*Additional Secretary and Chairman of the Sustainable and Renewable Energy Development Authority (SREDA) under the Bangladesh Power Division, Ministry of Power, Energy & Mineral Resources, Government of Bangladesh.*

As Chairman of the Sustainable and Renewable Energy Development Authority (SREDA), it is my pleasure to introduce this book, and to congratulate all that have contributed to its creation. The Government of the People's Republic of Bangladesh enacted the 'Sustainable and Renewable Energy Development Authority' (SREDA) Act-2012 to reduce global warming, environmental hazard risk and to ensure energy security by reducing the dependency on fossil fuel through the use and expansion of Renewable Energy. The Authority also aims at preventing energy waste in residential, commercial & industrial sectors by saving and conserving energy as well as ensuring its efficient use. SREDA has started its journey in 2014 with its mission to ensure energy security with building an energy conscious nation through the promotion of sustainable energy and reducing carbon emission.

There are many good reasons to have held a conference on the topics of Electricity Access, Decarbonization, and the Integration of Renewables, and now to subsequently publish this important book. As a representative of the Government of Bangladesh, let me focus on this country, while acknowledging other experiences that are addressed in this publication.

Bangladesh enjoys a sizeable amount of sunshine. Here, the average solar radiation varies between 4 and 6.5 kilowatt-hour (kWh) per square metre per day. Tapping into solar energy, Bangladesh has been able to provide access to electricity to over 12% of its population outside the grid network through the installation of more than six million solar home systems. Despite a huge potential, however, consumers of grid-connected electricity are yet to exploit the power of the sun to

their advantage. The fact is, every on-grid household and commercial establishment can utilize solar energy in a decentralized manner to generate electricity by installing solar photovoltaic (PV) panels on their rooftops and become electricity producers, meeting their electricity demand partly or fully by themselves, and even selling excess electricity to the distribution utilities through net metering.

In Bangladesh, where securing land for ground-mounted, large-scale solar power generation poses a huge challenge, a more decentralized approach can be a good choice to incentivise solar power generation on rooftops. Thus, the transformation of electricity consumers into producers will result in significant renewable electricity generation, reducing government investment in the sector, and helping attain energy security for the country.

Bangladesh is embarking on a new journey after the recent confirmation of its graduation from the least developed countries. This is a massive success for the country coinciding with its 50 years celebration of independence. On this new journey, the country needs to reduce its dependency on fossil fuels and raise its share in renewables. Bangladesh aimed for 10% generation from renewables (approx. 2,400 MW) by 2020 originally, but is only likely to reach that target by 2025. The current share is about 3%. At the end of the day, it is the economics which determine the expansion of any technology. Solar is one of the most cost-competitive sources of power in the country. For industrial users, rooftop solar costs a third or less than the grid tariff, which can be as high as 12 U.S. cents per unit. The ambition is to produce 40% electricity from renewable sources by 2041. For this to happen, more innovation on business models, technology such as distributed storage and generation as well as policy reforms are required. I am grateful for this undertaking to have made suggestions in this direction. Further, increased access to international funding is needed. The Honourable Prime Minister of Bangladesh, Sheikh Hasina, who is also presently the chair of the Climate Vulnerable Forum (CVF), a group of 48 countries spanning four continents, has stressed the need to increase financing for ensuring survival of the most vulnerable countries from the adverse impact of climate change. In particular she called for materializing developed countries' climate promises of \$100 billion in annual funding to developing countries for their survival.

I hope this book will help us and the world to see a sustainable energy future, through decentralized renewable energy solutions.

Mohammad Alauddin

---

## A Foreword from Germany

Welcome to this important book. It is a particular pleasure for me to contribute a foreword because I am personally involved in all of the issues raised and can testify that they are important.

I am a Special Representative for Energy in Africa, and Chair of the Global Renewables Congress, a network of parliamentarians, who support renewable energies. In these two functions, I am building up renewable energy projects and help Parliamentarians who campaign for renewable energies.

---

### **My First Visit to Bangladesh (2019)**

In October/November 2019, I visited Bangladesh, because I was interested to learn from this country. Bangladesh is the country with the highest number of Solar Home Systems (SHS) in the world and I wanted to know, how the government managed to achieve this. Its Infrastructure Development Company Ltd. (IDCOL) is an institution that has set up very efficient and decentralized structures, set quality standards for mini grids and has offered funding for this purpose. That is interesting to me and my work in Africa, because we are always looking for good examples whose ideas are transferable.

German NGOs have organized an exchange of representatives a few years ago between Bangladesh and East African countries to benefit from the experience of Bangladesh. We now see that decentralized renewable energies are more widespread in East Africa than in West Africa and that access to energy is the driver for combating hunger and poverty, especially in rural areas.

Bangladesh also features special off-grid solutions such as the peer-to-peer connections that are implemented by the solar company Solshare with CEO



Sebastian Groh, who co-edits this book. The technology is interesting because it is very efficient and can be used particularly if there are already many SHS systems in a village and these are then to be connected to a more powerful and efficient village network.

---

## **SDG7 as an Instrument to Achieve Other Sustainable Development Goals**

It is our common target to achieve the 17 sustainable developments goals until 2030. Leave no one behind. Worldwide 900 million people lack access to energy. Because there is no clean cooking situation three billion people are suffering from eye and lung diseases from the smoke, in particular women and children. In addition, however, energy is a necessary basis for every country in the world to improve people's living conditions. Where would the industrialized countries stand without electricity and energy?

SDG 7 is not just a sustainability goal itself; it is an instrument to better achieve 2/3 of the other sustainability goals.

With energy you can dry the fruits and vegetables, grind the grain, cool the fish and thus can combat hunger and poverty (SDG 1, SDG 2). Energy means more income.

With electricity you can bring your harvest to the next market and run a small craft or a shop. You can create new jobs and economic growth (SDG 8).

Further, energy allows you to have better health and educational systems, for example by powering electric lighting or cooling units for medication (SDG 3, SDG 4).

With renewable energies you can operate water wells by replacing previous diesel pumps, while doing so in a climate friendly manner and saving a lot of money since diesel is much more expensive (SDG 6).

Decentralized energies, especially SHS promote women (SDG 5). Contracts are often preferably concluded with women, as they are expected to be more reliable partners. This gives them the option to earn additional income, for example by charging cell phones of their neighbors.

Small decentralized renewable energies are also less prone to corruption than large power plants and the associated nationwide grids (SDG 9).

---

## **Renewables and Two Crises: Pandemic and Climate**

In fact, we currently have two crises to overcome: the pandemic and the climate crisis. The Global Renewables Congress (GRC) network of parliamentarians, of which I am chairperson, has compared the effects of the Covid-19 pandemic amongst different countries and how these have tried to overcome the crisis. Many countries that relied on coal imports have noticed the disruption of supply chains during the pandemic.

Renewable energies make countries more resilient because sun and wind are also present in pandemic times. Nevertheless, we found that in the stimulus packages to compensate for the impacts of the pandemic, renewables are still under-represented.

---

## **Reforms Require Political will**

To transform energy, we need an exchange of good ideas and an open culture of debate regarding all issues.

If we are looking for decentralized renewable energy solutions, the people in rural areas must take responsibility, they must be trained and empowered. The people have to be involved in local energy projects.

In conclusion, let me finish with another reference to my political experience in Germany: The most important point in achieving the energy transformation is political will. Electricity access and the energy transformation are important topics to debate together, as done in this book. I wish it a lot of success!

Bärbel Höhn  
Special Representative for Energy in Africa of  
the Federal Ministry for Economic Cooperation and  
Development in Germany  
Berlin  
Germany

---

# Contents

<b>Electricity Access, Decarbonization, and Integration of Renewables: Insights and Lessons from the Energy Transformation in Bangladesh, South Asia, and Sub-Saharan Africa. . . .</b>	<b>1</b>
Sebastian Groh, Lukas Barner, Raluca Dumitrescu, Georg Heinemann und Christian von Hirschhausen	
<b>Powering up a Country into the Middle-Income Club . . . . .</b>	<b>21</b>
Sakib Amin, Ahsan H. Mansur, Syed Mafiz Kamal und Sebastian Groh	
<b>100 % Electrification but What Comes Next for Bangladesh? Lessons from Insiders . . . . .</b>	<b>53</b>
Nancy Wimmer	
<b>Policy Options While Increasing Share of Renewable Energy: Technology Choices for Peaking Power in the Context of Bangladesh. . . . .</b>	<b>67</b>
Riya Roy, Abdullah Al Jubayer, Kazi Sadman Sakib, Najmus Sakib, Avijit Saha, M. Rezwan Khan und M. Shahedul Alam	
<b>Low-Carbon Energy Transformation in China, India, Pakistan, and Afghanistan: An Overview . . . . .</b>	<b>87</b>
Abdullah Fahimi und Kai Stepputat	
<b>Consequences of Lockdown Due to COVID-19 on the Electricity Generation and Environment in South Asia. . . . .</b>	<b>113</b>
Shameem Hasan, Mirza Rasheduzzaman und M. Mofazzal Hossain	

<b>Integrating Wind and Solar in the Indian Power System . . . . .</b>	<b>139</b>
Neshwin Rodrigues, Raghav Pachouri, Shubham Thakare, G. Renjith und Thomas Spencer	
<b>Decentralized Electrification Pathways in Sub-Saharan Africa—Assessment of Experiences and Business Models . . . . .</b>	<b>163</b>
George Arende und Sofia Gonçalves	
<b>Identifying Effective Electrification Approaches and Combinations Thereof to Meet Universal Electricity Access Targets in Eastern Africa . . . . .</b>	<b>177</b>
Charles Muchunku und Georg Heinemann	
<b>Are Mini-Grid Projects in Tanzania Financially Sustainable? . . . . .</b>	<b>233</b>
Elias Zigah, Mamadou Barry und Anna Creti	
<b>Establishing Local Power Markets and Enabling Financial Access to Solar Photovoltaic Technologies: Experiences in Rural Tanzania . . . . .</b>	<b>263</b>
Guglielmo Mazzà, Marco Pasini, Silvia Ricci, Matthew Matimbwi und Giampietro Pizzo	



---

# Electricity Access, Decarbonization, and Integration of Renewables: Insights and Lessons from the Energy Transformation in Bangladesh, South Asia, and Sub-Sahara Africa

Sebastian Groh, Lukas Barner, Raluca Dumitrescu, Georg Heinemann and Christian von Hirschhausen

---

## Abstract

This chapter provides an introduction to the book, identifies different perspectives, and describes the different sections of the book in more detail. It places the research issues in the context of the “great socio-ecological transformation” and defines different elements of this process. The chapter also includes the main take-away messages from subsequent book chapters.

---

L. Barner · G. Heinemann (✉) · C. von Hirschhausen  
Fachgebiet Wirtschafts- und Infrastrukturpolitik, Technische Universität Berlin,  
Berlin, Germany

e-mail: [gh@wip.tu-berlin.de](mailto:gh@wip.tu-berlin.de)

C. von Hirschhausen

e-mail: [cvh@wip.tu-berlin.de](mailto:cvh@wip.tu-berlin.de)

S. Groh

Brac Business School (BBS), BRAC University, Dhaka, Bangladesh

e-mail: [sebastian.groh@bracu.ac.bd](mailto:sebastian.groh@bracu.ac.bd)

R. Dumitrescu

Microenergy International, Berlin, Germany

e-mail: [raluca.dumitrescu@microenergy-systems.de](mailto:raluca.dumitrescu@microenergy-systems.de)

© The Author(s) 2023

S. Groh et al. (eds.), *Electricity Access, Decarbonization, and Integration of Renewables*, Energiepolitik und Klimaschutz. Energy Policy and Climate Protection, [https://doi.org/10.1007/978-3-658-38215-5\\_1](https://doi.org/10.1007/978-3-658-38215-5_1)

---

**Keywords**

Bangladesh · Electricity Access · Energy Transformation · Renewables · South Asia · Sub-Sahara Africa

---

## 1 Preface

As renewables-based energy transformations are accelerating world-wide, progress can be reported and analyzed from a variety of countries, including from the Global South. This book covers different aspects of the low-carbon energy transformation, with a particular focus two regions, South Asia, and Sub-Sahara Africa, and on one country, Bangladesh. The book results from an international conference, organized by Brac University (Dhaka, Bangladesh), Carnegie Mellon University (Pittsburgh, PA, USA), and Technische Universität Berlin (Germany), and held (digitally) out of Dhaka (Bangladesh) and Berlin (Germany), on March 2–4, 2021. Given that the conference coincided with the 50<sup>th</sup> Anniversary of independence in Bangladesh, a focus of the book lies on this country and on South Asia in general, but experiences and lessons from Sub-Sahara Africa are also featured, enabling cross-country and cross-regional comparisons. This introduction provides a discussion of the major research issues surrounding these topics, surveys some existing literature, and then describes how the chapters contribute to the debate.

---

## 2 The low-carbon energy transformation

As a methodological point of inception, we see the topics of electricity access and renewable integration as part of the socio-ecological low-carbon energy transformation, that is now ongoing in all regions of the world. Driven by the need to reduce the emissions of greenhouse gases, but also of technically and socially acceptable transformation pathways towards stronger citizen involvement, the “great transformation” (WBGU, 2011) knows no borders, and it is present in all corners of the globe, and of the energy system.

There is no consistent framework that would define the borders of what is being “transformed”, neither is the objective of the transformation process itself being precisely defined. It can be assumed that energy policies are largely national policies, and that they play out at the local level once it comes to electricity access, so focus on comparative analysis in two regions is justified (here: South Asia, complemented by Sub-Sahara Africa). Also, a focus on the Global South is pre-set by

the central issue, electricity access, even though other topics, such as renewable integration and grid issues, are certainly relevant in the context of the Global North, too, under quite different regulatory and institutional preconditions.

One way of summarizing the challenges of the great transformation is to see it as a combination of the four D's: Decarbonization, decentralization, digitization, and democratization.<sup>1</sup> In fact, decarbonization as a requirement to abate the climate crisis is a central element, but only one. Decentralization of production and consumption structures is another element of the transformation, given that electricity access is by nature a process targeting industrial and household users that are often dispersed geographically and socially, and thus competition between organizational models of providing it is useful (Karplus & von Hirschhausen, 2019). Along these lines, democratization includes more balanced decisions and the option (not the obligation) of energy users to get involved in decisions on production and distribution as well. The first three D's are sometimes said to be derived from Amory Lovins' (Lovins, 1976, 1979) "soft path" of energy reform, providing, amongst others, a perspective for the energy transformation in Germany, called *Energiewende* (Krause et al., 1980; von Hirschhausen et al., 2018). Add digitization, which is nowadays a must, where electricity is often coordinated, traded, and paid by means of digital (mobile-based) services.

Thus, major reforms in this transformation context are taking place at different levels:

- The country level, where energy mixes are rapidly changing,
- the corporate level, where large state-owned and private companies are challenged and new actors are emerging,
- and the local level, where technical and regulatory change has made citizen engagement and community power an option to replace or at least complement central supply structures.

The contributions to this book combine all three levels. National policies and (climate and other) targets are key drivers, whereas different organizational models for corporate adaptation exist. Clearly the local level is always present when it comes to access issues, thus the three layers interact closely. Cross-country chapters, mainly on South Asia, complement the picture.

---

<sup>1</sup> See also <https://www.weforum.org/agenda/2018/06/rural-bangladesh-villages-transition-renewable-energy-sebastian-groh/>, where disruption is mentioned as an additional D.

### 3 Focus on electricity access, decarbonization, and integration of renewables

The contributions in this book focus on different aspects of the low-carbon energy transformation by especially taking a micro-level perspective as well as emphasizing the role of decentralized renewable energy solutions (DREs).<sup>2</sup> The flexible and cost-effective deployment of DREs addresses the specific requirements of local households which depend on the respective urban, peri-urban, or rural contexts (Puig et al., 2021).

Furthermore, electricity access and decarbonization have been important topics in international development and sustainability discussions. The United Nations' "Agenda 2030" includes electrification as a goal for sustainable development (Sustainable Development Goal number 7 (SDG7)). It combines the demand for universal access to energy with the expansion of renewable energies.<sup>3</sup> And access is not only needed for individual basic supply, but it is also a key factor in the provision of social services such as education and health, as well as a key added-value component for all sectors of the economy.

Over the past two decades, significant progress has been made in terms of access to electricity in the Global South. In 2015, more than one billion people had no access to electricity (IEA et al., 2018), by 2019 this figure had decreased to approximately 770 million (World Bank, SE4ALL database, 2020b). All in all, the global electrification rate has increased by 12% since the start of the millennium, even despite continued population growth. Significant progress has been especially made in South and East Asia: Around 92% of the population have access to electricity, compared with only 55% in 2001. But the ongoing Covid-19 pandemic shows that the process of electrification is more fragile than assumed. IEA et al. estimate that for the first time in a long while the number of people lacking access to electricity has increased by 30 million (IEA et al., 2021). And global distribution of these developments is highly

---

<sup>2</sup>DRE systems or applications are small-scale electricity producing units powered by renewable energy sources that supply power to local consumers at or near the side of generation. The electricity producing units may be stand-alone or connected to other generation systems nearby via a grid network. Compared to conventional centralized power generation systems, DREs are a cost-effective way to facilitate rapid deployment and access to electricity to consumers that are not connected to the national grid or that need a steady and reliable power supply (von Hirschhausen et al., 2020).

<sup>3</sup>In addition to sub-goal 7.1 ("universal access to affordable, reliable and modern energy"), sub-goal 7.2 calls for a "substantial increase in the share of renewable energy in the global energy mix".



uneven. In Europe, North America, and developed countries in the Asia-Pacific region an electrification rate of almost 100% rate has been achieved. On the other hand, the African continent as well as some individual countries in Asia and Latin America continue to have low electrification rates. And particularly the gap between rural and urban areas is large. While around 97% of the world's urban areas are supplied with electricity, this figure amounts to only 82% in rural areas. In sub-Saharan Africa, this gap is even more pronounced: 78% of urban users have access to electricity, compared to only 32% in rural areas (World Bank, SE4ALL database, 2020a).

In case of high population density grid extension is easier and more cost-effective. When comparing the option of electrifying rural areas through DRE with the option of extending public electricity grids, experience reveals that standard grid electrification often fails to meet the objective of securing the provision of reliable access to electricity. Grid extension also takes longer and requires a higher investment. Although higher power generation capacities are provided, the reliability of the electricity supply might be compromised by decreased reliability due to a weak grid infrastructure (von Hirschhausen et al., 2020).

DREs have several direct advantages over grid extensions and public grids due to their modular and cost-effective nature, particularly in rural areas. They mobilize national and international resources (including capital), increase energy security and efficiency, and generate new revenues for the local population. The indirect advantages of DREs positively impact individual households as well as communities leading to regional knowledge transfer and capacity building and may also encourage local and national research and innovation (Ferrall et al., 2021).

DRE solutions result in electricity producing facilities being located closer to where their output is consumed. DREs make better use of local renewable energy sources and combined heat and power solutions, as well as decreasing fossil fuel use. They further reduce environmental impacts and economic costs by minimizing transmission and distribution inefficiencies (Heinemann et al., 2020).

Technological advances and significant declines in cost over the past decade have led to the addition of DRE as a feasible low-cost option to electrification in many countries.<sup>4</sup> For example, the levelized costs of energy (LCOE) of solar photovoltaic (PV) power has fallen by 85%, from EUR 0.33 to EUR 0.05 per kWh and the LCOE for wind energy has fallen by 56%, from EUR 0.07 to EUR 0.03 per kWh (IRENA, 2021).

---

<sup>4</sup>DRE solutions, powered by technologies such as solar PV, hydro power, biogas plants, and wind turbines, include both mini-grid and off-grid systems. Mini-grids are local grids that are separate from the national power grid. They are used to provide energy access to regions not served by the grid, particularly in hard-to-reach areas. Off-grid systems are independent standalone systems for households or businesses.

The total costs to achieve universal electricity access by 2030 are estimated generally as affordable. For example, the International Energy Agency (IEA) estimates that the investment required will be only 35 billion U.S. dollars per year (IEA, 2020). While a large share of electrification progress in recent years can still be attributed to public grid extensions, the share of DRE is increasing steadily. As research shows, DRE is not a stopgap, but rather the optimal long-term supply option, especially in remote areas (Blechinger et al., 2019; IEA, 2017).

Accordingly, the contributions in this book will focus on these different aspects of the low-carbon energy transformation by especially taking a micro-level perspective, where in fact multiple transformations are ongoing. The main aspects can be briefly summarized as follows:

- electricity access, rapidly advancing in many countries and regions, but still facing challenges with a view on attaining the sustainable development goals (SDGs), specifically SDG 7, affordable, reliable, and largely renewable energy access by 2030 (United Nations, 2015; Groh et al., 2016; Karplus & von Hirschhausen, 2019). Another interesting issue is what happens when a country reaches near full electrification (e. g., India and Bangladesh). What is the role of integrated electrification pathways?<sup>5</sup> Is there still a place for micro-grids?
- decarbonization, i. e., a broad movement to abandon fossil fuels at the global scale. While decarbonization was still a wild dream of environmentalists only two decades ago, it has now entered mainstream thinking even in more conservative circles of the energy world, such as the International Energy Agency (IEA, 2020).
- renewable energies, as the large-scale solution to access and decarbonization, though still underdeveloped and requiring a systems approach due to the (small) size and the intermittency of its operations (Papaefthymiou & Dragoon, 2016; Oei et al., 2020; Bogdanov et al., 2021).

Needless to mention that other important topics are less represented in the analysis, such as non-electricity issues and cooking, or the role of technology transfer in these processes. Almost all chapters refer to SDG7, but we do not explore conceptually new ground in this matter, and refer to companion papers (Groh et al., 2016; Pelz et al., 2022).

---

<sup>5</sup> See *Sustainable Energy for All* for further information: <https://www.seforall.org/interventions/electricity-for-all-in-africa/integrated-electrification-pathways>.

## 4 Structure of the book

### 4.1 Introduction and welcome addresses

The book is divided into an introductory section and three main parts. The introductory part includes the opening remarks and welcome addresses by Mohammad Alauddin, chairman of SREDA, the Sustainable and Renewable Energy Development Authority of Bangladesh, and Bärbel Höhn, special representative for Energy in Africa of the German Federal Ministry for Economic Cooperation and Development (BMZ). Alauddin provides a particular focus on issues of access and renewable energy supply in Bangladesh, whereas Höhn, mainly active in Africa, links Bangladesh and South Asia to Africa, drawing up similarities and differences between both regions. After this overall “Introduction” (Chap. 1), the following three parts of the book unfold:

### 4.2 *Part I: Energy Sector Reform in Bangladesh@50*<sup>6</sup>

Part I of the book addresses the unique energy sector reform in Bangladesh, as the country attempts sustainable development as a middle-income country. In fact, the rise from Henry Kissinger’s basket case, a civil war and poverty shaken, newly independent country in 1971, to one of the powerhouses of Asia in the 2020s, is remarkable. This development has relied largely on extensive growth, though, and was fuelled by fossil fuels, mainly natural gas. In Chap. 2, Ahsan Mansur, Director of the Institute of Policy Studies in Bangladesh, and former Economist with the International Monetary Fund (IMF), and colleagues, report on the economic reforms in the country, and the role of energy in this process: “Powering up a country into the middle-income club—the story of Bangladesh”. The country has succeeded in catching up over the last decades, coming to near full electrification, however, questions about the sustainability of the reforms remain, especially in times of the COVID-19 pandemic where significant overcapacity in electricity generation capacity coupled with continuous load shedding

---

<sup>6</sup>March 26, 2021, marked 50 years since the start of Bangladesh’s liberation war, a bloody nine-month campaign that culminated in the nation’s independence on December 16, 1971. In 2021, under the slogan *Bangladesh@50*, the country is celebrating its 50th anniversary of independence, see <https://thediplomat.com/2021/02/bangladesh-at-50-the-transformation-of-a-nation/>.

and large financial losses of public utilities via extensive subsidies for fossil fuels have thrown up a few doubts.

On the other hand, however, Bangladesh excels as the world's champion of decentral electrification, through solar home systems (SHS), and has shown that swarm electrification, i. e., the interconnection of very small solar home systems, can work. While this story has been told at various occasions, there is no more comprehensive account than the one provided by Nancy Wimmer, advisor to the World Council for Renewable Energy and Director of microSOLAR, in her two books on "Green Energy for a Billion Poor" (Wimmer, 2012), and "Marketmakers: Solar for the Hinterland of Bangladesh" (Wimmer, 2019). Based on a conversation with some of the founding personalities of the world's largest decentralized electrification program, Nancy Wimmer summarizes the experience with SHS deployment and provides an outlook for the challenges lying ahead: "100% electrification—What comes next for Bangladesh?" (Chap. 3). In 2002, when over 70% of the country's rural population had for generations never known electric light, the most dynamic off-grid electrification program in the world was launched, and it became a success story: Within a decade, Bangladesh was on its way to becoming the world's fastest growing off-grid solar market; today, over 5 million systems have been deployed. However, now that over 90% of the households of Bangladesh have access to electricity, what role will solar technology play in the future? Will the solar market move away from SHS towards grid-connected distributed renewable energy systems?

Chapter 4 brings together the issue of decarbonization and renewable energy technologies "Exploring policy options for increasing the share of renewable energy: Technology Choices for Peaking Power in the Context of Bangladesh". Rezwana Khan (United International University), Shahedul Alam (North South University) and colleagues address an issue well-known in the low-carbon energy transformation: Fossil-fuel power plants suffer from high costs and low peak-load capacity utilization. The paper examines different technological choices and existing opportunities in the local context. Different types of storage solutions are discussed, as are "hybrid" solutions where renewable infeed is backed up by traditional fuels.

### **4.3 Part II: Low-carbon energy transformation in South Asia**

Part II covers different aspects of the low-carbon energy transformation in South Asia. In their survey paper, Abdullah Fahimi (University of Lueneburg) and

Kai Stepputat (Technische Universität Berlin) address the “[Low-carbon energy transformation and sustainable development in India, Pakistan, Afghanistan, and China](#)” ([Chap. 5](#)). Combined, the four countries represent about 40% of the world’s population, over 20% of the world’s GDP, and about 40% of the world’s CO<sub>2</sub> emissions. Therefore, the status and future energy economic development of those countries has a significant impact on the implementation of the Paris Agreement. The paper provides an overview of the current economic status of the countries and identifies energy economic trends and barriers. Results show that currently, climate targets are missed. However, positive decarbonization drivers such as a potential push for renewables can be identified. This can be accompanied by further advantages such as decreasing dependency on the import of fossil fuels and additional liquidity for energy infrastructure, due to fuel cost savings. Significant policy change is required to turn around the situation and to have a chance of reaching any of the set climate goals.

[Chapter 6](#) analyses the “[Consequences of lockdown due to COVID-19 on the electricity generation and the environment in South Asia](#)”. Shameem Hasan (Ahsanullah University of Science and Technology), and Mirza Rasheduzzaman, and M. Mofazzal Hossain from the Department of Electrical and Electronic Engineering at the University of Liberal Arts in Dhaka (Bangladesh) investigate the impact of the pandemic in terms of reduction of power generation and greenhouse gas emission reductions during the lockdown period. The paper covers carbon dioxide (CO<sub>2</sub>), sulfur dioxide (SO<sub>2</sub>), nitrogen oxides (NO<sub>x</sub>), and fluorinated gases for India, Bangladesh, and Sri Lanka. All countries are heavily affected, but India shows the highest level of decline of emissions, in the range of 30%.

Another focus on India is given in [Chap. 7](#), by Neshwin Rodrigues, Raghav Pachouri, Shbbam Thakare, G. Renjit, and Thomas Spencer (TERI, New Delhi, India): “[Integrating wind and solar in the Indian power system: An assessment with a unit commitment and dispatch model](#)”. The paper explores the pathway to integrating high renewable generation by 2030, with effective balancing of supply and demand. A unit commitment and economic dispatch model simulates the power system operation in detail. The overall share of variable renewables reaches 26% and 32% in the Baseline Capacity Scenario, and the high Renewable Energy Scenario, respectively. Battery storage provides daily balancing while reducing renewable curtailment to less than 0.2% in the high renewable scenario. High renewable penetration is found possible by 2030 in India, at no extra system costs.

## 4.4 Part III: Lessons from Sub-Saharan Africa

Part III of the book includes four papers on lessons from the energy transformation in Sub-Saharan Africa. In a survey paper ([Chap. 8](#)), George Arende and Sofia Goncalves from EIT InnoEnergy (Stockholm, Sweden) analyse “[Decentralized electrification pathways in Sub-Saharan Africa](#)”. The chapter reviews the barriers to private sector participation in decentralized electrification projects, and the solutions that have been proposed. It investigates economic approaches, solutions, and drivers. Some of the specific technological pathways that have proven fruitful in Sub-Saharan Africa (SSA) are unique to its economic and demographic settings, that otherwise would not be adopted or used in the developed countries. Long-term energy planning with the integration of power pools is instrumental to reduce the capital costs, as well as to increase the market size. Blended financing, together with the already working technologies such as pay-as-you-go, and mobile money will be the pillars to meeting SDG7 goals.

In [Chap. 9](#), Charles Muchunku (energy consultant from Nairobi, Kenya) and Georg Heinemann (Microenergy Systems, TU Berlin), identify “[Effective electrification approaches and combinations thereof to meet universal electricity access targets in Eastern Africa](#)”. The chapter explores societal challenges of universal access to electricity and provides a broad understanding of how firms in the electrification industry and their environments co-evolve. Until recently there has been little coordination between governments in Eastern Africa and private firms to deliver electricity access. Private sector off-grid electrification approaches have demonstrated the potential to deliver access quickly, at scale and at a lower cost than some on-grid approaches (e. g., grid intensification and grid extension). Governments in Eastern Africa have therefore begun to develop electrification strategies that seek to combine and optimize public led on-grid approaches with private led off-grid approaches to be implemented through public-private partnership arrangements. In addition, large scale on-grid electrification programs are likely to over-extend national electricity utilities, because of the rapid increase in the number and spread of new customers resulting from grid extension and mini-grid projects. This could be mitigated by extending ownership and operation of these projects to private firms who would function as small power distributors—purchasing power in bulk from the national utility and reselling it to consumers.

Two chapters on a particularly captivating country close the book: Tanzania, where ambition on access was particularly high, but results have been mixed so far. Elias Zigah, Mamadou Barry, and Anna Creti from the Chair of Climate Economics and Paris Dauphine University ask a simple question ([Chap. 10](#)): “[Are mini-grid projects in Tanzania financially sustainable?](#)” While it is commonly

acknowledged that mini-grids are the new pathway to bridging the high electricity access deficit in SSA, comparably few studies have assessed how existing regulations and tariff policies in SSA affect their potentials to attract the number of private investments required to scale-up deployments. The participation of private investors is particularly crucial to meet the annual electrification investment gap of US-\$ 16 billion in SSA. The authors study the regulatory framework, the tariff structure, and the subsidy schemes for mini-grids in Tanzania. Additionally, using an optimization technique, they assess the profitability of a mini-grid electrification project in Tanzania from a private investment perspective. The authors find that the approved standardized small power producers' tariffs and subsidy scheme in Tanzania still do not allow mini-grid for rural electrification projects to be profitable. Further research is required to identify successful business models and strategies to improve mini-grids' profitability.

Last but certainly not least, Guglielmo Mazzà from Microfinanza Srl and colleagues address a similar topic in [Chap. 11: “Establishing local power markets and enabling financial access to solar and photovoltaic technologies: experiences in rural Tanzania”](#). The introduction of new technological products requires to establish local power markets, including demand, financial resources and providers, supply mechanisms and after-sale services. The financing of renewable energy solutions for rural households partially relies on microfinance institutions and community financial groups. Technology suppliers also provide financial services to expand access to solar and photovoltaic products, applying models mostly enabled by mobile payment systems. The paper assesses the effects of an initiative implemented in Malinyi and Kilombero districts to support the establishment of local solar power markets. The involvement of Village Community Banks to engage communities and develop sustainable financial schemes is evaluated, together with the complexity of combining awareness raising on technological solutions and financial education. Results of the implementation are presented and discussed evaluating different ingredients of the established markets.

## 5 Concluding Remarks

The conference, and consequently also this book have taken a Global South micro perspective on the energy transformation that the world is currently undergoing. Transformations are hard. Hence, often we tend to draw on a transition mode, many times irrespective of the urgency that required us to change in the first place. The inertia is usually based on legacy infrastructure, and vested interests of incumbents. What makes this book so interesting is that throughout its contribu-

tions it takes a perspective from places where often relatively little legacy infrastructures are in place and vested interests from incumbents are felt “less” due to a bottom-up approach.

However, it would be easy to reason now that this is a perfect combination for leapfrogging, where a (technology) breakthrough is reached by skipping intermediate steps (e. g., the fact that many people in the Global South have never seen a landline, but went straight to the mobile phone, and possibly have picked up this technology much faster than a comparative group in the Global North, which had stronger inertia due to the existence of landlines). Can we infer from here that the Global South will abandon fossil fuels much quicker, and skip building large grid infrastructures with centralized production of electricity in places where it is not needed? And will it directly go to a distributed and decarbonized infrastructure? The answer is a yes and no. “Yes”, in the sense that we see several contributions made where this is happening, especially when it comes to rural electrification, but “no”, we also see, especially in the context of Bangladesh, that complexities emerge when both approaches are being undertaken at the same time. An attempt to mimic the known centralized grid electrification, based largely on fossil fuels, is complemented by a model that fully embraces the 4 Ds with the world’s largest distributed solar electrification program.

It remains to be seen in how far microgrids will take up an increasing role in both the Global North and South. Maybe the question is not if but rather when, and how much time has been lost in transition mode in the interim.

**Acknowledgements** An undertaking like this book is necessarily a collective task, and there are many individuals and organizations involved in it. BRAC University and Technische Universität Berlin (TU Berlin), both represented at the conference by their respective presidents, have shouldered most of the organizational effort. We acknowledge support by the Open Access Publication Fund of Technische Universität Berlin.

Thanks go to the representatives of the Bangladesh Power Division from the Sustainable and Renewable Energy Development Authority (SREDA), from Power Cell and the Bangladesh Rural Electrification Board (BREB), as well as to the Infrastructure Development Company Limited (IDCOL) for their special contributions to dedicated conference sessions. Thanks further go to Prof. Vincent Chang (President of Brac University), Prof. Eileen Peacock (Dean of the Graduate School of Management, Brac University), Prof. Valerie Karplus (Assoc. Prof, Engineering and Public Policy, Carnegie Mellon University), the team at ME SOLshare in Dhaka (Bangladesh), and Xenia Ritzkowsky, and Jens Weibezahn in Berlin (Germany). Fabienne Banzer coordinated the preparation of the manuscript. Special acknowledgements go to Microenergy Systems, mainly Noara Kebir, and Daniel Phillip, for bringing together, once again, many diverse researchers and policy analysts, in a longer-term effort to advance the knowledge and practice about bottom-up small-scale electrification. Let’s keep on swarming!



## 6 Appendix: A selection of panelists' quotes at the MES2021 Conference

Participants, speakers and invited guests celebrated the MES2021 conference, a fully packed 3-day journey with diverse contributions and fruitful discussion. Hereafter a selection of quotes from notable speakers and discussants is shared, in no particular order and paraphrased at times:

*We need to change our thinking going from energy access to energy well-being, the session should not be called Universal Basic Energy Supply, but Universal Basic Energy Services.*

- Shonali Pachauri, IIASA during the Universal Basic Energy Services Session.

*MES or Microenergy Systems as I understand it, very interestingly, is in fact the missing piece from my own PhD, many, many years ago.*

- Vincent Chang, President, BRAC University during his opening keynote.

*I am impressed by Bangladesh's progress on decentralized energy systems, and during a visit last year by Prof. von Hirschhausen we found very good potential for academic collaboration.*

- Christian Thomsen, President, TU Berlin, during his opening keynote.

*How do we avoid a climate disaster? Because all our economic growth has little value if it is just washed away in an instant.*

- Sebastian Groh, Brac Business School, during his Opening Panel moderation.

*After 100% electrification we need to focus on how we get from quantity to quality.*

- Amzad Hossain, Member, Bangladesh Renewable Energy Board during the Contributory Microgrid Session.

*Only with decentralized storage, a grid can be resilient. Any country must be strong on storage manufacturing & recycling to be prepared for the energy future.*

- Hannes Kirchhoff, SOLshare during the Contributory Microgrid Session.

*The grid is a social good, w/o it there is a route to inequality! We need to leverage the grid together with distributed models.*

- Chris Wright, Moixa during the Contributory Microgrid Session.

*Bangladesh's Prime Minister has committed to 100% RE by 2050—but the country lacks a clear roadmap towards it, let alone a conducive policy.*

- Munawar Moin, Solar Module Manufacturers Association of Bangladesh, during the 100% Electrification—What Comes Next for Bangladesh? Session.

*The focus needs to go toward energy for productive use, e. g., transport, there are 4M e-rickshaws alone in India and Bangladesh –we need to build a renewable-powered charging platform for them.*

- Eshrat Waris, SOLshare during the 100% Electrification, and the e-mobility session, respectively.

*Why is it so difficult for developing countries to introduce subsidies toward more decentralized storage?*

- Julio Eisman Valdés, ACCIONA Microenergia Foundation

*Despite best efforts, the availability and affordability of DC appliances is not in place, and we had to tweak our system to accommodate AC appliances.*

- Nithia Menon, Okra Solar/ Daniel Ciganovic, SOLshare in the Microgrid-ders session.

*We need to make our national grid smarter.*

- Muhammad Hossain, Director General, Power Cell, Bangladesh during the Contributory Microgrid Session.

*We need to develop policies to incentivize feed-in from distributed generation and storage, e. g., through community power purchasing agreements.*

- Raluca Dumitrescu, TU Berlin, during the research session on Market Design & Tariffication.

*Bangladesh is embarking on a new journey after the confirmation a few days back of its graduation from the least developed countries. This is a massive success for the country coinciding with its 50 years celebration of independence. On this new journey, we should reduce our dependency on fossil fuels and raise our share in renewables. For this to happen, we need more innovation in business models, technology such as distributed storage and generation as well as policy reform.*

- Mohammad Alauddin, Chairman, SREDA during the Contributory Micro-grid Session.

*Don't say we have no biomass, we have no wind, we have no land for solar PV—YOU HAVE! Even though your situation is clearly different. When I was a German State Minister for Agriculture and Environment 20 years ago, I heard the same things, but we need to jointly overcome the fossil fuel lobbies.*

– Baerbel Hoehn, Global Renewables Congress, during the Powering-up a country into the middle-income club session.

*There is USD 1 billion in subsidies for oil & gas per year, while there is no clear subsidy policy for renewables in place to date.*

– Mohammad Tamim, BUET, via the chat in Powering-up a country into the middle-income club session.

*“If you understand something in only one way, then you don't really understand it at all”, Marvin Minsky, the co-founder of MIT's Artificial Intelligence Laboratory*

– quoted by Nancy Wimmer, Microsolar.

*The bottom line is, the GoB has committed to 100% electrification of some form by 2021 and it has followed through, but one of the weaknesses of the strategy has been that generation capacity was increased too massively—we are paying for a lot of idle capacity—the burden falls on the consumers or the Bangladeshi citizens. You can make any power project viable if you make the PPA high enough, incl. capacity payments, that's the role of the regulator where a better job needs to be done.*

– Ahsan Mansur, Policy Research Institute of Bangladesh, in the Powering-up a country into the middle-income club session.

*The energy pricing policy needs to be tackled, this is a jungle, the time has really come to sort this out. Unless we get the pricing right, we will not have the optimal technical or social mix. On renewables, we need to make a move, everybody around us is doing it, even if we must do this with subsidies, we need to explore this much more thoroughly.*

– K.A.S. Murshid, Bangladesh Institute of Development Studies, in the Powering-up a country into the middle-income club session.

*Most of the VCs are run by men, no wonder that less than 3% of women-led business get access to VC funding. Interestingly, women-led businesses are also not asked the same questions during the DD compared to men-led businesses,*

*more emphasis is put on risk than on growth potential—this is a skewed process as growth focused DD processes get 7x more funding.*

- Cécile Dahome, Sevea, during the Empowering Women through Renewable Energy Entrepreneurship session.

*If we talk about rural female entrepreneurship, we need to talk market link-ages.*

- Aziza Sultana Mukti, SOLshare, during the Empowering Women through Renewable Energy Entrepreneurship session.

*PAYG companies in Sub-Saharan Africa are nowhere close to what has been done in Bangladesh but in 99% of off-grid conferences it is not being talked about—why?—there is no domestic local currency financing, no local manufacturing industry. Businesses in Bangladesh must ask themselves the question why we didn't venture out into those markets.*

- Sanjoy Sanyal, Regain Paradise, during 100% Electrification—What Comes Next for Bangladesh?

*We need to investigate e-rickshaws, and we will, we must look also into the larger transport sector from the perspective of green energy and sustainable urban development.*

- Angelika Fleddermann, GIZ BD, during the Outlook session.

*At SE4ALL we look at the hot and the cold side of SDG 7, the hot side is access to clean cooking which has no silver bullet but it's a huge need. The cold side is the entire aspect of cooling and cold chains which gained prominence recently triggered by the diverse cooling requirement of the COVID-19 vaccines.*

- Hadley Taylor, SE4ALL.

*The hardest part of every single project is not the design, nor the tech in general, it is the institutions, the permits, the politics of will, we spend 10times more on political logistics than on anything else. The stronger the community sense for a project is, the easier to push all this heavyweight uphill—we need more sociologists & psychologists.*

- Daniel Kammen, UC Berkeley during a Q&A session with Bernd Moeller, Europa Universitaet Flensburg.

*MES—Microenergy Systems was born in Bangladesh as the microenergy project, micro is the small part, and the beauty was what we had found in Bangladesh back in 2002 in the solar home system program but also why small here is so powerful.*

– Daniel Philipp, MicroEnergy International, during the Small is beautiful session.

*A lot of the psyche of the university comes from empathy, comes from solving the problems of the masses in the spirit of its founder Sir Fazle Abed—this has taken the university forward!*

– Sonia Bashir Kabir, Board of Trustees at Brac University during the Outlook Session.

## References

- Blechinger, P., Köhler, M., Berendes, S., & Nettersheim, C. (2019). “Off-Grid Renewable Energy for Climate Action—Pathways for Change.” *Deutsche Gesellschaft für Internationale Zusammenarbeit (GIZ)*. <http://www.reog-x.com/>.
- Bogdanov, D., Gulagi, A., Fasihi, M., & Breyer, C. (2021). “Full energy sector transition towards 100% renewable energy supply: Integrating power, heat, transport and industry sectors including desalination.” *Applied Energy*, 283(February), 116273. <https://doi.org/10.1016/j.apenergy.2020.116273>
- Ferrall, I., Heinemann, G., von Hirschhausen, C., & Kammen, D. M. (2021). “The role of political economy in energy access: Public and private off-grid electrification in Tanzania.” *Energies*, 14(11), 3173. <https://doi.org/10.3390/en14113173>
- Groh, S., Pachauri, S., & Rao, N. D. (2016). “What are we measuring? An empirical analysis of household electricity access metrics in rural Bangladesh.” *Energy for Sustainable Development*, 30(February), 21–31. <https://doi.org/10.1016/j.esd.2015.10.007>
- Heinemann, G., Banzer, F., Dumitrescu, R., von Hirschhausen, C., Neuhof, M., & Nwadiaru, V. O. (2020). “Transforming Electricity Access by Replacing Back-up Generators with Solar Systems? Recent Trends and Evidence from Nigeria.” Presented at the EAERE Policy Session “Electrification,” June 25.
- von Hirschhausen, C., Ansari, D., Banzer, F., Dumitrescu, R., Heinemann, G., & Kemfert, C. (2020). “Stromzugang Im Globalen Süden: Dezentrale Erneuerbare Energiesysteme Bieten Echte Alternative.” *DIW Berlin Wochenbericht*, (48), 891–899. [https://doi.org/10.18723/DIW\\_WB:2020-48-3](https://doi.org/10.18723/DIW_WB:2020-48-3).
- von Hirschhausen, C., Gerbaulet, C., Kemfert, C., Lorenz, C., & Oei, P.-Y. (eds.). (2018). *Energiewende “Made in Germany”: Low Carbon Electricity Sector Reform in the European Context*. Springer Nature Switzerland AG.
- IEA. (2017). *World Energy Outlook 2017*. OECD. <https://doi.org/10.1787/weo-2017-en>.

- IEA. (2020). *World Energy Outlook—2020*. OECD. <https://www.iea.org/reports/world-energy-outlook-2020>.
- IEA, IRENA, United Nations, World Bank, & WHO. (2021). “Tracking SDG7: The Energy Progress Report.” The World Bank. <https://www.irena.org/publications/2021/Jun/Tracking-SDG-7-2021>.
- IEA, UNDP, & IRENA. (2018). “Policy Brief 01—Achieving Universal Access to Electricity.” Accelerating SDG 7 Achievement. United Nations. <https://sustainabledevelopment.un.org/content/documents/17462PB1.pdf>.
- IRENA. (2021). “Renewable Power Generation Costs in 2020.” International Renewable Energy Agency. <https://www.irena.org/publications/2021/Jun/Renewable-Power-Costs-in-2020>.
- Karplus, V. J., & von Hirschhausen, C. (2019). “Electricity Access: An Introduction.” *Economics of Energy & Environmental Policy*, 8(1). <https://doi.org/10.5547/2160-5890.8.1.vkar>.
- Krause, F., Bossel, H., & Müller-Reissmann, K.-F. (1980). *Energie-Wende: Wachstum und Wohlstand ohne Erdöl und Uran*. Edited by Öko-Institut Freiburg. S. Fischer.
- Lovins, A. B. (1976). “Energy strategy: The road not taken?” *Foreign Affairs*, 6(20), 9–19.
- Lovins, A. B. (1979). *Soft Energy Paths: Towards a Durable Peace*. New York: Harper & Row. <http://www.environmentandsociety.org/mml/soft-energy-paths-towards-durable-peace>.
- Oei, P.-Y., Burandt, T., Hainsch, K., Löffler, K., & Kemfert, C. (2020). “Lessons from Modeling 100% Renewable Scenarios Using GENeSYS-MOD.” *Economics of Energy & Environmental Policy*, 9(1).
- Papafthymiou, G., & Dragoon, K. (2016). “Towards 100% renewable energy systems: uncapping power system flexibility.” *Energy Policy*, 92(May), 69–82. <https://doi.org/10.1016/j.enpol.2016.01.025>
- Pelz, S., Brutschin, E., & Pachauri, S. (2022). “Conceptual and Institutional Prerequisites for Guiding Equitable Progress Towards Universal Rural Electrification.” *Economics of Energy & Environmental Policy*, 11(1). <https://doi.org/10.5547/2160-5890.11.1.spel>.
- Puig, D., Moner-Girona, M., Kammen, D. M., Mulugetta, Y., Marzouk, A., Jarrett, M., Hailu, Y., Nakićenović, N. (2021). “An Action Agenda for Africa’s Electricity Sector.” *Science*, 373(6555), 616–619. <https://doi.org/10.1126/science.abh1975>.
- United Nations. (2015). “Transforming Our World: The 2030 Agenda for Sustainable Development.” *Draft resolution referred to the United Nations summit for the adoption of the post—2015 development agenda by the General Assembly at its sixty—ninth session*. United Nations.
- WBGU. (2011). *World in Transition: A Social Contract for Sustainability—Flagship Report*. German Advisory Council on Global Change (WBGU). [http://www.wbgu.de/fileadmin/templates/dateien/veroeffentlichungen/hauptgutachten/jg2011/wbgu\\_jg2011\\_en.pdf](http://www.wbgu.de/fileadmin/templates/dateien/veroeffentlichungen/hauptgutachten/jg2011/wbgu_jg2011_en.pdf).
- Wimmer, N. (2012). *Green Energy for a Billion Poor: How Grameen Shakti Created a Winning Model for Social Business*. MCRE-Verl.
- Wimmer, N. (2019). *The Marketmakers: Solar for the Hinterland of Bangladesh*. MCRE Publishing.

World Bank, SE4ALL database. (2020a). “Access to Electricity (% of Population)—Selected Regions.” <https://data.worldbank.org/indicator/EG.ELC.ACCS.ZS?locations=KE>. Accessed: 3. Nov. 2020.

World Bank, SE4ALL database. (2020b). “Access to Electricity (% of Population)—Global.” <https://databank.worldbank.org/reports.aspx?source=2&series=EG.ELC.ACCS.ZS&country=>. Accessed: 4. Nov. 2020.

**Open Access** This chapter is licensed under the terms of the Creative Commons Attribution 4.0 International License (<http://creativecommons.org/licenses/by/4.0/>), which permits use, sharing, adaptation, distribution and reproduction in any medium or format, as long as you give appropriate credit to the original author(s) and the source, provide a link to the Creative Commons license and indicate if changes were made.

The images or other third party material in this chapter are included in the chapter's Creative Commons license, unless indicated otherwise in a credit line to the material. If material is not included in the chapter's Creative Commons license and your intended use is not permitted by statutory regulation or exceeds the permitted use, you will need to obtain permission directly from the copyright holder.





# Powering up a Country into the Middle-Income Club

## The Story of Bangladesh

Sakib Amin, Ahsan H. Mansur, Syed Mafiz Kamal  
and Sebastian Groh

### Abstract

In this paper, we discuss the stylized facts of Bangladesh's energy sector, critically review the different policies of the government for powering up the nation in the last 50 years, identify existing controversies and finally indicate potential pathways to ensure future energy security. The novelty of the papers is twofold: First, prior literature did not study the in-depth policy analysis of the Bangladesh energy sector. Second, this paper contributes to the existing literature by providing strategic policy suggestions to the Bangladesh government for formulating its own set of energy policies to achieve its vision for 2041 of becoming a high-income country, after having cleared the interim goal

---

S. Amin (✉)

School of Business and Economics, North South University, Dhaka, Bangladesh

e-mail: [sakib.amin@northsouth.edu](mailto:sakib.amin@northsouth.edu)

A. H. Mansur

Policy Research Institute, Dhaka, Bangladesh

S. M. Kamal

Centre for Research and Information, Dhaka, Bangladesh

S. Groh

Brac Business School (BBS), BRAC University, Dhaka, Bangladesh

e-mail: [sebastian.groh@bracu.ac.bd](mailto:sebastian.groh@bracu.ac.bd)

© The Author(s) 2023

S. Groh et al. (eds.), *Electricity Access, Decarbonization, and Integration of Renewables*, Energiepolitik und Klimaschutz. Energy Policy and Climate Protection, [https://doi.org/10.1007/978-3-658-38215-5\\_2](https://doi.org/10.1007/978-3-658-38215-5_2)



of becoming a middle-income country at its 50th anniversary of independence. The paper also provides insights for other developing countries aspiring to become middle-income countries.

---

**Keywords**

Bangladesh · Energy Security Pathways · Energy Policy · Policy Analysis

---

## 1 Introduction

The supply of reliable and affordable energy has become imperative in most production and household activities in modern society. In their seminal work, Goldemberg et al. (1985) discuss that the role of energy in the development process is undeniable as access to energy is a precondition for meeting basic human needs. Amin et al. (2020) argue that no country has accomplished significant progress beyond a subsistence level without guaranteeing a certain energy level. Furthermore, energy influences economic activities, workers' productivity and is a major constituent for improving the quality of life, especially in developing and emerging countries (Rehman et al., 2019). Existing empirical and theoretical literature also finds support for the "growth hypothesis" across the globe.<sup>1</sup> Therefore, having a good strategic framework and security for energy resource management is considered a compulsory element for planning long-run sustainable development.

Located in the northeastern region of South Asia, Bangladesh earned its independence in 1971. The country's origins lay in a deprived and undiversified economy with a pre-existing agricultural economy with low productivity, a weak industrial sector, and poor infrastructure. However, despite the adversities and resource constraints, Bangladesh's economy has experienced landmark successes over the past five decades, as reflected in different socio-economic indicators in Table 1. On average, the GDP growth of Bangladesh has increased from approximately three percent in the 1970s to seven percent in the 2010s and has traversed eight percent prior to the Covid-19 pandemic disruption. According to the Bangladesh Bureau of Statistics (BBS, 2018), extreme poverty was reduced to 10.50% in 2019 from approximately 80% in the early 1970s. Importantly, the Government's goals of a "Sonar Bangla" (Golden Bangladesh) includes its commitment to a low-carbon development path (Momen, 2021).

---

<sup>1</sup>Growth hypothesis implies that energy consumption speeds up economic activities, for more details, see: Amin et al. (2021b).

**Table 1** An overview of socio-economic indicators in Bangladesh. (Source: World Development Indicators (2020))

Criteria	1972	1980	1990	2000	2009	2019
GNI/Capita (Constant USD 2010)	329.74	360.46	421.15	542.55	803.30	1348.26
Primary School Enrolment (Percent of Gross) *	64.52	71.61	83.80	101.65	102.93	116.50
Child Mortality (Under 5)	221.10	198.61	143.80	86.50	51.50	30.80
Fertility Rate (Births Per Woman)	6.93	6.36	4.50	3.17	2.38	2.03
Life Expectancy (Years)	46.51	52.90	58.21	65.45	69.49	72.32

*Note: Gross enrolment may surpass 100 because of inclusion of over-aged and under-aged students due to early or late school entrance and grade repetition*

Groh (2014), and Samad and Zhang (2018) argue that the successful implementation of the Solar Home System (SHS) program in Bangladesh has played a crucial part in reducing energy poverty and increasing people's development opportunities. Khatun (2021) states that life expectancy has increased more than 1.5 times compared to 1972 levels, and GNI/capita has quadrupled in the same timeframe.<sup>2</sup> The Covid-19 pandemic has unexpectedly placed the country in a bad economic downfall. Ahmed and Kamal (2020) argue that the Covid-19-triggered loss on the GDP can worsen the unemployment condition largely, with six million new people becoming jobless.<sup>3</sup> Amin et al. (2021a) simulated a dynamic model and revealed that the economic growth rate in Bangladesh would be approximately 4.5% in the long run, faster than many other countries. This growth prediction is consistent with the International Monetary Fund (IMF) forecast and lies between the Bangladesh Government and the World Bank (Fig. 1).<sup>4</sup>

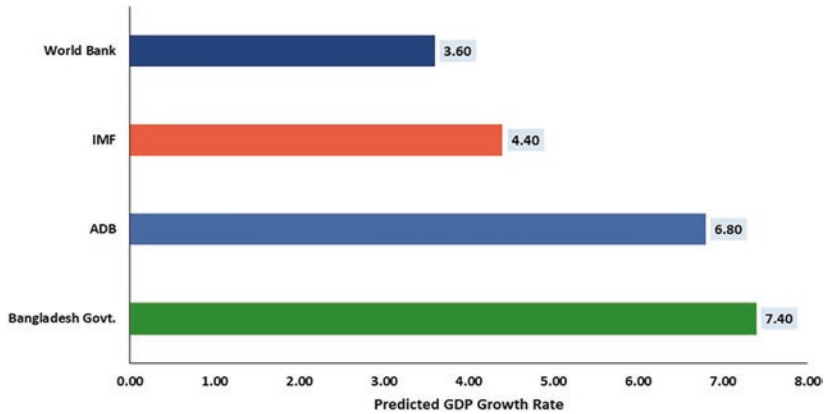
In 2021, the United Nations Committee for Development Policy (CDP) approved the graduation of Bangladesh from the list of Least Developed Countries (LDC) as it satisfied the eligibility standards with regard to per capita income, human resources, and economic and environmental vulnerability for the second time in a row since 2018.<sup>5</sup> With an aspiration to become a high-income country

<sup>2</sup>For more details, see: <https://cpd.org.bd/bangladeshs-achievements-in-50-years-and-making-it-meaningful/>

<sup>3</sup>[https://cri.org.bd/files/Bangladesh\\_at\\_work\\_in\\_the\\_era\\_of\\_COVID-19.pdf](https://cri.org.bd/files/Bangladesh_at_work_in_the_era_of_COVID-19.pdf).

<sup>4</sup>For more details, see: <https://www.tbsnews.net/economy/world-bank-keeps-bangladeshs-growth-forecast-unchanged-16-181846>.

<sup>5</sup>For more details, see: <https://www.thedailystar.net/business/news/bangladesh-gets-un-recommendation-graduating-ldc-status-2051857>.



**Fig. 1** Economic growth projection in Bangladesh in 2021. (Source: The business standard (2021))

by 2041 and reduce extreme poverty by 2030, Bangladesh currently focuses on achieving sustained economic growth by generating more employment, enhancing the standard of health and education, energy and transport infrastructure, and governance, together with reinforcing anti-corruption procedures (GED, 2020). Accordingly, the energy industry is recognized and prioritized as an important element of sustainable development for the future of the Bangladesh economy.

However, during the liberation war of 1971, the country's infrastructure was largely destroyed. Bangabandhu Sheikh Mujibur Rahman, also coined as the father of the nation, had to take on the Sisyphean task of statecraft and building a nation from scratch.<sup>6</sup> Sobhan (2021) argues that it was challenging for the then Awami League government to address reconstruction problems while dealing with the political bottlenecks associated with institutions, constructing economic policies, and managing their implementation. However, Bangabandhu's resolute leadership placed Bangladesh on the right track of development with a top priority placed on a reconstruction and large-scale recovery program between 1972–1975.

Among other sectors, the power and energy sector of the country was also systematically destroyed. Therefore, 'powering up the nation' has been among the

<sup>6</sup>For more details, see: <https://cri.org.bd/publication/Mujib/A-Nation-Rises.pdf>.

top priorities of the Bangladesh government since its independence. Having realized the significance of the energy and power sector as the lifeblood for industrial and economic development in 1971, Bangladesh took multiple strides towards the development of the energy sector by restoring transmission and distribution lines, repairing the power stations and bridges, harnessing the country's mineral resources and beginning the extraction, distillation, and marketing of mineral oil and natural gas.<sup>7</sup> Bangabandhu established the Bangladesh Petroleum Exploration and Production Company Limited (BAPEX) and Bangladesh Power Development Board (BPDB) for the country's future energy security. He bought five gas fields from Shell Oil Company at a low rate of USD 13–14 million to obtain Bakhrabad, Titas, Rashidpur, Kailashtila, and Habiganj gas fields as state-owned gas fields. Today, approximately 31.44% of the country's total gas is produced from these fields.

Since 2009, the present Awami League government has been working to develop multiple sectors in the country, including the energy sector. When the Awami League government came into power in 2009, the country went through two significant problems: Firstly, the electricity demand exceeded its supply between 2000 to 2009. Secondly, the nation relied too much on natural gas, which was the source for more than 90% of the electricity (Amin et al., 2021a). The energy crisis in the early 2000s had become severe due to the immense gap between energy demand and supply. The gap emerged primarily due to Bangladesh's transformation from an agrarian to an industry-based economy in the late 1990s. Such change in the concentration of economic activities required more energy use, but unfortunately, the supply of energy commodities was staggering, resulting in a chronic energy crisis. World Bank (2018) argues that energy and infrastructure bottlenecks remained the main impediments to economic growth for an extended period, and hence the then government put topmost priority on reforming the energy sector.

Amin (2015) and Amin et al. (2021b) argue that the main reform programs during the last 50 years include: i) restructuring of the core utilities, ii) establishing the independent regularity authorities, iii) encouraging the private firms (Independent Power Producers, IPPs; Captive Power Producers, CPPs) to enter

---

<sup>7</sup>For more details, see: <https://www.thedailystar.net/country/news/national-energy-security-day-bangabandhu-the-pathfinder-national-prosperity-1942153>.

the energy market,<sup>8, 9</sup> iv) allowing the privately owned rental and Quick Rental Power Plants (QRPP) as a quick and short term solution to reduce the then persistent electricity crisis, v) strengthening the fuel diversification in the electricity generation mix, vi) revising the energy prices to ensure cost-reflective pricing, vii) promoting the uses of renewable energy and viii) improving energy efficiency.

Moreover, the Bangladesh government formulated extensive energy and power development plans, the Power System Master Plan (PSMP) in 2005, 2010, and 2016, the National Energy Policy (NEP) of 2008 to achieve the sustainable development goals in harmony with economical optimization. These master plans focused on short, medium, and long-term power generation plans to develop a sound power generation environment that maximizes the advantages of different power generation methods, including the broad outlook of stable power supply, energy reliability and efficiency, environmental sustainability, and economic stability.<sup>10</sup>

These initiatives resulted in remarkable success in the Bangladesh energy sector in the last few years, especially in raising the electricity generation capacity.<sup>11</sup> However, despite this success, there are a few controversies regarding the skewness towards fossil fuels in the energy mix which still remains very high<sup>12</sup>, quality of power issues, nonchalance in harnessing the potentials of renewable energies, lack of private investment in power transmission and distribution, high energy subsidies, an absence of a competitive market environment, as well as ‘collusive contracting in an on-going state of emergency’ (Khan et al., 2020) etc. Moreover, while the sector incurs massive financial losses on the government side, the share of idle generation capacity has been exceedingly high over the last

---

<sup>8</sup>For more details, see: [https://www.bpdb.gov.bd/bpdb\\_new/d3pbs\\_uploads/files/11%20March%2019/1.%20PSEGPB.pdf](https://www.bpdb.gov.bd/bpdb_new/d3pbs_uploads/files/11%20March%2019/1.%20PSEGPB.pdf).

<sup>9</sup>For more details, see: THIS LOOKS A LITTLE ODD [https://berc.portal.gov.bd/sites/default/files/files/berc.portal.gov.bd/policies/37a75205\\_8c94\\_434e\\_b8e8\\_0dd643b2a00d/Policy%20Guidelines%20for%20Power%20Purchase%20from%20Captive%20Power%20Plant,%202007.pdf](https://berc.portal.gov.bd/sites/default/files/files/berc.portal.gov.bd/policies/37a75205_8c94_434e_b8e8_0dd643b2a00d/Policy%20Guidelines%20for%20Power%20Purchase%20from%20Captive%20Power%20Plant,%202007.pdf).

<sup>10</sup>The policies incorporated in the perspective plan 2021 and 2041 are also aligned and consistent with the mainstream energy policies and lay the foundations for the considerable success.

<sup>11</sup>For Instance, power generation grows at an average annual pace of 13.4% per year between 2010 and 2019, when generation capacity quadrupled from about 5000 MW to over 22,000 MW.

<sup>12</sup>According to the recent statistics from SREDA (2020b), only 633.31 MW of electricity is produced from renewable sources, where solar energy plays a significant contributor (63.06%).

couple of years and further worsened due to the impact of Covid-19 (> 60%). Experts argue that the dependency on the imported fuel will further expose the country to many macroeconomic issues such as oil price shocks, LNG price fluctuations, and welfare loss (Maheu et al., 2020).

Furthermore, in Bangladesh, the per capita energy consumption remained low at 320 kilowatt-hours (kWh) in 2014 compared to the South Asian average (705 kWh), as found in the latest available data from the World Bank.<sup>13</sup> However, Steckel et al. (2013) shed light on the requirement of reaching a threshold level of per capita energy consumption that corresponds to a high development priority as defined by the United Nations Human Development Program, and to avoid the threat of being trapped in an energy poverty penalty that inhibits economic development (Groh, 2015). Once this threshold is crossed, the historically observed strong positive correlation between energy use and economic growth might break, making way for a low-carbon development path.

The rest of the paper is organized in the following way: Section 2 provides a survey of the last five decades of energy sector development. Section 3 highlights the stylized facts of the Bangladesh energy sector, followed by a brief discussion on market reforms in Bangladesh's energy sector in Sect. 4. Section 5 provides an overview of the existing controversies surrounding the energy sector. Finally, Sect. 6 concludes the paper.

---

## **2 Stylized facts on the Bangladesh Energy Sector during Last 50 Years**

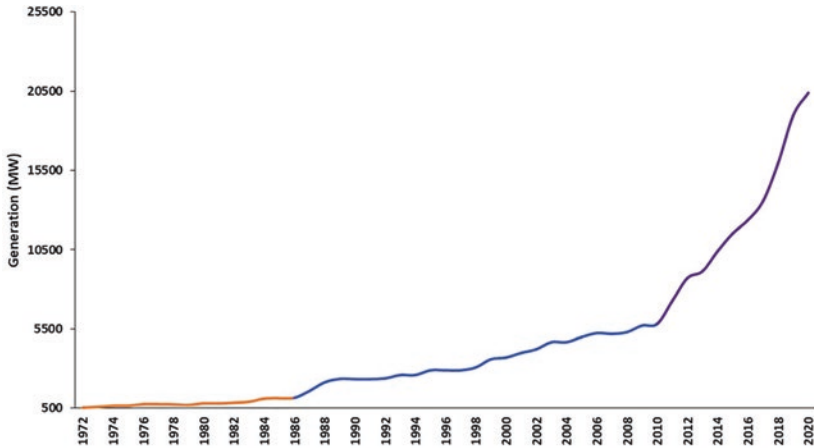
This section discusses a few of the stylized facts of the Bangladesh energy sector associated with the series of reform initiatives implemented by the Bangladesh government to ensure a sound energy base for sustainable development over the last 50 years.

### **2.1 Generation Capacity**

The generation capacity was minimal in Bangladesh during the 1970s where the average generation capacity stood at 685 Mega-watt (MW). This poor trend in the

---

<sup>13</sup>For more details, see: <https://data.worldbank.org/indicator/EG.USE.ELEC.KH.PC?locations=BD>.



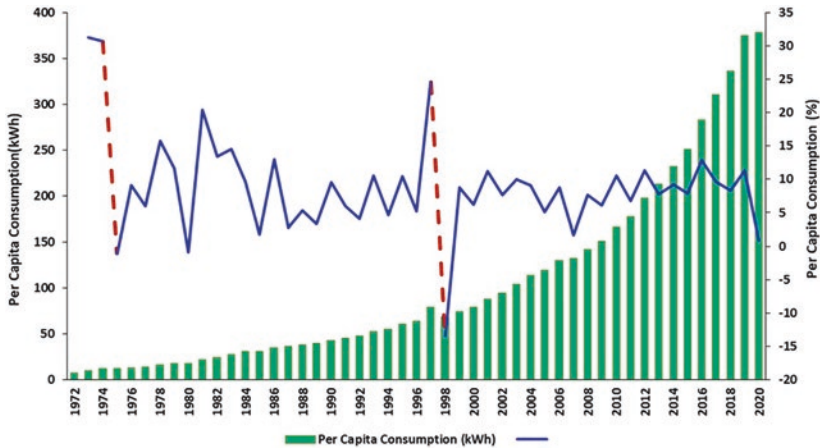
**Fig. 2** Electricity generation capacity between 1972–2020. (Source: BPDB annual report (2020))

generation capacity continued until 2009. Mujeri et al. (2013) and Tamim et al. (2013) constitute the poor conditions of generation equipment, a low number of power plants, technical limitations, and inadequate operational, organizational, and maintenance routine as the reasons behind the trend. However, Bangladesh has successfully overcome the shortfall between demand and supply of electricity by increasing its generation capacity significantly since 2009, as reflected in Fig. 2.

## 2.2 Per Capita Energy Consumption (PCEC)

Existing literature highlights that sustained economic growth results in industrialization, urbanization, increased use of technology and innovative appliances by the households, leading to increasing PCEC (Amin & Khan, 2020; Pachauri, 2012).<sup>14</sup> Murshid (2020) further argues that growing urbanization and

<sup>14</sup>Amin and Rahman (2019) argue that, “Bangladesh has experienced development mainly through industrialization, and to walk side by side with the rapid urbanization, the energy demand is expected to increase. Buildings are responsible for approximately 40% of total energy demand in urban regions. Most of this energy is for the provision of lighting, heating, cooling, and water supply”.



**Fig. 3** Per capita energy consumption between 1972–2020. (Source: BPDB annual report (2020))

industrialization encourage rural non-farm activities, especially in areas well connected to major urban centers, leading the PCEC to increase.<sup>15</sup> Figure 3 shows that PCEC has increased gradually between 1972 to 2020 with a growth rate of 8.9%. The average PCEC was only 12.60 kWh in the 1970s, 30 kWh in the 1980s and 378 kWh in 2020. The PCEC increased drastically from the 1990s due to the sectoral shift in the Bangladesh economy.

### 2.3 Access to Electricity and System Loss

Bangladesh has achieved landmark progress in ensuring access to energy to its citizens. Prior to the 1990s, the average rate of access to electricity was less than 15%, and during the 1990s, only 20% of the population had access to electricity.<sup>16</sup> Between 2000 and 2010, the average share of the population with access to electricity doubled, reaching 45%. Access to electricity became a reality for the

<sup>15</sup>For more details, see: <https://whiteboardmagazine.com/1962/insights-into-the-rural-non-farm-sector-of-bangladesh/>

<sup>16</sup>Only 3% of the population had access to electricity in 1971.



broader population due to the strategic time-variant policies of the present government which was initiated since 2009.<sup>17</sup> Bangladesh has now achieved nearly 100% electrification by providing electricity access under grid-covered areas.<sup>18</sup>

While this is a remarkable achievement, an integrated electrification pathway where a more inclusive planning approach is pursued to avoid that multiple electrification infrastructures sit on top of each other, might have resulted in a more cost-effective and inclusive universal electrification process (SE4ALL, 2019; Groh, 2015). Bangladesh is referred to as having developed the world's largest decentralized electrification program, mainly through the deployment of up to six million SHS throughout the country (Khan, 2021). The country might have avoided an energy poverty penalty due to the successful SHS program, enabling a more inclusive growth (Groh, 2014; Samad & Zhang, 2018). Moreover, Groh et al. (2016) have shown that those SHS, on average, have performed better in terms of electricity service quality than the national grid if measured against the multi-tier framework to measuring energy access quality as introduced by the World Bank's Energy Management Assistance Program (Bhatia & Angelou, 2015). Even though the number of SHS' has been declining in recent years with the rapid extension of the national grid across Bangladesh, the SHS have served an important interim socio-economic purpose by providing electricity to households in limited quantity. It is still open in how far these assets can be further leveraged as a decentralized asset to the people who own them and the regional grids they could be collectively integrated with.

Bangladesh has also been successful in reducing the system loss to a large extent. Due to heavy system loss, economic and household activities suffered from prolonged load shedding in the 1990s and early 2000s. However, the situation started to improve gradually due to technological improvement and timely policy interventions since 2009. According to the 2020 annual report of BPDB, the system loss was more than 35% in 1992, which was reduced down to 8.73% in 2020.

---

<sup>17</sup>To know more about the Bangladesh power sector, see: THIS LOOKS A LITTLE ODD [https://powerdivision.portal.gov.bd/sites/default/files/files/powerdivision.portal.gov.bd/page/710d7745\\_8a49\\_4466\\_8d4f\\_22e0a9232a73/PD%20REMARKABLE%20ACHIEVEMENT%20OF%202019-2020%20%281%29.pdf](https://powerdivision.portal.gov.bd/sites/default/files/files/powerdivision.portal.gov.bd/page/710d7745_8a49_4466_8d4f_22e0a9232a73/PD%20REMARKABLE%20ACHIEVEMENT%20OF%202019-2020%20%281%29.pdf).

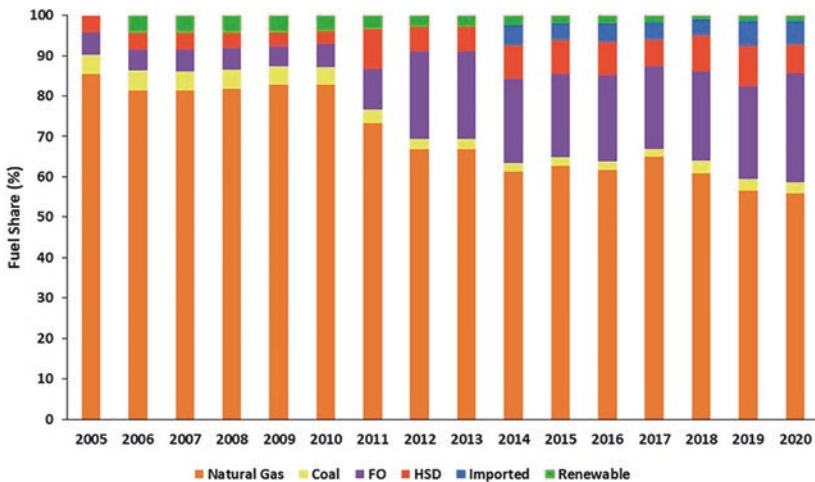
<sup>18</sup>As of May 2021, 99% of the Bangladeshi people have access to electricity. For more details, see: <https://powerdivision.gov.bd/site/page/6cd25d49-3150-482a-8bd0-701d18136af71%e0%a6%8f%e0%a6%95-%e0%a6%a8%e0%a6%9c%e0%a6%b0%e0%a7%87>.

## 2.4 Fuel Mix Options in Electricity Generation

Historically, Bangladesh’s fuel mix has been dominated by natural gas. Local availability in line with domestic requirements made the country over-dependent on this single source. The share of natural gas in electricity generation accordingly reached more than 80% by 2009. Even though this share gradually declined due to low gas reserves and implementation of smaller quick-rental power plants, Bangladesh is still heavily reliant on natural gas today. Figure 4 also shows fuel mix share from 2005 to 2020 for a grid-based generation. In 2020, the share of natural gas was the highest among all (56%), followed by Furnace Oil (FO) (27%) and High-Speed Diesel (HSD) (6%). Coal accounted for 3% of the electricity generation mix in 2020. However, the relative share of renewables shows a declining trend for the last 15 years as it stood only at 1.36% in 2020 in the electricity generation mix.

## 2.5 Move towards Competitive Market Environment and Investment Trend

Despite landmark achievements gained in the electricity generation capacity, Bangladesh still has a long path ahead to create a competitive market



**Fig. 4** Electricity generation fuel mix in Bangladesh from 2005 to 2020. (Source: Bangladesh Economic Review (BER) (2020))

environment as many energy utilities are still under the control of the state and have little operational or financial independence. On many occasions, the government influences the regulatory commission to fix the energy prices, which are not formulated following economic principles but based on vested interests and political motives. Due to imperfect or politically influenced pricing without any regard to cost, and operational inefficiencies in the absence of a competitive market, the state-owned power companies face losses, limiting investment in the energy sector. For instance, the Bangladesh Petroleum Corporation (BPC) net loss due to the fuel subsidies was USD 209 million in 2020.<sup>19</sup>

Moreover, since the per-unit cost of electricity generation increased after 2009 due to moving away from highly subsidized natural gas and the heavy use of imported liquid fuels, the Bangladesh Energy Regulatory Commission (BERC) has made several adjustments to balance both wholesale and retail electricity markets.<sup>20</sup> Recently, BERC has implemented a benchmark pricing system to attract private participation in electricity generation, making Bangladesh the first South Asian country to introduce this pricing system. Since the administered prices of locally available natural gas are set at levels significantly below that of the international market and remain very low in regard to the opportunity cost in respect of imported-fuel equivalence, the gas prices have also increased five times between 2009 and 2020 after moving towards a more competitive market environment.

It is also argued that the effort from the government in ensuring competition can be reflected in the overall performances of the energy sector in terms of system losses, generator availability, non-technical energy losses, accessibility of service, investment, price levels and structures, and service quality. The 6th, 7th, and 8th Five Year Plans (FYP) of Bangladesh report an increasing trend in private investment due to the price reform initiatives in the last 10 years.<sup>21</sup> However, the investment has increased mainly in the generation sector, backed by generously negotiated Power Purchase Agreements through collusive contracting virtually eliminating all market related risks and costing the Bangladeshi taxpayers approx.

---

<sup>19</sup> <http://www.bpc.gov.bd/>

<sup>20</sup> For more details, see: <http://www.berc.org.bd/>

<sup>21</sup> On the 6th FYP see: <http://socialprotection.gov.bd/wp-content/uploads/2017/06/SFYP-Final-Part-1-17-08-111.pdf>. On the 7th FYP, see: [https://www.unicef.org/bangladesh/sites/unicef.org/bangladesh/files/2018-10/7th\\_FYP\\_18\\_02\\_2016.pdf](https://www.unicef.org/bangladesh/sites/unicef.org/bangladesh/files/2018-10/7th_FYP_18_02_2016.pdf). On the 8th FYP, see: <https://bnnrc.net/bangladesh-eighth-five-year-plan-july-2020-june-2025-has-published-eversion/>. The share of public investment in the energy sector in the Annual Development Program (ADP) allocation also increases since 2010.

USD 1bn yearly in subsidies for fossil-fuel based electricity generation (Khan et al., 2020). Given the present situation, the viable option is to open up the transmission and distribution sectors for private investment.<sup>22</sup>

Jamasb (2002) argues that privatization at the distribution and transmission utilities may be introduced at a later stage of the reform initiatives and will enhance further efficiency improvement for any country that has already significantly ensured private participation in the generation sector. With the significant progress in private power generation over the last one decade, it is time to deliver effective competition through private sector participation in the distribution and transmission sector. It is estimated that USD 216 billion would be needed for the generation, transmission, and distribution sector by 2041 (Power Cell, 2016).<sup>23</sup> Given the fact that the PGCB stands alone for confronting all emerging challenges in transmission sector, the Bangladesh government should plan for opening up the sector for private investment.<sup>24</sup>

---

### 3 Energy Market Reforms in Bangladesh

Having realized the importance of the energy sector, most developing and emerging countries started considering energy market reform as part of broader strategies towards a market economy since 1990 (Erdogdu, 2010; Newbery, 2004; Jamasb, 2006). Bangladesh also underwent a range of institutional reforms in the energy sector in the last 50 years. The government restructured the energy market with the unbundling of the sector by creating different publicly owned utilities for generation, transmission, and distribution firms; inviting the IPPs to stabilize the generation shortage faced by the state-owned companies; corporatizing of the core power utility; establishing an independent regulatory authority; and implementing large-scale power generation plants.

---

<sup>22</sup>Amin et al., (2021b) report that private investment shows a better performance than government investment in increasing energy consumption in South Asia.

<sup>23</sup>For more details about investment potentials in the Bangladesh power sector (as of 13th June 2019), see: <http://www.powercell.gov.bd/site/page/8bf3f2bf-cdc8-4235-b2ca-1e8e39e3e7df/>.

<sup>24</sup>For more details, see: <https://ep-bd.com/view/details/article/NjAyMA%3D%3D/title?q=open+up+power+transmission+to+private+investment>.

### 3.1 Policies to Facilitate Reform Initiatives

The energy market reform programs in Bangladesh were claimed to be successful, as the reforms had been experiencing a process of remarkable institutional shift since the country's independence. During the 1970s and 1980s, the responsibility of the BPDB had been shared with the Rural Electrification Board (REB) for electrifying rural Bangladesh. In 1994, the Power Sector Reform in Bangladesh (PSRB) was formed, which outlined a reform process focusing on institutional issues. The National Energy Policy (NEP) was the first formal energy policy in Bangladesh, adopted in 1996 (followed by a revised version in 2004) to develop the overall structure for improving the sector. It also advocated for developing energy infrastructures, sectoral unbundling to achieve efficiency, increase in indigenous energy supply, institutional and policy reforms, energy conservation and efficient use, and implementation strategies.<sup>25</sup>

In 1996, the Private Sector Power Generation Policy<sup>26</sup> of Bangladesh was adopted which attracted national and foreign private investment for electricity generation. Following this policy, the IPPs entered the energy market after October 1996. In 1998, the policy guidelines for SPPs<sup>27</sup> were taken into consideration for further mobilization of the private resources. Besides, Private Sector Infrastructure Guidelines<sup>28</sup> were adopted in 2004 to enable procurement and implementation of private infrastructure projects by documenting a set of guidelines, and monitoring and expediting the implementation through institutional arrangements. Bangladesh also adopted policies for purchasing electricity from the CPPs in 2007.<sup>29</sup>

---

<sup>25</sup> For more details about NEP, see: Amin (2015).

<sup>26</sup> For more details, see: [https://www.bpdb.gov.bd/bpdb\\_new/d3pbs\\_uploads/files/11%20March%2019/1.%20PSEPGPB.pdf](https://www.bpdb.gov.bd/bpdb_new/d3pbs_uploads/files/11%20March%2019/1.%20PSEPGPB.pdf).

<sup>27</sup> For more details, see: [https://berc.portal.gov.bd/sites/default/files/files/berc.portal.gov.bd/policies/9ddbabab\\_e084\\_464d\\_9511\\_46c0364d0ac4/Policy%20Guidelines%20for%20SPP.pdf](https://berc.portal.gov.bd/sites/default/files/files/berc.portal.gov.bd/policies/9ddbabab_e084_464d_9511_46c0364d0ac4/Policy%20Guidelines%20for%20SPP.pdf).

<sup>28</sup> For more details, see: [https://berc.portal.gov.bd/sites/default/files/files/berc.portal.gov.bd/policies/bf23784c\\_4f48\\_4520\\_ace0\\_59667f00838f/Private%20Sector%20Infrastructure%20Guidelines.pdf](https://berc.portal.gov.bd/sites/default/files/files/berc.portal.gov.bd/policies/bf23784c_4f48_4520_ace0_59667f00838f/Private%20Sector%20Infrastructure%20Guidelines.pdf).

<sup>29</sup> For more details, see: <https://www.adb.org/sites/default/files/publication/692451/adbi-wp1238.pdf>.

Bangladesh undertook three major PSMPs in 2005, 2010, and 2016 to achieve its energy sustenance goals and meet the energy demands.<sup>30</sup> The main objectives of adopting these PSMPs were to shift to a more comprehensive and mid-long-term planning for meeting the future energy generation by augmenting the challenged in the immediate and interim period (Tamim et al., 2013). Initially, the PSMP 2005<sup>31</sup> mainly focused on increasing the generation capacity by utilizing domestically produced natural gas. However, due to the depleting stock of natural gas, the PSMP 2010<sup>32</sup> shifted the focus on strengthening the energy diversification process for electricity generation by tapping all the possible fossil and non-fossil fuel sources. Finally, PSMP, 2016<sup>33</sup> dedicated on developing the infrastructural development for energy import and human capital development and increasing renewable energy share in the electricity generation mix for stable energy supply. Paltsev (2020) argues that energy and industrial firms, governments, think tanks and other stakeholders must position their strategies with science-based goals while perusing economic growth together with reliable and affordable energy.

The Renewable Energy Policy (REP)<sup>34</sup> was adopted in 2008 to recognize the importance of renewable energy to remove the disparity between urban and rural areas, increase the contribution of renewable energy by setting targets, and developing the local authority. In 2011, the Power and Energy Sector Road Map<sup>35</sup> was implemented that outlined the updated strategies for revamping the power and energy sector. More recent policies included the Energy Efficiency and Conservation Master Plan up to 2030 in 2015,<sup>36</sup> the Gas Sector Master Plan in 2017,

---

<sup>30</sup> However, according to the PP 2021–2041, there were 2 earlier versions of the PSMP adopted in 1985 and 1995.

<sup>31</sup> For more details, see: <https://policy.asiapacificenergy.org/sites/default/files/Power%20System%20Master%20Plan-2005.pdf>.

<sup>32</sup> For more details, see: <https://policy.asiapacificenergy.org/node/249>.

<sup>33</sup> For more details, see; <https://powerdivision.gov.bd/site/page/f68eb32d-cc0b-483e-b047-13eb81da6820/Power-System-Master-Plan-2016>.

<sup>34</sup> For more details, see; [http://policy.thinkbluedata.com/sites/default/files/REP\\_English.pdf](http://policy.thinkbluedata.com/sites/default/files/REP_English.pdf).

<sup>35</sup> For more details, see; [https://policy.asiapacificenergy.org/sites/default/files/Roadmap\\_power\\_energy\\_2010.pdf](https://policy.asiapacificenergy.org/sites/default/files/Roadmap_power_energy_2010.pdf).

<sup>36</sup> For more details, see: [https://policy.asiapacificenergy.org/sites/default/files/EEC\\_Master\\_Plan\\_SREDA\\_2.pdf](https://policy.asiapacificenergy.org/sites/default/files/EEC_Master_Plan_SREDA_2.pdf).

the Electricity Act<sup>37</sup> in 2018, the Quick Enhancement of Electricity and Energy Supply (Special Provisions) Act<sup>38</sup> in 2018, and the 8th Five Year Plan in 2020 for the next five years' energy sector development targets. Guidelines for further improvement of the energy sector as well as for ensuring energy security level are also discussed in the 2<sup>nd</sup> Perspective Plan of Bangladesh 2021–2041 (GED, 2020)<sup>39</sup> and Bangladesh Delta Plan (BDP) 2021 (GED, 2018). BDP 2021<sup>40</sup> targets to develop long-term renewable energy policies and construct a master plan for at least 50 years and is expected to play a crucial role in attaining future energy security of Bangladesh by harnessing the potentials of the renewable energy resources through public and private investments.

## 3.2 Energy Sector Reforms in Bangladesh

The main reform initiatives in Bangladesh include restructuring the core utilities, the undergoing institutional reform, ensuring privatization, and establishing independent regulatory bodies (Fig. 5).

### 3.2.1 Institutional Reforms

In 1998, the Ministry of Power, Energy, and Mineral Resources (MPEMR) was divided into two divisions, the Energy and Mineral Resources (EMR) Division and the Power Division (PD), to improve institutional efficiency. Moreover, Power Cell was formed in 1995 to support PD of MPEMR in monitoring and implementing reform projects, helping different stakeholders for future sectoral activities, and attracting private investment. For facilitating renewable energy

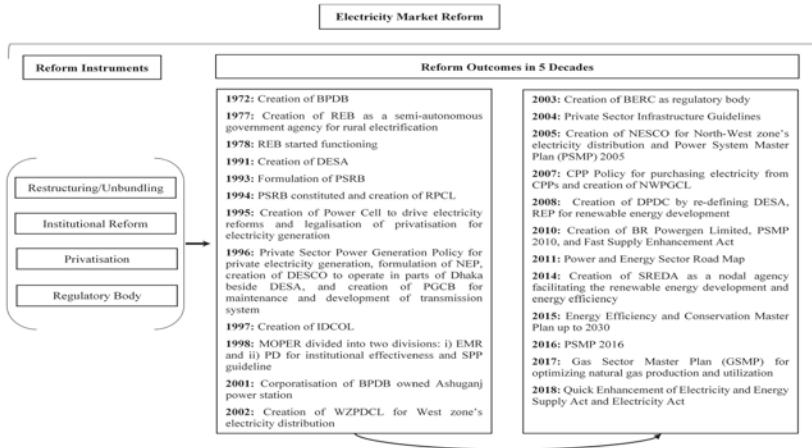
---

<sup>37</sup> For more details, see: [https://powerdivision.portal.gov.bd/sites/default/files/files/powerdivision.portal.gov.bd/page/18d2690b\\_f02f\\_4c35\\_8f90\\_79b70d333242/ELECTRICITY%20ACT,%202018.pdf](https://powerdivision.portal.gov.bd/sites/default/files/files/powerdivision.portal.gov.bd/page/18d2690b_f02f_4c35_8f90_79b70d333242/ELECTRICITY%20ACT,%202018.pdf).

<sup>38</sup> For more details, see: [https://www.dpp.gov.bd/upload\\_file/gazettes/18893\\_67482.pdf](https://www.dpp.gov.bd/upload_file/gazettes/18893_67482.pdf).

<sup>39</sup> More details can be found at: <http://oldweb.lged.gov.bd/UploadedDocument/UnitPublication/1/1049/vision%202021-2041.pdf>.

<sup>40</sup> To know more about BDP 2100, see: <https://oldweb.lged.gov.bd/UploadedDocument/UnitPublication/1/756/BDP%202100%20Abridged%20Version%20English.pdf>. BDP 2100 is a long-term holistic and integrated plan approved by Bangladesh in 2018. The key objectives of the BDP are aligned with SDG Goal 2, 6, 13, and 14 and complemented by the policies in the 8th Five Year Plan and the 2nd Perspective Plan (2021–41) in achieving Bangladesh's Vision for 2041. See: <https://thefinancialexpress.com.bd/views/bangladesh-delta-plan-2100-implementation-challenges-and-way-forward-1553354695>.



**Fig. 5** Reform outcomes in Bangladesh. (Source: Authors own elaboration)

development, the government created the Sustainable and Renewable Energy Development Authority (SREDA) in 2014 as a nodal agency but to date has not decided to provide the same with a ministerial status, which is the case with other countries (e.g. India’s Ministry of New and Renewable Energy).

### 3.2.2 Restructuring of the Core Utilities

The restructuring of the core power and energy utilities has played a crucial role for the Bangladesh energy sector, briefly discussed below.

#### Generation Utilities

In 1972, the Bangladesh Power Development Board (BPDB) was established as a public sector organization for power generation and transmission and electricity distribution across the country. Before 1995, electricity was generated only by the public utilities under BPDB; however, the share of private companies in electricity generation became significant from 1995. According to the 2020 annual report of the BPDB, 44.47% of the total electricity was generated by the private sector in 2019. For adequate electricity generation and to improve administrative efficiency, BPDB has been continuously unbundling throughout the last 50 years. For example, currently, Ashuganj Power Station Company Limited (APSCL), North-West Power Generation Company Limited (NWPGL), BR Powergen Limited,



and Rural Power Company Limited (RPCL) work as a subsidiary of BPDB in power generation.<sup>41</sup>

### **Distribution Utilities**

The establishment of the Rural Electrification Board (REB) in 1978 was the first restructuring initiative in the distribution sector to provide electricity in rural areas. Recently, around 80 collaborative organizations [Palli Bidyuit Samity (PBS)] in rural areas have contributed to additional connections and forming distribution lines for increasing rural electricity accessibility. BPDP further underwent unbundling in 1991 to create the public company Dhaka Electric Supply Authority (DESA) with an intention to provide better services to Dhaka and surrounding areas. However, a new entity DESCO (Dhaka Electric Supply Company), emerged after 5 years in 1996, and started distributing electricity besides DESA. Such further unbundling was done to achieve better management of resources and to enhance consumer satisfaction. In 2008, DESA was redefined as the Dhaka Power Distribution Company (DPDC) with new objectives to attain the increasing energy demand. West Zone Power Distribution Company Limited (WZPDCL) was established in 2002 for distributing electricity to Khulna and Barisal divisions. Furthermore, NESCO (Northern Electricity Supply Company Limited) was established in 2005 for the divisions of Rangpur and Rajshahi.

### **Transmission Utilities**

The Power Grid Company of Bangladesh (PGCB) was created (unbundling from BPDB) in 1996 (under the Companies Act 1994) to act as a separate transmission utility in the energy sector. The main reason for such separation was to bring efficiency in operational activities, maintenance, and the development of transmission infrastructure all over the country.

### **3.2.3 Independent Regulatory Body**

One of the key reform initiatives in Bangladesh was to establish the independent regulatory authority (BERC) in 2003 through a legislative Act of the Government of Bangladesh. As a regulatory body, BERC is responsible for fixing the tariff rates of electricity, and other resources such as coal and natural gas. BERC also

---

<sup>41</sup>For more details, please see: [https://www.bpdb.gov.bd/bpdb\\_new/index.php/site/page/13e9-2cc0-ce41-9c09-088d-94d5-f546-04a6-b4fa-1d18](https://www.bpdb.gov.bd/bpdb_new/index.php/site/page/13e9-2cc0-ce41-9c09-088d-94d5-f546-04a6-b4fa-1d18).

guides different policy formulations done by other entities of the energy sector. It is also worth mentioning that the BERC promotes a competitive market environment and protects consumer rights.

---

## 4 Existing Controversies

Although Bangladesh initiated different reform initiatives since independence to strengthen the energy sector and quicken the developmental activities' pace, these initiatives became more visible since 2009 as the government targeted 100% electrification by 2021. Although the government successfully resolved the historical energy crisis in terms of its limited generation capacity, this success raised concerns regarding several controversies briefly discussed below.

### 4.1 Quick Rental (QR) Power Plants and Increase in Liquid Fuel Consumption

The government introduced the QR power plants in 2010 as a quick solution to reduce the then persistent electricity crisis. This policy of introducing the QR power plants has been a success by providing an intermittent electricity supply. However, these QR power plants burn oil to produce electricity, and oil imports have increased by almost 400% over the last ten years (BPDB, 2020). Since the government provides subsidies to the QR power producers for oil, the size of the fuel subsidies soared during this period. The average cost of electricity generation has also increased 2.5 times during the last ten years. Moreover, the increased usage of imported oil exposes the country to oil price shocks in the global market. Amin (2015) reveals that the Bangladesh economy is indeed vulnerable to oil price shocks as increased oil prices have an adverse effect on household welfare which reduces overall consumption and output.

Experts criticize that although the QR power plants were given licenses on a three-to-five-year basis, nine QR power plants with a cumulative generation capacity of almost 1GW continue to supply electricity to the national grid for over a decade now despite the country's vast amounts of excess electricity in recent years. Amin et al. (2019) reveals that shutting down the QR power plants will be welfare-enhancing for Bangladesh's economy and suggest that the Bangladesh government should start shutting down QR power plants and switch to alternative sources.

## 4.2 Low Reserve of Natural Gas and Issue with LNG

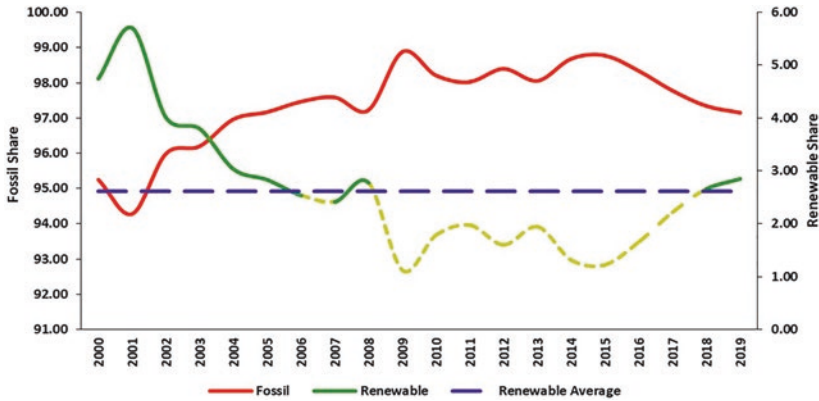
Following the oil price shocks in the 1970s, natural gas became the energy of choice in Bangladesh until 2008. Although the country has faced a diminishing trend in natural gas usage in electricity generation due to the fuel diversification process, the share is still large (55.89%) compared to global standards of 23%, raising the fear of resource depletion. There is a growing concern among the experts that Bangladesh is now at risk of depleting the limited natural gas reserve due to the lack of technical skills, which acts as a hindrance in discovering new gas fields. Therefore, the government aims to continue discovering new gas fields, exploring more natural resources from the offshore blocks, and ensuring natural gas structure in collaboration with foreign companies.

Given this background, the Bangladesh government attached high priority to LNG-based power generation to fill the demand and supply gap. Bangladesh now has two floating storage and regasification units (FSRUs) with a total capacity of 7.5 million tons a year. The country is also developing a land-based terminal that can handle 7.5 million tons per annum (MTPA) of LNG, which is expected to be prepared in 5 years. Bangladesh plans to generate approximately 11% of total electricity from the LNG power plants by 2041.

The existing pipeline, however, is considered too small to accommodate future natural gas delivery. Moreover, the LNG price is still considerably high, which can distort the market environment and result in a vicious subsidy regime in the future. On the other hand, the operating cost of FSRUs is much higher due to the high charter rates of the ships that bring LNG to Bangladesh. Given all these adversities, the higher dependency on LNG as an alternative fuel option remains questionable. The government is likely to observe progress with the LNG expansion scheme and revise the policy as required in the context of the upcoming PSMP before allowing for large-scale investments for electricity generation from LNG.

## 4.3 Slow Progress in Renewable Energy Development

Despite the huge success in the dissemination of SHS proving solar-powered electricity access to more than 25 million rural Bangladeshis, the increasing global trend of renewable energy generation capacity as a significant part of the energy mix has not yet been observed in Bangladesh. Figure 6 shows a gloomy picture as the share of renewable energy in the electricity generation mix declined



**Fig. 6** Fossil versus renewable energy use for electricity generation. (Source: World Development Indicators (2020) and SREDA (2020a))

sharply after 2001. From 2009 to 2016, the average share of renewable energy in the electricity generation mix remained 1.58% (yellow dotted line), which is lower than the average share (2.61%) of renewable energy from 2000 to 2019.

Although renewable energy has been given priority in the different power sector master plans, the renewable energy share is yet to increase beyond the mere three percent. It is worth noting that the share of renewable energy in the total generation was above the average share of renewable energy. One of the main reasons was that Bangladesh generates approximately 200 MW of electricity with the hydro plant from the Kaptai lake due to the flat terrain. However, the increased electricity generation capacity over the years pushed down the renewable share. A closer look at other literature and case studies find that many existing socio-economic and institutional barriers limit the growth of the renewable energy market in Bangladesh from both the demand and supply sides. Market barriers remain another key impediment behind the development of renewable energy in Bangladesh. For example, institutional reforms should come from regulatory legitimacy.<sup>42</sup> Too many institutional segmentations within a centralized set-up are a common feature observed in Bangladesh, like most Asian countries.

<sup>42</sup>Amin et al. (2021a) argues that “Regulatory legitimacy refers to formal rules, compliances, and bureaucratic effectiveness.” It is considered as one of the fundamental aspects that determines government dynamics in an economy.

Institutional ambiguity in the energy sector have also led to the slow progress of renewable promotion, generation, and dissemination. Among others, institutional collaborations, infrastructure facilities, monitoring capacity, credit access, after-sales services, quality assurance, pricing issues, and technical issues must be adequately addressed for a sustainable renewable energy market in Bangladesh.

Another important reason behind the inaction in renewable energy development is the poor allocation in the ADP of Bangladesh while formulating energy policies. The 2020 statistics data from the Ministry of Finance<sup>43</sup> shows that between 2015 to 2020, the average share of renewable energy in ADP allocation was only 5.80%, whereas the average allocation of fossil energy in the same period was astonishingly 94.20%. Furthermore, expenditure allocation for Sustainable and Renewable Energy Authority (SREDA) has remained marginal. On average, SREDA received only USD 0.73 million from 2015 to 2020 (SREDA, 2020a), which was approximately 0.03% of the total allocated budget. These points raised above beckon the question of whether the often-cited scarcity of land as the main hindrance to a larger uptake of solar PV (Shiraishi et al., 2017; SREDA, 2020b) really tells the whole story or whether strong elements of stakeholders with vested interests in retaining the status quo are at play.<sup>44</sup> However, according to the PP2041, the government plans to considerably amend and strengthen the renewable policies by learning lessons from experience, encouraging private investors to generate and households to consume renewable energies through different incentives. Several options have been planned to explore the increase in renewable energy, such as offshore wind, tidal energy, waste to energy, etc.

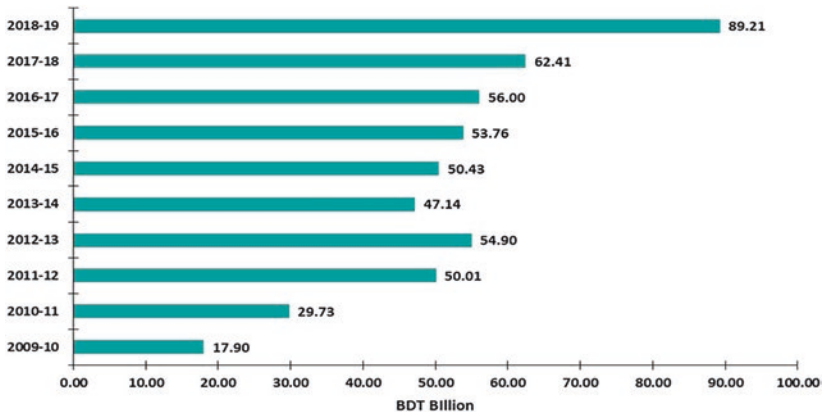
#### 4.4 Overcapacity in Generation and Issue of Capacity Charge

Bangladesh has maintained a surplus of 40% electricity for the past few years, although the global accepted level of overcapacity is 20% (GED, 2020). One of the main causes for overcapacity is the mismatch between the demand–supply

---

<sup>43</sup> For more details, see: <https://mof.gov.bd/>

<sup>44</sup> For more details, see: <https://thefinancialexpress.com.bd/trade/land-scarcity-key-barrier-to-dev-of-renewable-energy-1552062684> and <https://www.tbsnews.net/feature/panorama/solar-power-not-enough-land-consider-highways233173#:~:text=The%20biggest%20problem%20facing%20Bangladesh,options%20in%20Bangladesh%20are%20negligible.>



**Fig. 7** QR capacity charge over the years. (Source: BPDB (2020))

prediction and the inaccurate forecasting methods used in the PSMP. The economic inaction associated with the Covid-19 pandemic has also reduced the overall energy demand of the country. The overcapacity problem is also linked with capacity charges, as the government has to pay a significant amount of money as a capacity charge to the idle QRs to cover up their losses, leading to upward pressure in electricity prices.<sup>45</sup> Figure 7 further shows that the capacity charge has increased since 2014, and the government paid USD 1.06 billion as a capacity charge, which is the maximum value ever recorded. According to the officials of the BPDB, 35% of overcapacity is needed in Bangladesh for several reasons. For example, 5% electricity is required for the plant's own use, 10% for maintenance, 10% for spinning capacity, and another 10% for system loss.<sup>46</sup> Moreover, overcapacity is needed because of the difference in seasonal consumption (peak summer vs. peak winter). Given that the demand may rise once the Covid-19 pandemic is over, the overcapacity in generation in Bangladesh may be seen as a way to avoid any future supply shortage, albeit a costly strategy.

<sup>45</sup> For more details, see Speedy Supply of Power and Energy Act of 2010. [https://www.dpp.gov.bd/upload\\_file/gazettes/18893\\_67482.pdf](https://www.dpp.gov.bd/upload_file/gazettes/18893_67482.pdf).

<sup>46</sup> See: <https://www.thedailystar.net/backpage/news/power-generation-overcapacity-new-headache-2032377>.

## 4.5 Subsidy Issues

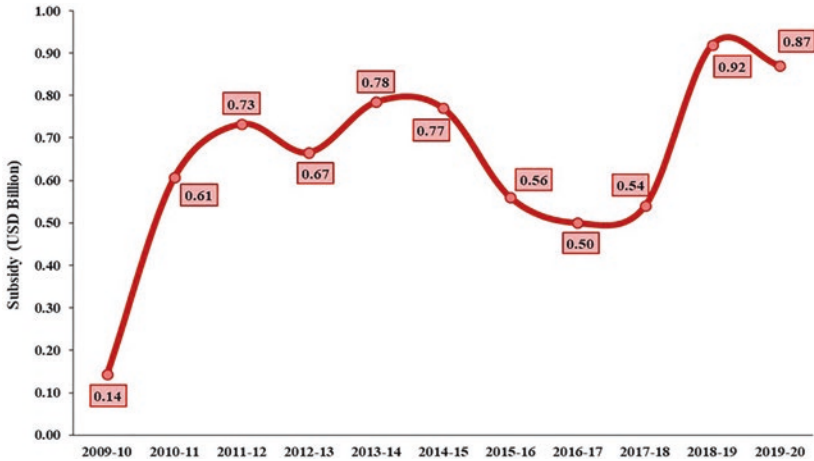
Ahmed et al. (2016) highlights that the energy sector in Bangladesh is constrained by the prevalence of high subsidies and distorted energy prices. Many government power companies in Bangladesh are in severe financial need, which causes upward pressure on the national budget. The government has to support these institutions by providing subsidies, which adversely affect the government's potential to finance expenditure on education, health, and social protection. Moreover, when there was a rise in the global oil price, the government could not transfer the higher cost to the consumers. This caused an upward gap between the average cost of oil commodities and the selling price to the consumers. Accordingly, the subsidy bill of the government soared. For instance, BPC had historically suffered losses because of the non-adjustment of oil price in the local market in accordance with oil price increases in the international market. Consequently, the government had to provide large yearly subsidies for importing petroleum products during those periods.<sup>47</sup>

It is also worth noting that the electricity tariff structures in Bangladesh vary across sectors and consumption levels. Amin (2015) argues that industrial and commercial sectors pay higher tariffs while domestic and agriculture sectors pay low subsidized tariffs. According to the 2020 statistics of the Power Division, the total subsidy in 2015–16 was USD 0.56 billion, which increased to USD 0.87 billion in 2020 due to the increased generation cost. The subsidy for imported fossil fuels is still a significant burden for the Bangladesh energy sector. The average amount of subsidy allocated for the energy sector for the last 10 years is approximately USD 0.76 billion (Fig. 8).

The debates are ongoing in how far subsidies actually help the poor due to energy subsidy's inefficient and inequitable nature (IMF, 2013). Most of the benefits of fuel subsidies tend to go to the affluent who can then buy more fuel (Granado et al., 2012). Moltke et al. (2004) discuss that those cross-subsidies may reduce industrial firms' global competitiveness, compelling them to pay higher tariffs and, consequently, hinder economic development. Jamasb and Nepal (2015) also make the point that cross-subsidies from industrial to residential users are not economically desirable. However, any policy revisions regarding subsidy

---

<sup>47</sup>Nevertheless, the government did not have to provide any subsidy between 2016 and 2018 due to the declining international oil prices. However, during 2019, the prices began to rise again, and the BPC started incurring losses from furnace oil and diesel.



**Fig. 8** Electricity subsidy in Bangladesh 2009–2019. (Source: Power division (2020))

removal are not easy and need to be introduced from equity consideration since most developing countries face difficulty in reducing or removing them, often because of the political unrest their withdrawal causes. BERC has made several adjustments during the past few years to maintain financial discipline in the sector and protect consumers' interests. However, the increasing trend of electricity prices will continue unless efficiency and other cost measures are considered. It is argued that adequate pricing of fossil fuels is necessary to foster generation, the use of green energy options, and to meet Bangladesh's environmental objectives, including its commitments to the Paris Accord on Carbon Emission Reduction (GED, 2020).

#### 4.6 Demand Forecasting Methods

Due to the unplanned urbanization, the rapid industrialization, the existence of a large informal economy and the urban–rural divide, it is very difficult to maintain the generation target as forecasted in the demand estimations. Moreover, since the government introduced rigorous rural development programs, the energy used in the rural area (especially rural non-farm sectors) also increased significantly. Rural energy demands, however, are significantly more difficult to capture through econometric models (Bhattacharyya & Timilsina, 2009).



## 5 Conclusion and Priority Actions

It is recommended that the Bangladesh government continue adopting coordinated policies to ensure that the further development of the energy sector is aligned with the development momentum pace. Bangladesh should strive to achieve a more efficient, environmentally friendly, and least-cost fuel mix in its electricity generation. It is worth noting that coal power is not a cheap option as the costs of renewables have been undercutting coal for years. The BDP 2021 targets to produce a minimum of 30% energy generation from renewable sources by 2041 and plans to prepare a master plan for at least 50 years to exploit the potential of renewable sources in the country incorporating public and private investments.

Nuclear power production is also included in the Bangladesh government's agendas to increase the generation capacity in meeting the growing electricity demand. The Rooppur nuclear power plant is expected to generate the first 1200 MW nuclear power by 2024. However, there are concerns regarding the safety issues as critics find it to be a massively risky venture for Bangladesh, which could severely affect the safety of millions of people in this densely populated country and strain external payment's sustainability. Therefore, the government should carefully review the action with nuclear power and, if required, revise the PSMP to revolutionize their energy production through renewables by providing the consumers and the private sector with a proper incentive structure to create a sustainable renewable environment. Accordingly, the continued staggering dependency on fossil fuels needs to be decreased to compete with the progress made by global clean energy usage.

Petroleum products and gas also have severe pricing issues in Bangladesh. Despite numerous adjustments, the gap between average cost and price is still sizable. BPC imports crude and refined oil every year according to the country's demand. Given the volatility of the global fossil fuel markets, a high risk of financial debt will continue unless there are regular price adjustments.

Furthermore, adequate pricing of fossil fuel commodities is vital to promote products, clean fuel options, to gain energy efficiency, and financial sustainability. Globally, it is well acknowledged that subsidized fossil fuel has given rise to excessive carbon emission and discouraged the adoption of clean technology and investments in renewable energy (Beyer et al., 2020; Surge et al., 2020). It is worth noting that Indonesia's innovative policy of inclusive fossil fuel subsidy removal, initiating direct social welfare strategies to assist its poorest citizens while following a green energy policy may serve as an example. Therefore, price

reform and the gradual withdrawal of the subsidies will permit Bangladesh to advance to a competitive and environmentally sustainable least-cost power generation, transmission, and distribution system together with greater private involvement, owning resource mobilization to lessen the dependence on finite financial resources and to meet the environmental goals of Bangladesh including its devotion to the Paris Accord on Carbon Emission Reduction.

For further development of renewable energy, the government's emphasis on a low-carbon development path also needs to be reflected in its budget allocation. Moreover, innovative financing schemes for grant funding and low interest financing for interventions targeted to make the country's current grid infrastructure smarter, e.g., innovations in decentralized storage technologies for more grid flexibility, should receive strong support. Furthermore, least cost technology for bridging the gap between on-grid and off-grid renewable energy projects ought to be implemented. Existing support programs through institutions like IDCOL and Investment Financing Facility for Private sector (IFFP) should be further strengthened. The government should focus on the adoption of Electric Vehicles (EV) for road transport, including the 1.5 M+ already existing electric three-wheelers, and reverse the trend of recent bans toward those vehicles to a conducive policy framework facilitating a safe and clean adoption of the same. Moreover, a framework for connecting solar home systems into the grid, integrated electrification planning should receive increased financial and policy support. The existing market barriers surrounding the renewable energy sectors also need to be addressed adequately, creating at least a level playing field. Waste to Energy (WtE) power plants could also be prioritized and implemented thoroughly throughout Bangladesh, as it creates massive potential in renewables in the country. Additionally, mobilization of adequate financial resources should be considered, including the proper mobilization of private finance for investments in indigenous renewable energy and other energy infrastructure development.

Policies such as liberal trade regimes (bilateral or multilateral), customized financial motives for clean technology, and Cross-Border Electricity Trading (CBET) can also bring improvement in the energy security level (Pan et al., 2019; Jamasb et al., 2015). With a harmonized policy framework and creating regional solid energy cooperation, Bangladesh can access the hydropower generated in Nepal and Bhutan channeled through India, and other resources to reduce the country's primary electricity generation fuels and associated resources risks. It is worth noting that such diversification through trading collaboration will help Bangladesh to lessen the possibility of power supply disruption from conflict and accidents. However, the government has to be cautious since the success of the

CBET depends on the political relations of the trading partners and the volatility of energy prices.

According to the 8th FYP, till now, only 27 gas fields have been discovered in Bangladesh. However, about 50 unexplored gas blocks (17 onshore and 22 offshore) from which a good amount of natural gas can be extracted to generate electricity and provide energy to other priority sectors, also exist. The cost of exploration and development of untapped resources is likely to be lower than LNG import. To undertake exploration and development of undiscovered resources, external support may be needed. To address such technical and financial issues, Joint Venture or “Strategic Partnership” between BAPEX and foreign companies may be sought through a Production Sharing Agreement with IOCs to pursue both onshore and offshore oil and gas options.

We also emphasize private and Public–Private Participation (PPP) projects so that the government can focus on developing other energy-related infrastructure. Besides, the government also needs to accelerate the phasing out of the QR power plants immediately and find alternatives for the LNG to solve the overcapacity and capacity charge issues and expected price distortions associated with the LNG.

Bangladesh should implement large-scale power transmission and distribution systems to stabilize the network voltage fluctuations and frequency problems, create uninterrupted quality power distribution, and install more high-power transmission lines in line with the growing demand and massive supplies originating from new power generation hubs (Payera, Roop Pur, Rampal and Matarbari). Attracting foreign and domestic large-scale private investment and introducing newer innovative solutions should be given utmost priority in the upcoming years for developing the transmission and distribution sector. The government may further look for implementing well-articulated demand-side management (DSM) to ensure cost-effective ways to curtail the peak demand and control load shedding while simultaneously reaching out to consumers to adopt energy-efficient appliances and equipment, and introduce improved energy-efficient technologies and new building insulation standards to meet the energy efficiency targets.<sup>48</sup>

Energy efficiency programs need to be strengthened to promote high-efficiency household appliance sales, awareness programs to induce behavioral changes in consumers to save energy, introducing peak and off-peak tariff systems to reduce peak demand, and implement rigid regulations in large buildings to save energy such as nominating energy managers. Additionally, energy storage

---

<sup>48</sup> For details, please see: <https://openjicareport.jica.go.jp/pdf/12231247.pdf>.

system development can be focused on through further Research and Development (R&D).

Institutional reform needs to be addressed as the lack of organizational power of the decentralized institutions within a centralized system which impedes and slows down policy implementations and private investments (Cai & Aoyama, 2018; Ghafoor et al., 2016; Vijay et al., 2015). Besides, several bureaucratic issues restrict the acceleration of currently enrolled energy-related programs. Hence, following the argument of Jamasb et al. (2016), substantial priorities should be given to coordinated institutional reforms through regulatory legitimacy in energy technology exploration, investment mechanisms, DSM, cross-border negotiations, and energy dissemination programs. Finally, the government might consider adding policies that can be used to develop different skill sets of the existing workforce and train newly enrolled employees in the energy sector to reduce the administrative inefficiencies and reallocate the prevailing subsidies to the development of renewable energies.

---

## References

- Ahmed, S., Sattar, Z., & Alam, K. (2016). Fuel Oil subsidy reforms and oil market deregulation in Bangladesh. *Policy Research Institute (PRI) of Bangladesh: Dhaka, Bangladesh*.
- Ahmed, K., & Kamal, S. M. (2020). Bangladesh at Work: Job Creation and Inclusive Growth in the Era of Covid-19. *Centre for Research and Information*.
- Amin, S., Jamasb, T., & Nepal, R. (2021a). Regulatory reform and the relative efficacy of government versus private investment on energy consumption in South Asia. *Economic Analysis and Policy*, 69, 421–433.
- Amin, S., Ahmed, A., Khan, A. M., & Khan, F. (2021b). Policy paper on the post Covid-19 sustainable energy options for power generation in Bangladesh. *International Energy Journal*, 21(1A), 9–20.
- Amin, S. B., Kabir, F. A., & Khan, F. (2020). Energy-output nexus in Bangladesh: A two-sector model analysis. *Energy Strategy Reviews*, 32, 100566.
- Amin, S., & Khan, F. (2020). Modelling energy demand in Bangladesh: An empirical analysis. *The Journal of Developing Areas*, 54(1), 39–52.
- Amin, S. B., Marsiliani, L., & Renström, T. (2019). Quick rental power plant: Extend or Escape? *Policy Insights*.
- Amin, S. (2015). *The macroeconomics of energy price shocks and electricity market reforms: The case of Bangladesh*. Durham University, UK.
- Amin, S. B., & Rahman, S. (2019). Drivers of energy demand in Bangladesh. In *Energy resources in Bangladesh* (pp. 21–25). Springer, Cham.
- BBS (2018). Recent Statistics. Government of the People's Republic of Bangladesh. Dhaka, Bangladesh.
- Bangladesh Power Development Board (BPDB). (2020). Annual Report. Dhaka, Bangladesh.

- Bhatia, M., & Angelou, N. (2015). Beyond Connections. Energy Access Redefined. Energy Sector Assistance Program. The World Bank. Washington, USA. <https://openknowledge.worldbank.org/bitstream/handle/10986/24368/Beyond0connect0d000technical0report.pdf?sequence=1&isAllowed=y>.
- Bhattacharyya, S. C., & Timilsina, G. R. (2009). Modelling energy demand of developing countries: Are the specific features adequately captured? *Energy Policy*, 38(4), 1979–1990.
- Breyer, C., Bogdanov, D., Aghahosseini, A., Gulagi, A., & Fasihi, M. (2020). On the techno-economic benefits of a global energy interconnection. *Economics of Energy & Environmental Policy*, 9(1), 83–103.
- Cai, Y., & Aoyama, Y. (2018). Fragmented authorities, institutional misalignments, and challenges to renewable energy transition: A case study of wind power curtailment in China. *Energy Research & Social Science*, 41, 71–79.
- Del Granado, F. J. A., Coady, D., & Gillingham, R. (2012). The unequal benefits of fuel subsidies: A review of evidence for developing countries. *World development*, 40(11), 2234–2248.
- Erdogdu, E. (2010). Electricity Market Reform: Lessons for Developing Countries. [https://mpira.uni-muenchen.de/27317/1/MPRA\\_paper\\_27317.pdf](https://mpira.uni-muenchen.de/27317/1/MPRA_paper_27317.pdf).
- Finance Division. (2020). Budget Summary.
- GED. (2020). *Perspective Plan of Bangladesh 2021–2041*. Government of the People's Republic of Bangladesh.
- GED. (2018). *Bangladesh Delta Plan 2100: Bangladesh in the 21st Century*. Government of the People's Republic of Bangladesh.
- Ghafoor, A., ur Rehman, T., Munir, A., Ahmad, M., & Iqbal, M. (2016). Current status and overview of renewable energy potential in Pakistan for continuous energy sustainability. *Renewable and Sustainable Energy Reviews*, 60, 1332–1342.
- Goldemberg, J., Johansson, T. B., Reddy, A. K. N., & Williams, R.H. (1985). Basic Needs and Much More with One Kilowatt Per Capita. *Ambio*, 190–200.
- Groh, S., Pachauri, S., & Rao, N. D. (2016). What are we measuring? An empirical analysis of household electricity access metrics in rural Bangladesh. *Energy for Sustainable Development*, 30, 21–31.
- Groh, S. (2014). The role of energy in development processes—The energy poverty penalty: Case study of arequipa (Peru). *Energy for Sustainable Development*, 18, 83–99.
- Groh, S. (2015). The Role of Access to Electricity in Development Processes—Approaching Energy Poverty through Innovation. PhD Thesis. Doctoral School of Engineering and Science at Aalborg University, Denmark. <https://vbn.aau.dk/en/publications/the-role-of-access-to-electricity-in-development-processes-approa>.
- International Monetary Fund IMF. (2013). *Energy subsidy reform: Lessons and implications*.
- Jamasb, T., Nepal, R., & Timilsina, G. R. (2016). A quarter century effort yet to come of age: A survey of electricity sector reform in developing countries. *The Energy Journal*, 38(3).
- Jamasb, T., Singh, A., Nepal, R., & Toman, M. (2015). Cross-border electricity cooperation in South Asia. *The World Bank*.
- Jamasb, T. (2006). Between the state and market: Electricity sector reform in developing countries. *Utilities Policy*, 14(1), 14–30.
- Jamasb, T. (2002). Reform and Regulation of the Electricity Sectors in Developing Countries. *Cambridge Working Papers in Economics*, (0226).

- Khan, M., Matin, M., Zahan, I., Ashraf, Z., & Ajefu, J. (2020). Cheaper, cleaner power: De-risking as an anti-collusion strategy in Bangladesh. *ACE SOAS Consortium. Working Paper*. <https://ace.soas.ac.uk/publication/de-risking-as-an-anti-collusion-strategy-bangladesh/>.
- Khan, M. F. K. (2021). Win: How Public Entrepreneurship Can Transform the Developing World. <https://www.amazon.com/Win-Public-Entrepreneurship-Transform-Developing-ebook/dp/B08Z4FZCT4>.
- Khatun, F. (2021). Bangladesh's achievements in 50 years and making it meaningful. <https://cpd.org.bd/bangladeshs-achievements-in-50-years-and-making-it-meaningful/>.
- Maheu, J. M., Song, Y., & Yang, Q. (2020). Oil price shocks and economic growth: The volatility link. *International Journal of Forecasting*, 36(2), 570–587.
- Momen, A. K. A. (2021). Perspective plan 2041: Golden Bengal as a label for nation branding. <https://www.tbsnews.net/analysis/perspective-plan-2041-golden-bengal-label-nation-branding-270718>.
- Mujeri, M. K., Chowdhury, T. T., & Shahana, S. (2013). *Energy subsidies in Bangladesh: A profile of groups vulnerable to reform*. Bangladesh Institute of Development Studies.
- Murshid, K. A. S. (2020). *Insights into the Rural Non-Farm Sector of Bangladesh*. White Board, Centre for Research and Information.
- Newbery, D. (2004) Regulatory challenges to European electricity liberalisation. *CMI Working Paper*, (12). University of Cambridge, UK.
- Pachauri, S. (2012). Demography, urbanisation and energy demand. *Energy for development* (pp. 81–94). Springer.
- Paltsev, S. (2020). Projecting energy and climate for the 21st Century. *Economics of Energy & Environmental Policy*, 9(1), 43–63.
- Pan, X., Uddin, M. K., Han, C., & Pan, X. (2019). Dynamics of financial development, trade openness, technological innovation and energy intensity: Evidence from Bangladesh. *Energy*, 171, 456–464.
- Power Cell. (2016). Annual Report 2016–2017.
- PSMP. (2016). Power Division, Ministry of Power, Energy and Mineral Resources, Government of the People's Republic of Bangladesh.
- Rehman, S. A. U., Cai, Y., Mirjat, N. H., Walasai, G. D., & Nafees, M. (2019). Energy-Environment-Economy Nexus in Pakistan: Lessons from a PAK-TIMES model. *Energy Policy*, 126, 200–211.
- Samad, H. A., & Zhang, F. (2018). Heterogeneous effects of rural electrification: Evidence from Bangladesh. *World Bank Policy Research Working Paper*, (8102).
- Shiraishi, K., Shirley, R. G., & Kammen, D. M. (2017). Geospatial multi-criteria analysis for identifying high priority clean energy investment opportunities: A case study on land-use conflict in Bangladesh. *Applied Energy*, 235, 1457–1467.
- Sobhan, R., (2021). *Untranquil recollections: Nation building in post-liberation Bangladesh*. SAGE Publishing India.
- Sorge, L., & Neumann, A. (2020). Beyond the inverted U-shape: Challenging the long-term relationship of the environmental Kuznets Curve hypothesis. *Economics of Energy & Environmental Policy*, 9(2), 165–180.
- Steckel, J. C., Brecha, R. J., Jakob, M., Strefler, J., & Luderer, G. (2013). Development without energy? Assessing future scenarios of energy consumption in developing countries. *Ecological Economics*, 90, 53–67.

- Sustainable Energy for All (SE4ALL). (2019). *Integrated Electrification Pathways for Universal Access to Electricity: A Primer*. Vienna, Austria. <https://www.seforall.org/publications/integrated-electrification-pathways-for-universal-access-to-electricity>.
- Sustainable And Renewable Energy Development Authority (SREDA). (2020a). *Recent Statistics*. Dhaka, Bangladesh.
- Sustainable And Renewable Energy Development Authority (SREDA). (2020b). *National Solar Energy Action Plan 2021–2041*. Dhaka, Bangladesh.
- Tamim, M., Badruddin, N. M., & Chowdhury, P. M. (2013). *Bangladesh energy sector primer*. BRAC EPL Research.
- Vijay, V. K., Kapoor, R., Trivedi, A., & Vijay, V. (2015). Biogas as clean fuel for cooking and transportation needs in India. *Advances in bioprocess technology* (pp. 257–275). Springer.
- World Development Indicators. (2020). Data Bank.

## Further Reading

- Bangladesh Economic Review (BER). (2020). Annual Report. Dhaka, Bangladesh.
- Bangladesh Petroleum Corporation (BPC). (2020). Annual Report. Dhaka, Bangladesh.
- Bayer, B., & Marian, A. (2020). Innovative measures for integrating renewable energy in the German medium-voltage grids. *Energy Reports*, 6, 336–342.
- Cairns, R. D., & Smith, J. L. (2019). The Green Paradox, A Hotelling Cul de Sac. *Economics of Energy & Environmental Policy*, 8(2), 161–181.
- Moltke, V., Anja, C. M., Morgan, T., & Töpfer, K. (2003). *Energy subsidies: Lessons learned in assessing their impact and designing policy reforms*. UNEP.
- Nepal, R., & Jamasb, T. (2015). Caught between theory and practice: Government, market and regulatory failure in electricity sector reforms. *Economic Analysis and Policy*, 46, 16–24.

**Open Access** This chapter is licensed under the terms of the Creative Commons Attribution 4.0 International License (<http://creativecommons.org/licenses/by/4.0/>), which permits use, sharing, adaptation, distribution and reproduction in any medium or format, as long as you give appropriate credit to the original author(s) and the source, provide a link to the Creative Commons license and indicate if changes were made.

The images or other third party material in this chapter are included in the chapter's Creative Commons license, unless indicated otherwise in a credit line to the material. If material is not included in the chapter's Creative Commons license and your intended use is not permitted by statutory regulation or exceeds the permitted use, you will need to obtain permission directly from the copyright holder.





---

# 100% Electrification but What Comes Next for Bangladesh? Lessons from Insiders

Nancy Wimmer

---

## Abstract

In 2002 when over 70% of the country's rural population had for generations never known electric light, the most dynamic off-grid electrification program in the world was launched. Its purpose: to provide rural households with Solar Home Systems. Within a decade, Bangladesh was on its way to becoming the world's fastest growing off-grid solar market. This market did not emerge by chance. Here new ideas were at work with both the leadership and the resources to put them into practice: the World Bank as investor; IDCOL, Bangladesh's financial intermediary, as project manager; and rural entrepreneurs as solar service providers. Yet, there is a further remarkable achievement in the Bangladesh energy market. Over 90% of the people in Bangladesh now have access to the electric grid. What role will solar technology play in future? Will the solar market move away from Solar Home Systems towards grid-connected distributed renewable energy systems? What is next for Bangladesh? These are the topics we want to explore in this chapter. This chapter reports hands-on experience from the insiders of the program, and relates their lessons from the past to perspectives for the future.

---

## Keywords

Bangladesh · Rural electrification · Off-grid electrification · Solar technology · Financing

---

N. Wimmer (✉)  
microSOLAR, Vaterstetten, Germany  
e-mail: [nw@microsolar.com](mailto:nw@microsolar.com)

© The Author(s) 2023  
S. Groh et al. (eds.), *Electricity Access, Decarbonization, and Integration of Renewables*, Energiepolitik und Klimaschutz. Energy Policy and Climate Protection, [https://doi.org/10.1007/978-3-658-38215-5\\_3](https://doi.org/10.1007/978-3-658-38215-5_3)



## 1 Introduction: A Project Triggered by Chance

Bangladesh is a fascinating country. In the 1970s, it spawned a groundbreaking microfinance model for the rural poor, which has since been adapted worldwide to serve millions of people with financial services. Where there were no microfinance institutions (MFI) a few decades ago, now there are thousands, serving millions—among them the world’s largest and most successful in Bangladesh: BRAC, ASA International and the Grameen Bank.

30 years later, these MFIs would take part in a bold experiment to bring solar electricity to the hinterland of Bangladesh, where still 70% of its population lived, worked and went to school. In this respect, Bangladesh is no different from other developing countries in Asia and Africa. However, here Bangladesh stands out: Within a decade, rural entrepreneurs had provided nearly a quarter of off-grid rural households, schools and clinics with solar home systems (SHS). A solar market emerged with local suppliers and production. Over 50 solar companies had village service centers in every district of the country. How is this possible? Moreover, could this market have developed all by itself without IDCOL?

In response to this question all experts agree that with 70% of the Bangladesh population living in rural areas—and with more than 65% of the Gross Domestic Product (GDP) generated from there—rural electrification is absolutely needed. The SHS project has in fact now developed into a fully commercialized open market. However, this market could not have developed without IDCOL’s start-up concessional financing, quality standards and leadership. This will be true in other developing countries as well, which can learn much from IDCOL’s successful business model.

It may, however, come as a surprise that what would later become the world’s fastest growing off-grid solar market was in the beginning: a project triggered by chance. Wimmer (2012, 2019) includes more details of this story.

---

## 2 IDCOL’s Journey of Success

IDCOL, the Infrastructure Development Company Limited, came into this SHS Program by accident. IDCOL was established by the Government of Bangladesh (GOB) with a USD 225 million loan from the World Bank. As a 100% state-owned public limited company, IDCOL’s initial function was to on-lend funds to privately sponsored infrastructure projects. Its first project was financing for a 450 MW Independent Power Plant (IPP) on the Meghna River, which it successfully completed on schedule in 2001. However, despite World Bank approval,

IDCOL's CEO had a problem. Dr. Fouzul Khan and his now well-trained management team had no further projects to finance, largely due to the Bank's rigid project eligibility criteria. The result? They were limited to a meager USD 80 million investment out of the USD 225 million World Bank fund. IDCOL was out of a job. There were even rumors about closing down the company when the CEO got a surprise visit.

The World Bank's Task Manager for Bangladesh approached IDCOL with a unique proposal. Would the CEO of the Infrastructure Development Company be interested in managing a pilot project for solar home systems in rural Bangladesh? The systems were on average 50 Wp, the bank's funding for the pilot about USD 25 million and the target, 50,000 installed SHS in five years. It takes little imagination to guess that the former project manager of a 450 MW Power Plant was not amused. Still, he agreed to have a look at a solar home system in a nearby village. What he saw only confirmed his expectations: a clumsy looking system with a cheap car battery, overpriced and unaffordable for the rural population. He refused the bank's offer, but still purchased two solar systems for his family and for a mosque on the off-grid island of Sandwip on the Bay of Bengal.

The arrival of a post card from his family in Sandwip led to a surprising twist in this story. His nieces were overjoyed to have light at the turn of a switch and reliable electricity for their TV. Not enough: a letter from the local mosque told him that villagers were praying for his wellbeing in gratitude for solar electricity. It powered their lights and their microphone for Adhan, the call to prayer without any problems. A call from Dhaka to the Task Manager in Washington D.C. changed everything: Dr. Fouzul Khan would accept the Bank's proposal—but only after having a say in the SHS project's design.

The SHS pilot project was launched in 2002 and met its target in 2005—two and a half years before the target date of five and a half years. One of the main reasons for this unprecedented success was the project's design: It was tailor-made for a low-income population in rural Bangladesh. Its finance model, for example, was a blending of microfinance and project finance, both of which were loans given in local currency with little or no collateral. This allowed even low-income customers to own an expensive solar home system through affordable monthly installments.

With extended funding from the World Bank, SHS installations continued unabated—further accelerated by unexpected tailwinds. While the prices for kerosene continued to rise, solar panel prices were coming down—a veritable windfall for a SHS project. To top it all off, LED lights were introduced to the solar market. Smaller, more affordable 30 Wp solar systems now allowed the same advantages

as a 50 Wp system. The rural market for solar home systems was booming. By 2013, solar entrepreneurs were installing 65,000 solar home systems a month.

Nevertheless, while tailwinds propelled market growth to ever new heights in 2013, strong headwinds were forming to soon bring it to a halt. The Bangladesh government started giving away free solar home systems under its social safety network program for the poor. It accelerated extension of the electric grid into rural areas. A private unregulated SHS market emerged when electronics traders in old Dhaka began marketing cheap Chinese solar systems to rural customers. As a result, the installation of the six million solar home systems envisioned by IDCOL did not materialize. Solar customers defaulted on their loans. Solar companies were unable to repay their loans to IDCOL. The money ‘got stuck’. And IDCOL was hard put to find solutions to these problems.

There is however yet another headwind to be mentioned, claims Dr. Khan. “Some kind of complacency drifted into IDCOL. Success was so great. Everybody was in a celebrating mood and not thinking about this. However, the hallmark of IDCOL has always been that it was proactive rather than reactive to events. The success of the SHS project was a collective effort. The World Bank, IDCOL, the rural entrepreneurs, academics—all contributed to its success. But it was IDCOL that was always in the lead. This is what is meant by public entrepreneurship. IDCOL must become more proactive and place itself in the forefront again.”

What can we learn from Dr. Khan’s story. First and foremost: that seeing is believing. While he did in fact see the solar home system, he did not believe in its value for the rural population until literally seeing it through the eyes of his family on an off-grid island. Demonstration is fundamental to rural business. In addition, I can confirm from my years of experience with solar engineers in rural Bangladesh how hard it was to explain to people that energy from the sun could light up their houses at night.

We also learned about innovation. Innovative breakthroughs often come from combining existing methods in new ways and then testing them. The strength of IDCOL’s innovative financial model was the blending of microfinance and project finance. In addition, it was designed in a way that had to be tested by trial and error and continuous iteration. This is something to remember when building a rural market.

“Bangladesh is unique in having so many successful microfinance organizations. But you chose not to subsidize them or to subsidize their product, but to incentivize private enterprise to develop a solar market. Why was that your choice?” Dr. Khan: “Well you see, from the beginning our goal was to commercialize solar home systems. So our dream was that you could buy a radio from the rural market. However,

to achieve this we would have to break the barriers in the market and our answer was to give rural companies two types of subsidy: a capital buy down grant to lower customers' installment payments; and a subsidy to the rural companies for institution building. But you see, these were all gradually reduced and eliminated."

Dr. Khan further explained that the purpose of the subsidies was from the start to strengthen private enterprise to create a solar market. This was also the purpose of IDCOL's concessional loans. As the market evolved, the interest rates increased, so that the rural companies and the market could later stand on their own without help from IDCOL. This was also the reason for inviting large, private companies like Singer, Bangladesh to participate in the SHS project. Unfortunately, they did not find this business worthwhile and left the program. It's a fact: rural business is full of risks and takes time to develop.

---

### 3 IDCOL's Journey into the Future

Having looked at the past, we now turn to discuss IDCOL's journey into the future. Monir Islam is the company's first accountant and its present Chief Financial Officer (CFO): "If you really want to understand this level of success, you need to first understand the context." When the SHS project was launched, access to electricity was less than 40%, so solar power was urgently needed in rural Bangladesh. The challenge was to create awareness for a new and exotic technology by showing people that sunlight can really produce electricity. This was hard going in the beginning. However, from that level of awareness, Bangladesh is now known as a solar nation.

To better understand IDCOL's past success you must also see how it developed an ecosystem for this market. In the beginning, there were hardly any solar manufacturers and suppliers and solar equipment had to be imported. Therefore, IDCOL developed local capacity with now over 200 solar manufacturers and suppliers' that work and manufacture in Bangladesh. Then there was the challenge of supporting the partner organizations to demonstrate, deliver and service this new technology in the villages. In the end, finding workable solutions to all these problems created IDCOL's past success.

"And we learned," adds Monir. "Still there were interventions beyond our control. Grid connectivity, for example. Beginning in 2014 about 300,000 connections were being made each month. But a year beforehand we hardly knew about this plan. So there was a clear lack of coordination and that was a big lesson for us, which will probably help us in future."

In addition, the future looks promising according to IDCOL's Deputy CEO. Its past success also motivated the company to take up other renewable energy interventions. It has supported the installation of 26 solar minigrad projects and 1514 solar irrigation pumps. A successful biogas and bio fertilizer program has been launched. In only a few years, 57,000 domestic biogas plants are now supplying clean energy for cooking and lighting across rural Bangladesh. Still experiments but promising, are biomass and biogas-based electricity projects for commercial enterprises in the poultry industry.

IDCOL's main focus at present is on solar rooftop projects, in particular in the industrial sector. Surveys show that there is a potential of more than 500 megawatts alone in the garments and textile manufacturing industries. IDCOL has begun implementing these projects with a target of 300 megawatt generation capacity on industrial rooftops by 2023. In addition, although the COVID 19 pandemic seriously slowed down progress, IDCOL's active pipeline promises more business in the solar sector in future.

As impressive as these achievements are, no national solar energy program can succeed at length without government policy. The good news: IDCOL's past success in the solar sector motivated the Bangladesh government to introduce various policy and strategy documents in support of solar power. The problem is they come from as many different government agencies and lack coordination. There is, for example, the Master Plan, the Bangladesh Delta Plan, the Eight & Five Year Plan, and now under the banner of the G20 Group, the Multi-Climate Prosperity Plan for the next two decades.

All of these strategic documents promote the implementation of different renewable energy projects with different targets in the coming years. IDCOL is forging strategic plans to be part of the targets set by the Bangladesh government. The government has already transferred a number of grid-connected solar projects to the private sector. IDCOL has financed one project so far with a capacity of 10 megawatt electricity from a solar park. Still, more projects are in the pipeline, which IDCOL plans to finance.

My response to Monir focused on rural business. "If Bangladesh is to live up to its goal of becoming a solar nation, certainly it will have to support solar projects in urban areas as well. But we know rural business to be far more challenging. Can you please tell us what rural energy projects are moving fastest and where progress is slow and difficult?"

Monir's response comes as little surprise: "the rooftop projects are going great. But solar powered irrigation and minigrad projects remain the most challenging for two reasons: extension of the electric grid has limited the expansion of minigrad projects to off-grid islands as defined by the government. And the

solar irrigation pump projects still require a subsidy to compete with the diesel-run pumps. But we remain optimistic. We have successfully implemented more than 1500 pumps already and are discussing with development partners how we can take this project to the next level.”

---

## **4 The Private Sector Perspective**

The private sector perspective is represented by the Managing Director of Rahimafrooz Renewable Energy, Mr. Munawar Moin. The solar sector has experienced dramatic growth during the past decade with 22 solar battery manufacturers, 83 solar LED light manufacturers, 9 solar panel manufacturers and more.

Munawar reports on the role of the private sector in demonstrating solar technology. This began as early as the mid-1990s, but if you look at the solar home system, just demonstrating that this technology actually works was done by private players. This moved on to solar powered irrigation pumps and even rooftops. Munawar remembers when potential solar rooftop owners simply would not believe that energy could come from the sun and get into the grid and then light up the building. Therefore, the key role played by the private sector was to demonstrate solar technology works, is efficient and reliable.

After a decade of rapid market growth, solar technology has now become a purely commercial open market. Six million rural households are enjoying solar electricity and need replacement products and service. Even urban customers are investing in solar systems. Everyone knows that last mile electricity delivery by the grid will be inconsistent in the near future. So solar systems have become backup power systems for reliable power during breakdowns. Five to ten thousand solar systems are sold every month for this reason.

This is all a continuation of the SHS project. The challenge is now to take this market to the next level of growth. It could be rooftops and irrigation pumps. Alternatively, it could be productive applications like milk chiller storage and rice driers. Whatever you may call it, renewable energy technology will really ramp up based on how directly we can link it to productive use. This is the challenge we face: to come up with solar solutions which educate users on their benefits. The solar powered irrigation pump is a good example of productive use for farmers. Solar rooftop owners now see clearly how they benefit in terms of cost and sustainability from green energy.

But these benefits must also be clearly demonstrated to be understood. Why? Because whenever you try to do something new with renewable energy, its opponents grill you. You understand how efficient and cost effective solar power is. Still when you look at conventional energy, it is getting all the subsidies. You understand the significant inefficiencies of the electric grid, but they are simply overlooked. Renewable energy is not an option.

Munawar is however still optimistic that the present dilemma will inspire the solar sector to ensure that new technologies are demonstrated, piloted and are commercially viable. In addition, by this he means all players—from consumers, financiers and regulators to the manufacturers and suppliers. All should be aligned and part of this process to show the benefits of renewable technology. So in rural Bangladesh, where 70% of the population lives and much of the productivity—up to 65% GDP—comes from there, any renewable energy solution that helps to improve agro output, livestock output, fisheries output, small medium enterprise output is vital to Bangladesh's future growth. These solutions are in fact already becoming feasible.

IDCOL is today the only finance institution specialized in renewables. However, when talking about future growth for renewables, this will require hundreds of millions of dollars' worth of financing in the sector. This is what the financial sector has to learn from IDCOL: as IDCOL grows the solar market, the whole finance sector must also grow in this direction to support renewable energy technologies with productive use. In addition, because IDCOL is the only loan-specialized financing institution for renewables, it has demonstrated to the world what this can mean when developing a solar market. But now, if private businesses want to scale up, they will need many more financial institutions for the simple reason that IDCOL alone cannot be funding everything.

Let us say we need three hundred thousand irrigation pumps to be rolled out right now. Alternatively, we need two to three gigahertz of solar rooftops. IDCOL alone cannot fund these projects. Maybe it will do 50%. However, who will do the rest? Other financial institutions will also have to come up. The Bangladesh Bank will have to play a much more proactive role. Commercial banks with networks all over the country can learn from IDCOL and see how they can finance renewables. The Bangladesh Bank has introduced the Green Funds, but that policy has not yet been as effective as IDCOL's support for renewables to the last mile. This is what will move the sector forward.

## 5 What Africa can Learn from Bangladesh

In this section, we address the issue of transferability of lessons, in particular what lessons from Bangladesh are relevant to Sub-Saharan Africa, where Pay-As-You-Go (PayG) companies are rapidly expanding their solar business. Sanjoy Sanal, an entrepreneur from the Indian Institute of Management in Calcutta (India) summarizes the three things he believes IDCOL has to teach Africa: first of all at the policy level. IDCOL's policy ensured that public finance reached the local MFIs and that microfinance reached the rural households. The second lesson focuses more on private enterprise, particularly important for Bangladesh business people. IDCOL's partner organizations (POs) were both lenders to rural households and solar suppliers. As a result, dozens of businesses outside the program emerged as the solar market matured: 22 battery and 83 LED manufacturers in total. Bangladesh business people should therefore be thinking about expanding their business to Africa.

Thirdly, and most important: African countries should learn from Bangladesh that international development aid and international policy advice go only so far to make a country prosperous. Rather, it is the ability of people like IDCOL's CEO to be able to sit across the table with a World Bank professional and say: this works in this way in my country and I will experiment and pilot this SHS project in my own way.

In what follows, Sanjoy breaks down each of these points to explain them in detail. With regard to the policy issues on the finance side, he describes his frustration with international conferences held in big cities like Amsterdam and Vienna every year—and which every year seem to try to reinvent the wheel with regard to finance for developing countries. Why do none of them ever talk about Bangladesh? After all, it is the only country in the world that succeeded in electrifying a large percentage of rural households. 25 million people are now using solar home systems. Where in the world has this happened?

What can be learned from Bangladesh is how IDCOL made local currency debt available at a reasonable price to its partner organizations, which in turn made it reasonable for rural households. The POs borrow in local currency from IDCOL at 6% interest with a loan tenor of five to seven years, and then on-lend to their solar customers at 12% interest over three years. That's project finance meeting microfinance.

The second lesson the SHS project has to teach is how it ensured quality products. Rural households are hesitant to finance solar systems because they often fail. In contrast, IDCOL set up an entire quality infrastructure from quality



standards to certification to testing solar home systems in the field by IDCOL inspectors.

Last, not least, the third lesson stresses the importance of the partner organizations for the success of the SHS project. They had the ability to go to people's houses to provide customer service and collect the monthly installments. More than this, they were given the incentives to do the job. This is, as Dr. Khan pointed out, a results-based financing program.

So in conclusion, even after working for seven years in Africa, Sanjoy cannot think of any African nation being able to replicate and adapt a decentralized renewable energy program without these building blocks. You can say Pay-as-You-Go companies in Africa are doing the same thing and that is true. These solar companies are lending to households. However, because they do not have domestic local currency debt financing, they have to put up these very complicated structures overseas—like raising money off-balance sheet and sending it to Africa. This leads to three problems.

Number one: there will never be those 22 battery manufacturers and 83 LED manufacturers in Africa. Second, it is very risky if one of these companies fails. Third, it is very expensive if it is foreign currency debt subject to foreign currency fluctuations. This means maybe a poor African farmer has to then pay more for electricity. Is that fair? Is it fair to subject a poor farmer to the vagaries of the market?

Sanjoy concludes by adding that businesses in Bangladesh need to think about moving out and thinking about Africa. Monir Islam said earlier today that all the component manufacturers really emerged in Bangladesh. However, where are these component manufacturers in Africa when Rwanda is setting up its Made in Rwanda Policy and inviting foreign direct investment? Companies from the Netherlands are investing there. Bangladesh business people have to ask themselves why we could not see that opportunity.

Therefore, the lesson is: it is important for Bangladesh to say to the world that we did this thing, that today we are a middle-income country—, and that the time has come for us to be confident, to go to the world, and to tell our story.

My first response to Sanjoy came from my own experience as presenter at international conferences: Although I was invited to speak about the SHS market in Bangladesh, I was introduced as 'now Nancy Wimmer will tell us about India'. Bangladesh is somehow not on the map—just one reason I wrote two books on its astonishing success in developing a rural market for solar home systems (Wimmer, 2012, 2019). Another is why this country has very good reason to be proud: the development of a solar market in rural Bangladesh proved to the world that

the impetus for market development can come from within a developing country—driven by local entrepreneurs under IDCOL’s leadership.

There are indeed many good ideas to learn from. Of particular importance was how solar companies in Kenya and Tanzania are dependent on foreign capital for funding. In contrast to the POs in Bangladesh which borrow from IDCOL in local currency, these PayGo companies must either absorb foreign currency fluctuations or pass them on to their customers—like the poor farmer who must now pay more for electricity. Bangladesh can in turn learn how new technologies like PayGo can drive the solar market. IDCOL recognized too late, how innovative tech companies like SOLshare could take the solar home system market to the next level.

---

## **6 What Comes Next for Bangladesh?**

In this final section, we discuss the future, after having reached almost 100% electrification for Bangladesh. What is next for the solar energy sector? Dr. Khan explains that two things are most important: electricity access and the quality of the electricity provided. We have done quite well in terms of grid extension, which includes off-grid solar home systems. What is next is the quality of the electricity we are getting: how many interruptions per day for how many hours, what voltage is right, for example.

A third issue is sustainability. Bangladesh’s focus remains on fossil fuel based energy. This is unfortunate, because in the long run this is not sustainable. However, you know, people make tons of money through energy imports. Therefore, it is a balancing act between fossil fuels and solar energy for the sake of sustainability. We have to first fill in the gaps with renewables, because although now 96% of Bangladesh households are officially grid-connected, there are many gaps in the quality we have to plug up. We must also move up the energy ladder from DC electricity to great quality electricity provided by rooftop solar, irrigation pumps and especially to promote income generating activities through electricity.

Dr. Khan also stresses his strong belief in institutions. He has good reason to do so. There were two assassination attempts to shut the company down: the first by Bangladesh’s Finance Ministry because IDCOL was unable to utilize the entire World Bank fund for infrastructure projects. Fortunately, the CEO could prevent the worst by explaining the problem in depth to the Finance Minister after which the Minister contributed BDT 50 Crore (500 hundred million) to IDCOL to increase its equity capital!

The second assassination attempt was by the World Bank itself. Following the closure of the Bank's fund, a project completion mission visited IDCOL. The Task Manager proposed to close down IDCOL and divert the reflows to the Investment Promotion and Financing Facility (IPFF), a new project he was developing. This attempt failed. IDCOL was a wholly government-owned company. Only the government could decide its fate.

Ironically, the third near-death experience was in part a result of IDCOL's success. The SHS pilot project met its target two and a half years before the target date of five and a half years and then ran out of grant funding. Rapid growth was in this sense a disaster for the SHS project. Luckily, the CEO was able to secure grant funding for the project after a meeting with the German Ministry for Economic Development in Berlin: again by chance.

In contrast, Monir Islam, IDCOL's Deputy CEO goes straight to the immediate challenge confronting IDCOL. But first the good news: inspired by the SHS project's success, the Bangladesh government (GOB) set a target of ten percent of the total generation capacity to come from renewable energy sources by 2021.

"But if we can achieve this 10% target in even the next five years," claims Monir—and this is the challenge—"this would mean around 3000 megawatt coming from renewable energy. Our achievement so far is about 3.5%. Therefore, we have a long way to go. The good thing is that all the right policies are in place. We have targets and pathways set by the GOB. We now know about the potential of unexplored renewable energy sources, like offshore wind energy and floating solar projects. We have done assessments and we have the expertise. So yes, I am hopeful and optimistic that we can reach the GOB's target for renewable energy. There will be more success stories coming up in the near future."

Munawar Moin summarizes the experience from the private sector in the following way: Success in Bangladesh mainly happens because there is a plurality of drivers. "You know multiple people in different areas all doing their job with a lot of commitment and heart," explains Munawar. "And I think we see this in the solar sector right now. Despite its difficulties, this is happening and this is what's going to happen at least in the foreseeable future".

Still, institutional support for the continued growth of the renewable energy sector is crucial. Even in very recent discussions with policy makers, the private sector has been telling them what it believes is needed: a single ministry similar to the Ministry for Renewable Energy in India, which is empowered with a budget program and resources to accelerate market development for renewables. As an added incentive, Bangladesh's honourable Prime Minister, committed

Bangladesh to 100% renewables by 2050 at a climate conference in Morocco in 2016.

True, the progress in rooftop solar is encouraging and will continue because of its commercial viability and the net metering policy. However, the main thing is we need a paradigm shift in thinking at the policy level. If we think that progress in the renewables sector will happen only by an increase in megawatts, solar power plants and similar projects, we are thinking very much like in the past. What has to happen in future—and this has already begun—is more distributed renewable energy systems, many grid-connected, for productive use.

In addition, this again needs demonstration, since energy cannot be seen by itself. It needs to be connected to productive use. An example: over one million vehicles are transporting anywhere between 8 to 10 million people every day and are still being charged with grid electricity. It is a huge business, employing 1.5 million people. Now just imagine this same business if these vehicles were solar powered or being charged from solar hybrid charging stations. Here you see a whole system, which is fully connected with enormous potential for renewables.

With a clear vision for the future, Munawar believes: at the end of the day, we will have more energy efficient and sustainable energy systems, which lead to more economic and social upliftment. This is already happening with solar powered irrigation pumps. However, its future success depends on what IDCOL alone cannot do. The government must come up with a feasible proposition to support the continued acceleration of the renewable energy sector, where “we all collectively work to make this vision reality: 100% renewables by 2050”.

According to Sanjoy Sanal, the primary issue in Bangladesh in the next decade will be climate adaptation and resilience. Bangladesh must be thinking about how to incorporate renewable energy thinking into climate resolution issues, for example with productive use and electric vehicles. In view of the dim forecasts for extreme climate change in the delta in future, this cannot wait.

The second thing Sanjoy wants to see continue is innovation. Bangladesh should continue to innovate on the infrastructure it has built. The company, SOLshare, with its innovative peer-to-peer solar trading model is a good example. Village milling or rice husking centers run by renewable energy, another. Opportunities for innovation abound, including the Green Climate Fund (GCF). IDCOL has been accredited and is mobilizing funds from the GCF for climate adaptation and climate mitigation projects. It will now be easier for the renewable energy sector to achieve its 10% target, since it can source funding not only from the government or its development partners. In future climate mitigation projects can be funded through the GCF.

Following two decades of development in the renewable energy sector, Bangladesh is now perfectly positioned to move onto the next level. Yet, whether strong tailwinds will come from funds like the GCF or increased institutional support from the Bangladesh government—or both—is not yet certain. Bangladesh's renewable energy sector has good reason to be optimistic. It not only demonstrated that the development of a rural market for solar power is doable and profitable. It proved to the world that this market development could come from within a developing country—driven by local entrepreneurial companies.

---

## References

- Wimmer, N. (2012). *Green energy for a billion poor: How Grameen Shakti created a winning model for social business*. MCRE-Verl.
- Wimmer, N. (2019). *The Marketmakers: Solar for the Hinterland of Bangladesh*. CreateSpace Independent Publishing Platform.

**Open Access** This chapter is licensed under the terms of the Creative Commons Attribution 4.0 International License (<http://creativecommons.org/licenses/by/4.0/>), which permits use, sharing, adaptation, distribution and reproduction in any medium or format, as long as you give appropriate credit to the original author(s) and the source, provide a link to the Creative Commons license and indicate if changes were made.

The images or other third party material in this chapter are included in the chapter's Creative Commons license, unless indicated otherwise in a credit line to the material. If material is not included in the chapter's Creative Commons license and your intended use is not permitted by statutory regulation or exceeds the permitted use, you will need to obtain permission directly from the copyright holder.





# Policy Options While Increasing Share of Renewable Energy: Technology Choices for Peaking Power in the Context of Bangladesh

Riya Roy, Abdullah Al Jubayer, Kazi Sadman Sakib,  
Najmus Sakib, Avijit Saha, M. Rezwan Khan  
and M. Shahedul Alam

---

R. Roy (✉) · A. Al Jubayer · K. S. Sakib · N. Sakib  
Electrical and Electronic Engineering, United International University,  
Dhaka, Bangladesh  
e-mail: [rroy171019@bseee.uui.ac.bd](mailto:rroy171019@bseee.uui.ac.bd)

A. Al Jubayer  
e-mail: [ajubayer171028@bseee.uui.ac.bd](mailto:ajubayer171028@bseee.uui.ac.bd)

K. S. Sakib  
e-mail: [ksakib171085@bseee.uui.ac.bd](mailto:ksakib171085@bseee.uui.ac.bd)

N. Sakib  
e-mail: [nsakib153027@bseee.uui.ac.bd](mailto:nsakib153027@bseee.uui.ac.bd)

A. Saha · M. R. Khan  
School of Science and Engineering, United International University,  
Dhaka, Bangladesh  
e-mail: [avijit@eee.uui.ac.bd](mailto:avijit@eee.uui.ac.bd)

M. R. Khan  
e-mail: [rezwanm@uui.ac.bd](mailto:rezwanm@uui.ac.bd)

M. S. Alam  
School of Business and Economics, North South University, Dhaka, Bangladesh  
e-mail: [shahed.muhammad@gmail.com](mailto:shahed.muhammad@gmail.com)

© The Author(s) 2023

S. Groh et al. (eds.), *Electricity Access, Decarbonization, and Integration of Renewables*, Energiepolitik und Klimaschutz. Energy Policy and Climate Protection, [https://doi.org/10.1007/978-3-658-38215-5\\_4](https://doi.org/10.1007/978-3-658-38215-5_4)

---

**Abstract**

In Bangladesh, the peaking power plants that serve the peak time loads use conventional fossil fuels for power generation. These power stations remain idle for a good part of their operating life, which therefore results in a high overhead cost. Continuous integration of renewables into the grid is increasing the dependency on these, so far, feasibility of no other less-expensive options has been studied. In this context, this paper aims to analyze the financial feasibility of different alternative options. Three possible options were analyzed and the levelized cost of energy (LCOE) was compared with that of conventional peaking power plants. It was found that Battery-based storage systems are not financially feasible at this moment, while the nation's lone hydro power plant promises financial feasibility if solar PV driven pumped hydro storage is implemented. We also report that if the nation continues to add solar PV power stations even with costly peaking power plants using traditional fuels, this hybrid option was counter intuitively found to be financially feasible.

---

**Keywords**

Peaking power · Renewable energy · Solar power · Energy storage system · Grid carbon footprint

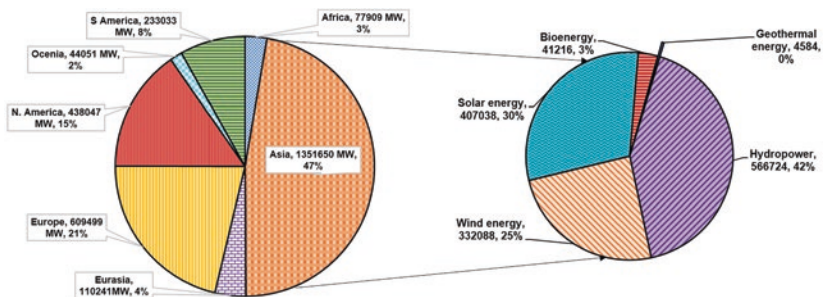
---

## 1 Introduction

World electricity production industry is predominantly occupied by conventional fossil fuel-based power plants. Since about 1850, the world has commercially depended on conventionally produced fossil fuels such as coal, oil, natural gas, etc. which supply about 75% of energy today (Karim et al., 2018). Total electricity generation all over the world was 25,849.92 TWh in 2020 (Ritchie & Roser, 2020) and the share of renewables is increasing every year as the world leaders are committed to reduce the use of fossil fuels for curbing the detrimental effects of uncontrolled use of fossil fuels especially in producing electricity. The world's dependence on renewable energy sources for electricity generation has increased by more than 10% per year since the late 1970s (Karim et al., 2018). The usage of renewable sources in 2012 contributed 13.2% of global supply, hit 22% of global power production in 2013 and was expected to hit 26% by 2020, which is more than current combined demand from China, India, and Brazil (IEA, 2015). According to Ritchie, in 2020, renewable energy sources accounted for 28.98%

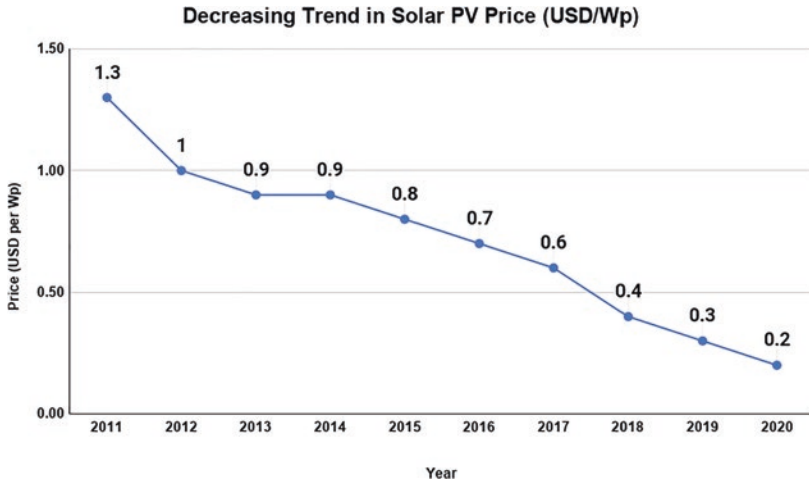
of global electricity, which was higher than forecasted data (Ritchie, 2021). Sweden, Norway, France, Paraguay, Iceland, Nepal, Bhutan, Canada, Ethiopia, Finland, Brazil, for example, get over 90% of their energy from nuclear or renewable sources (Ritchie & Roser, 2020). According to the report “Renewable Energy Capacity Statistics 2021” by IRENA, global renewable energy generation capacity is around 2,799,094 MW (IRENA, 2021). In Fig. 1, we can observe Asia accounts for approximately 46% of total installed capacity. However, it is paramount for the world to make this transition to increasing share of renewable sources without compromising reliability because supply instability will interfere with proper economic performance (Karim et al., 2018).

Bangladesh is also focusing on integrating renewable based power generation facilities into the national power grid. According to Sustainable Renewable Energy Development Authority (SREDA) in Bangladesh, total contribution from renewable energy is 3.24% of total installed capacity. Bangladesh mostly uses hydropower (230 MWp), solar PV (195.01 MWp is connected to the national grid while another 565.16 MWp capacity is in the pipeline) and few wind energy-based projects with a total capacity of 74.9 MWp (SREDA, 2021). In recent times, solar PV systems have been added to a greater capacity than other sources. This proliferation is mainly fueled by the global decreasing trend in the price of energy from solar PV systems. According to IEA, the price of grid-tied solar PV decreased from 1.3 USD/Wp (2011) to 0.2 USD/Wp (2020) shown in Fig. 2. In the near future, the price is expected to fall further. This indicates that there will be more opportunities to build new solar plants at a lower price leading to even lower per unit cost of produced solar energy (IEA, 2020a).



**Fig. 1** Grid connected RE capacity in the world, with technology mix shown for Asia. (Source: (IRENA, 2021))

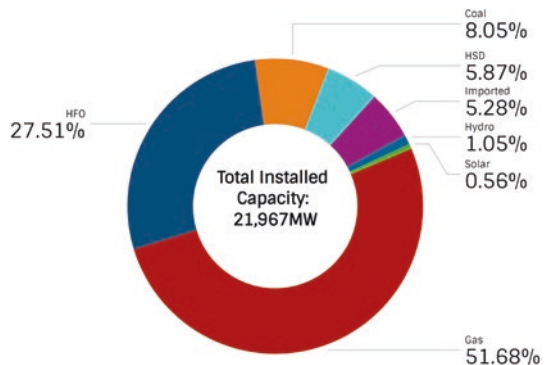




**Fig. 2** Decreasing trend in solar PV price (USD/Wp). (Source: (IEA, 2020a))

However, Bangladesh is still heavily dependent on fossil fuel, more specifically on its natural gas resources, for power generation. Figure 3 shows the fuel mix of power generation in Bangladesh. Although, natural gas is the least expensive fuel, its reserve is depleting at a faster rate. If new gas reserves are not explored, it is anticipated that Bangladesh might experience a price hike in gas price as the dependency on imported LNG will increase. In addition to this, the share of other fuels like HFO and coal in power generation is bound to increase. HFO is an imported fuel and we have used locally mined coal so far. Although

**Fig. 3** Installed capacity (in MW) of BPDB power plant by fuel type. (Source: (BPDB, 2021))



the quality of the coal is pretty good, the depth of the coal mines and the soft alluvial soil of Bangladesh makes the coal extraction more expensive compared to the price of coal in the international market (Barapukuria Coal Mining Company Limited, 2021) Bangladesh presently imports about 5% of its power from India, which may also go up in future. The decreasing use of natural gas and increasing use of coal, HFO, LNG, nuclear and renewables have their own concomitant implications.

Meeting time-varying demand, especially during peak periods, is a significant challenge for electric utilities. Small capacity power stations, such as gas or HFO power plants, are commonly used to mitigate the peak demand. Diesel generators are still widely used in isolated power systems to satisfy peak demand (Uddin et al., 2018). However, the cost of operation and maintenance (O&M) for these power plants is high (Chua et al., 2013). Thus, peak load shaving has become an important issue. Peak load shaving is a technique for flattening the load curve by lowering the peak load and moving it to lower load times (Nourai et al., 2008).

Different strategies for peak load shaving have been followed all over the world, such as, Tariff Incentives (TI) and Demand Side Load Management (DSM) (Uddin et al., 2018). It is a common practice to change the tariff during peak and off-peak hours on a daily basis. In some countries, the tariff varies with seasonal demand as well to influence usage patterns of the consumers (Energy Information Administration – EIA, 2021). Since the 1980s, one of the most promising methods for mitigating peaks has been Demand Side Management (DSM) (Gellings et al., 1986). Most research, however, focused on DSM techniques in developed countries, as making DSM more successful necessitates the use of latest technologies like smart grids, which include smart metering systems (Lu, Hong, and Zhang, 2018). Battery technologies in households are also included in some of the DSM schemes. With the development of IoT, the consumers are also using smart systems (e.g., smart home management) to reduce their peak load and energy bill. Companies like Tesla, Duracell, LG Chem, Moixa, Powervault, Solax, Sonnen, VARTA are installing domestic BESS in UK (Department for Business, Energy & Industrial Strategy, 2020). Tesla's "Powerwall" is intended for daily cycling such as for load shifting. Tesla revealed in October 2016 that nearly 300 MWh of Tesla batteries had been implemented in 18 countries. Tesla reported in April 2020 that it had deployed its 100,000th Powerwall. Powerpack is designed for industrial and electric utility grids and has lowered utility bills by 20% in some cases (Wikipedia Contributors, 2021a). To the best of authors' knowledge, no study has been reported that assessed the feasibility of different load shaving techniques and possible options as an alternative to expensive fossil fuel based peaking power plants in the context of Bangladesh.

This study has therefore been conducted to address the high operating cost associated with fossil fuel based peaking power plants by assessing the financial feasibility of three different energy generation options to meet the peak loads. To justify whether the options are feasible or not, the levelized cost of energy from these options are compared to the cost of fossil fuel based peaking power plants.

---

## 2 Methodology

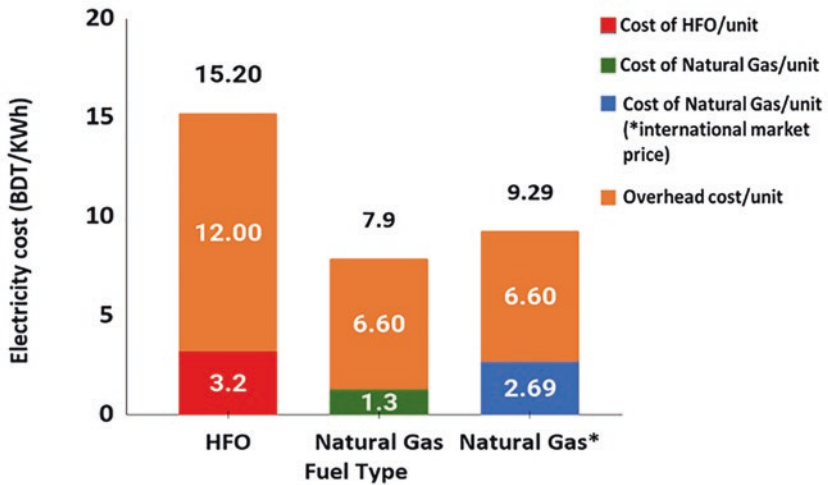
According to the report “Renewable Energy Capacity Statistics 2021” by International Renewable Energy Agency (IRENA), global renewable energy generation capacity is around 2,799,094 MW (IRENA, 2021). In Fig. 1, we can observe Asia accounts for approximately 46% of total installed capacity. Bangladesh mostly uses hydropower (230 MWp), solar PV (136.44 MWp is connected to the national grid while another 565.16 MWp capacity is in the pipeline) and few wind energy-based projects with a total capacity of 74.9 MWp (SREDA, 2020). This study has been performed to suggest feasible alternatives to fossil fuel based peaking power plants that are not only expensive but also pose deleterious impacts on environment. To satisfy the objectives of the study, following tasks have been accomplished:

- Analyze the fuel type and LCOE of existing peaking power plants in Bangladesh
- Propose the system layout for three different alternative options to meet the peak loads
- Evaluate the LCOE of the proposed systems
- Compare the LCOE of the proposed systems with that of existing peaking power plants
- Suggest the feasible options so that policy makers can take immediate actions

---

## 3 Current Scenario of the Peaking Power Plants in Bangladesh

All the existing peaking power plants are fossil fuel based, except the Kaptai hydro project. The cost of energy varies by a big margin, depending on the type of fuel used, hours of use per year and overall maintenance cost (the cost breakdown can be found in Fig. 4). As per data available on the BPDB website some of the peaking power plants, used for very small hours (2% plant factor), have



**Fig. 4** Per unit electricity generation cost for different fuel based peaking power plants. (Source: Power Grid Company of Bangladesh Limited (2021))

an energy cost of Tk. 41.60/kWh (for HFO) and Tk. 72.29/KWh (for HSD). The average energy cost of Bangladesh Power Development board (BPDB), including the IPP peaking power plants, is Tk. 17.50/kWh.

BPDB operates 14 peaking power units, one of which is natural gas-fired, three are HSD-fired, and the remaining ten are HFO-fired. Additionally, there are Twelve Quick Rental Power Plants (QRPP) and Nine Rental Power Plants (RPP) with a combined capacity of 1395.89 MW. Between 2014 and 2017, most QRPPs were extended for a further 3–5 years following their initial retirement phase.

#### 4 Possible Technology Options in Bangladesh as Alternative to Conventional Peaking Power Plants

Keeping in mind the technical and financial issues associated with the conventional fossil fuel based peaking power plants; we have proposed three technology options in this paper:

1. Storage battery to store energy during the daytime from grid power and to deliver during the peak hours.
2. Limited pumped hydro facility to pump water from the downstream of Kaptai hydro plant to the reservoir using solar power during the daytime and then discharging the water during the peak hours.
3. Solar PV-HFO hybrid power plants capable of supplying peak load in the evening.

In the following sections, we present an analysis of the three cases mentioned above. The LCOE from these options are then compared with the conventional fossil fuel based peaking power plants. To calculate LCOE we followed the following formula:

$$C_o = C_{in}/\eta + (I_{cap} + \Sigma D_i + M)/E_{out} \quad (1)$$

where,

$C_o$  is the cost of output energy per kWh

$C_{in}$  is the cost of input energy per kWh

$\eta$  is the system efficiency

$I_{cap}$  is the annual interest on the capital investment

$D_i$  is the annual depreciation of the  $i$ th ( $i = 1, 2, 3, \dots$  etc.) capital investment

$M$  is the annual operation and maintenance cost

$E_{out}$  is the expected energy output from the system.

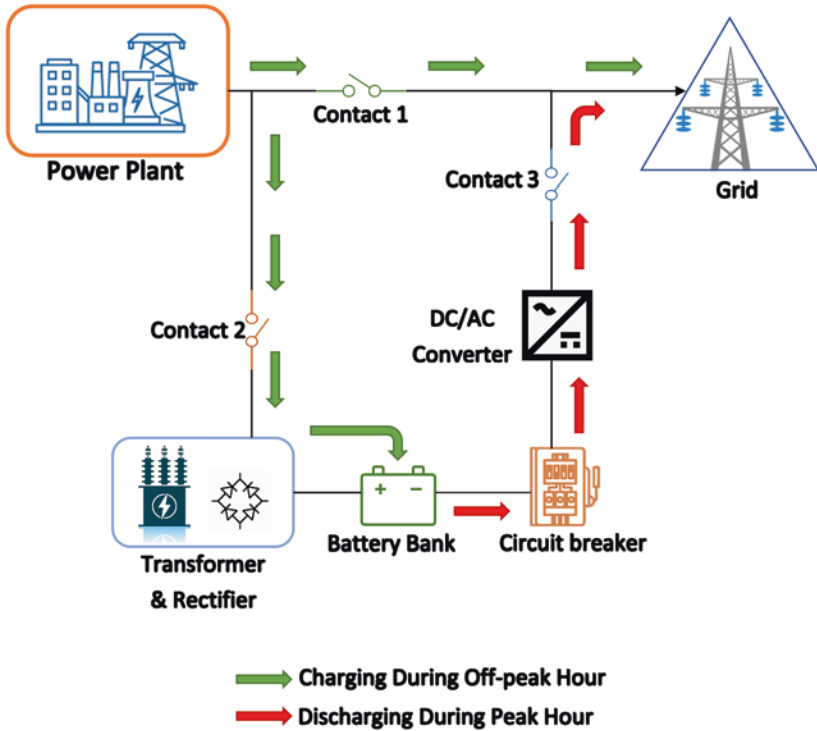
## 4.1 Case 1: Battery Storage

We would like to consider two battery storage options to replace the conventional fossil fuel based peaking power plants. One using Lithium-Ion battery and the other using the more conventional Lead Acid batteries. The basic structure of such a system is shown in Fig. 5.

As shown in the Fig. 5, the batteries are charged during the off-peak hours when the load demand is minimum, and the stored energy is delivered to the grid during the peak hours.

### 4.1.1 Lithium-Ion Battery Storage

The assumptions we considered for energy cost estimation in a Lithium-Ion battery storage system is given below



**Fig. 5** Schematic diagram for the proposed battery energy storage system. (Source: Own depiction)

Cost of battery/kWh = BDT 20,820

Maximum depth of discharge of the battery = 90%

Cost of inverter/kW = BDT 6940 (including charging unit)

Inverter efficiency = 98%

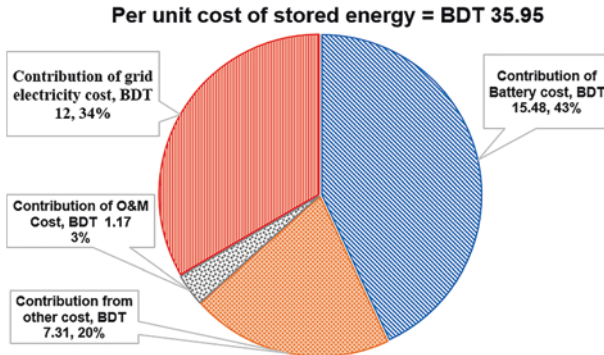
Expected battery life = 7 yrs

Expected inverter life = 5 yrs

Interest rate = 9%

Battery efficiency = 85%

The stored energy cost, as calculated using the above data, comes out to be BDT 35.95/kWh. The cost breakdown in percentage of the energy cost is shown in



**Fig. 6** Cost per kWh and the percentage cost breakdown for Lithium-Ion battery-based energy storage. (Source: Own depiction)

the Fig. 6. If we compare to the average peaking power plant energy cost of Tk. 17.50, it is higher by about 100% and economically not a viable alternative.

#### 4.1.2 Lead Acid Battery Storage

Although Lithium-Ion batteries are getting more popular in recent years due to various improved performance indices (like depth of discharge, efficiency, longevity, weight/kWh storage etc.), lead acid batteries are still quite popular for their low cost. Our assumptions for the cost analysis of the lead acid batteries are given below.

Cost of battery/kWh = BDT. 14,720

Maximum depth of discharge of the battery = 70%

Battery efficiency = 80%

Expected battery life = 5 yrs

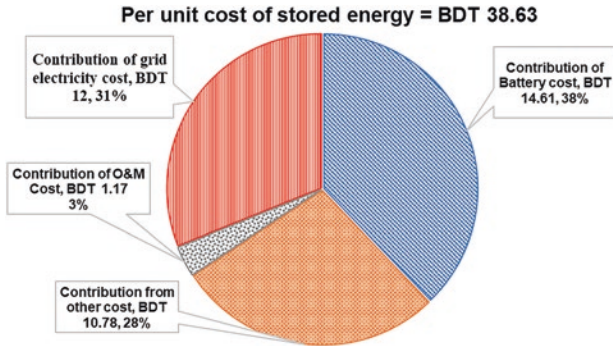
Cost of inverter/kW = BDT. 6940 (including charging unit)

Inverter efficiency = 98%

Expected inverter life = 5 yrs

Interest rate = 9%

The results presented in Fig. 7 show that the cost of stored energy for lead acid batteries comes out to be BDT 38.63/kWh. It is interesting to note that the cost of stored energy for lead acid batteries is higher than that of Lithium-Ion battery. Although Lithium-Ion batteries are more expensive, they have a higher depth of discharge and a longer average life that compensates its higher capital cost.



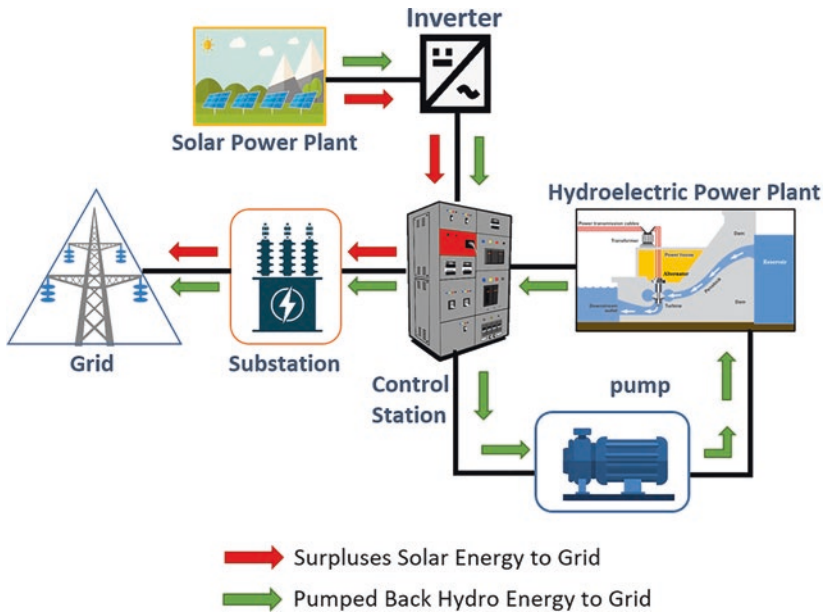
**Fig. 7** Cost per kWh and the percentage cost breakdown for Lead Acid battery-based energy storage. (Source: Own depiction)

These energy cost values indicate that battery-based storage is still very expensive and is not yet suitable for replacing the conventional peaking power plants, unless the price of the battery reduces by 50%.

## 4.2 Case 2: Solar PV with Hydro Reservoir

In this scheme, we consider the possibility of using Kaptai hydro plant as a pumped storage facility. The basic schematic diagram is shown in the Fig. 8. The Kaptai project has a vast area of land still not in use and installing a large-scale PV power generating plant is possible. Government has already installed a 7.4 MWp solar PV plant and there is ample space to install more. In this scheme, we propose to use solar PV energy to pump water from the downstream of Kaptai dam back to the reservoir to be used during the peak hours. As solar PV energy cost is lower than the average cost of grid energy, it is expected that the pump storage will be cost effective. Although there is no additional cost needed for the water storage (as it already exists), there are cost involvements in constructing a small water lock downstream to hold the discharged water from the dam during electricity production. The height of the lock should be such that it will only retain the required amount of water and the rest will spill over to the main river. As shown in Fig. 8, the PV is connected to the grid via grid tied inverter and the pump is run from the control station as per requirement decided by the BPDB. So, any surplus power is directed to the grid when the pump is not running.





**Fig. 8** Flow diagram of the proposed pumped hydro scheme. (Source: Own depiction)

The pump operation is controlled from the control station depending on the following factors.

- Existing water level of the reservoir
- Rainfall in the region and water level in the downstream Karnaphuli river
- Forecast of rainfall in the catchment area

It is expected that there will be times when pumping up of water will not be necessary and under such circumstances, the PV power is supplied to the grid. So, the scheme has the option to supply solar PV power partially or in total to the grid depending upon the reservoir water level and the load demand (Table 1).

In the following paragraphs, we present a study on the cost analysis of an 80 MWp solar PV plant for the pumped storage system. The basic assumptions are

**Table 1** Estimated pumping power requirements in different seasons. (Source: Own depiction)

Season	Month	% of pumped energy	Reasons behind variation in pumping scheme
Winter	Nov–Feb	10%	Less peak demand
Summer	Mar–May	80%	High peak demand Scarcity of water in upper reservoir
Monsoon	Jun–Oct	25%	Heavy rainfall Maximum volume of water in upper reservoir

Proposed size of solar PV plant = 80 MWp

Plant factor for the solar plant = 76%

Cost of PV energy (with grid tied inverter) = BDT 5.52 (LCOE)/kWh

Maximum pumping power = 50 MW

Efficiency of the pumping system = 76%.

Cost of the pumping system with accessories = BDT 283,081,150/MW

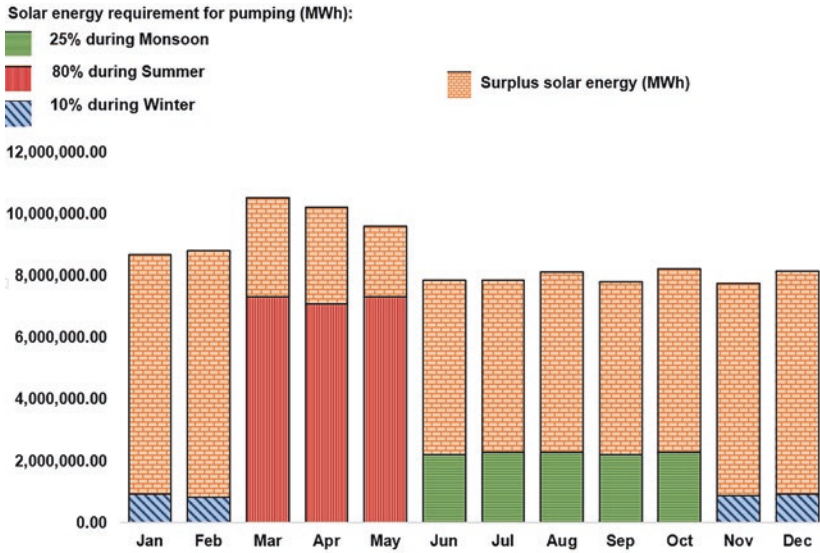
Civil engineering cost (downstream reservoir) = BDT 366,632,324

Interest rate = 9%.

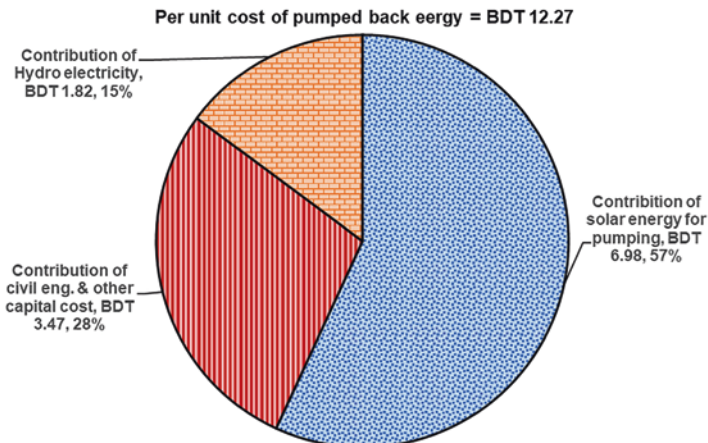
In calculating the pumped hydro energy cost, we considered the energy production from the solar PV under the prevailing sunshine condition (average of 4.5 kWh/m<sup>2</sup>) and estimated pumping power requirements as shown in Fig. 9.

We can see that the pumping power requirement is very low in the months from November to January due to low power demand in the winter season and low water supply from upstream. The pumping power is highest in the months from March to May as it is the peak summertime with low average rainfall when the power demand is high during the peak hours. The months from June to October, there is enough rainfall in the reservoir catchment area and scope of pumping water back to the reservoir is limited.

The calculated cost for the solar PV based pumped hydro, as presented in Fig. 10, comes out to be significantly lower (BDT 12.27) than the average peaking power plant energy cost. However, we need to keep it in mind that Bangladesh has only one hydro-electric plant and we do not have the option to extend it beyond Kaptai. It is possible to build small sized reservoirs on small brooks that run in the valleys in the Hill Tracts to store enough water corresponding to a single day requirement only, but in those cases cost of reservoir and dam will be added to the capital cost and the cost of energy may not be very low.



**Fig. 9** Seasonal pumping requirement and solar PV output. (Source: Own depiction)



**Fig. 10** Cost per kWh and the percentage cost breakdown for pumped back hydro system. (Source: Own depiction)

### 4.3 Case 3: Solar PV-HFO Hybrid Plant to Address the Peak Load

The option of pumped hydro is very limited in Bangladesh as we have only one hydro project. So, it cannot be a general solution for peaking power plants. In this section, we make a theoretical analysis on the option where solar PV is used for power generation during the daytime and a corresponding HFO plant is established to supply the power during the peak hours. The rationale behind such an idea may look unrealistic, as one can always argue that any HFO based plant established for peaking power can take share of the base load during the non-peaking hours as well and sharing base load will reduce the overall cost per kWh. But the proposal can be justified economically from a different perspective. As it is an established fact that solar PV based electricity has become cheaper than HFO based electricity, generating solar PV based electricity during the daytime will save the generation cost of the HFO plants. If the net cost of energy in a solar PV+HFO hybrid project is less than the cost of generating power using an HFO based plant alone, then we can always justify such a project. Additionally, it will improve the carbon footprint of the power system.

As a test case, we considered a 100 MWp solar PV based power plant and to share the corresponding peak load we consider a HFO based plant in the hybrid system having a power capacity of 80 MW. The cost of HFO in the international market varies and the average price can be assumed close BDT 25/L. However, we took a more conservative approach and assumed the cost of HFO to be BDT 22/L and cost of electricity in a HFO plant to be BDT 9.50/kWh. The annual cost figures for the project are presented below.

Expected energy production form the Solar PV plant = 131.5 GWh

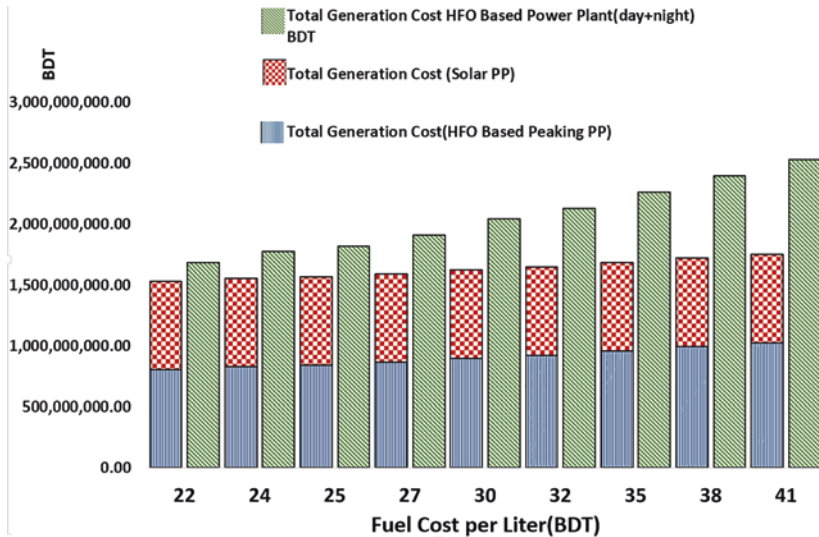
At Tk. 5.52/kWh, cost of solar energy = BDT 726 million

Estimated cost in a HFO plant to generate 131.5 GWh = BDT 1249 million

So, cost saving by using solar PV is = BDT 523 million.

This cost saving would increase to Tk. 622 million if the HFO price is BDT 25/L (see Fig. 11).

Now let us estimate the cost of running the HFO generators to generate peak power only. The running time of the peaking plants vary from 2–6 h depending on the load demand that varies with season and weather condition and the average is close to 3.5 h per day. Based on the BPDB data with seasonal variation of the peaking load, the yearly energy cost of an 80 MW peaking power plant comes



**Fig. 11** Generation costs for solar PV-HFO hybrid plant vs. a HFO based plant. (Source: Own depiction)

out to be BDT 809.48 million at a peaking power rate of BDT 17.50/kWh (estimated from BPDB peaking power plant data). So, the total annual cost, including the peaking load, is BDT 1535.48 million. On the other hand, an 80 MW plant generating the same amount of energy will cost BDT 1688.4 (including the peaking hours) at a rate of BDT 9.5/kWh. So, we can see that there is a cost saving of BDT 152.92 when a solar PV-HFO hybrid plant is considered. A comparative energy cost data for solar PV-HFO hybrid plant and a solely HFO based plant is given in Fig. 11 for different HFO prices. It may be mentioned here that we considered an 80 MW HFO plant as an equivalent of the solar PV of 100 MWp. If we look at the sunshine in Bangladesh, which varies from 4.5 to 4.7 kWh/m<sup>2</sup> with a plant factor of 76%, a 50 MW HFO plant should suffice. In that case the cost saving will be even higher (BDT 290 million).

The above analysis gives a very interesting economic option to use solar PV-HFO hybrid power plants to cater for both the daytime load and the peak hour load at a lower cost compared to a solely HFO driven plant. Additionally, the cost of carbon saving in such a scheme is around BDT 70.3 million (at a carbon price of USD 30/ton) per year.

## 5 Policy Options for Bangladesh and Conclusions

Bangladesh has been slow to adopt renewable energy sources for its power generation needs as it treads its way through the financial challenges the nation faces. It is important to realize that implementation of any renewable energy project needs to be financially feasible with minimum or no subsidy so that it does not put undue pressure on the economy of the country. In some situations, a limited level of subsidy or incentive may be needed to initiate or promote new technologies, but large-scale subsidy is not realistic. The subsidy could be in the form of tax break, reduced import duty or soft term loans with low interest rate. Some of these are already in force, but more may be needed. Any such step can be interpreted as an effort to mitigate climate change and can be used to attract foreign investments and funding from international development cooperation agencies.

Solar PV appears to be the key focus area in Bangladesh's renewable energy sector, while other resources do not appear to be particularly promising. In the absence of solar PV production, an increased percentage of PV energy will necessitate a storage system for power system stability, as well as extra generating or storage capacity to meet peak demand (as peak demand occurs during the evening hours). The results presented here show that we can very effectively use the Kaptai hydro-electric project by using a solar PV based pumped hydro system, as such a peaking power scheme can provide power during peak hours at a cost at least 30% lower than the average existing peaking energy cost. However, such a project is not scalable as we do not have any other hydro power plant. If additional reservoirs were naturally found within the national border, Kaptai experience could be replicated. Joint venture hydropower plant projects in the region (e.g., Indian north-east, Bhutan, Nepal) are an additional avenue that could be pursued to create solar PV power stations plus hydro storage combination.

Solar PV—HFO hybrid plants also offer financial feasibility. This appears to be a promising way to go since, unlike solar PV-hydro storage hybrid plants, it is not constrained by the natural environment. In our analysis, we considered the possibility of using solar PV for power generation during the day hours and set up additional HFO plants to cater to the additional peak load resulting from the unavailability of solar PV power in the evening. It has been shown that the fuel cost saving during the daytime is enough to economically run solar PV-HFO hybrid plants with a generation cost lower than a purely HFO based power plant. This ensures increased renewable energy share without increasing the cost of energy production. This is an important result in the sense that Bangladesh is running out of its own gas reserve and importing natural gas will increase the gas price by a

significant margin. Once imported gas is injected in the grid, the price of the natural gas-based electricity will no more be as attractive as it is today. If we consider this scenario, solar PV-HFO hybrid plants seem to be the best possible economic solution.

Using the large-scale battery storage systems as a peak load shaving technique does not look economically viable, as the battery cost is too high. The interest rate in Bangladesh is quite high (~9% has been assumed in the analysis) and it keeps on changing over the years. In most of the developed countries, the interest rate is lower than 5% and the corresponding cost of energy is usually much lower when compared to its cost in Bangladesh. Moreover, the developed countries have the economic resilience to subsidize many of such projects to curb Greenhouse Gas (GHG) emission as a part of their commitment to the reduction of global warming. That level of subsidy will not be possible for a developing country like Bangladesh, but policy makers should encourage small scale grid connected solar PV projects with battery back up to enhance the stability of the power system. In such projects, the size of the battery will not be large enough to reduce the peak load but would be sufficient from a stability point of view.

Financial figures do not point to immediate feasibility for Solar PV—battery storage hybrid power stations. Despite this, Bangladesh's recent transition to middle income country may justify supporting one or more such power stations initially supported by subsidy, research fund or grants as a multitude of change is coming from the technology front (battery technology), financial front (interest rates), knowledge front (learning by doing), global climate change mitigation front (grant) and national energy security front (budgetary support). This could make this battery-based energy storage plant financially feasible as a stand-alone system or in combination with a solar PV power system.

Additional factors are also in play to change the inertia in policy circles that usually favors the use of traditional hydrocarbon sources for electrical power. One of the most important factors in this regard is the increasing concern of sustainability in using hydrocarbon-based energy sources as their price stability cannot be ascertained for the duration of the plant life, particularly for those plants that are on the design table now. Adding to that uncertainty, Bangladesh also faces pressures from different stakeholders to get its green credential in the right place while it pursues funds for climate change mitigation and adaptation purposes. An added incentive to pursue solar as well as other renewable sources for power generation is that it offers the possibility to gain financially from carbon credit and to avoid financial loss that may evolve from direct or indirect carbon tax.



## References

- Barapukuria Coal Mining Company Limited. (2021). *Coal Mining Development*. Bcml. Org.Bd. April 15. <https://bcmcl.org.bd/coal-mining-development/>. Accessed: 16 Apr 2021.
- BPDB, Bangladesh Power Development. (2021). *BPDB*. April 8. [http://www.bpdb.gov.bd/bpdb\\_new/index.php/site/page/13e9-2cc0-ce41-9c09-088d-94d5-f546-04a6-b4fa-1d18](http://www.bpdb.gov.bd/bpdb_new/index.php/site/page/13e9-2cc0-ce41-9c09-088d-94d5-f546-04a6-b4fa-1d18).
- Chua, K. H., Lim, Y. S., & Morris, S. (2013). Battery energy storage system for peak shaving and voltage unbalance mitigation. *International Journal of Smart Grid and Clean Energy* 2(3): 357–363.
- Department for Business, Energy & Industrial Strategy. (2020). Domestic Battery Energy Storage Systems. *GOV.UK*. GOV.UK. October 2. <https://www.gov.uk/government/publications/domestic-battery-energy-storage-systems>. Accessed: 17 Apr 2021.
- Energy Information Administration – EIA. (2021). Electric Power Monthly – U.S. *Eia.Gov*. [https://www.eia.gov/electricity/monthly/epm\\_table\\_grapher.php?t=table\\_5\\_03](https://www.eia.gov/electricity/monthly/epm_table_grapher.php?t=table_5_03).
- Faijer, M. J., & Arends, E. (2017). Wind energy potential Bangladesh. *Netherlands Enterprise Agency*. Hans Rijntalder, April 2017. <https://www.rvo.nl/sites/default/files/2017/05/baseline-study-wind-energy-bangladesh.pdf>. Accessed: 18 Apr 2021.
- Gellings, C., Barron, W., Betley, F. M., England, W. A., Preiss, L. L., & Jones, D. E. (1986). Integrating demand-side management into utility planning. *IEEE Transactions on Power Systems*, 1, 81–87. <https://doi.org/10.1109/TPWRS.1986.4334958>. Accessed: 17 Apr 2021.
- IEA. (2020a). Energy Technology Perspectives 2020a. *iea.org*. IEA. <https://www.iea.org/reports/energy-technology-perspectives-2020>. Accessed: 25 Apr 2021.
- IEA. (2020b). *Evolution of solar PV module cost by data source, 1970–2020b*. June 30. <https://www.iea.org/data-and-statistics/charts/evolution-of-solar-pv-module-cost-by-data-source-1970-2020>. Accessed: 9 Apr 2021.
- IEA. (2015). *Medium-term renewable energy market report 2015*. IEA.
- IRENA. (2021). Renewable energy capacity statistics 2021. (International Renewable Energy Agency) 2-38. [https://www.irena.org/-/media/Files/IRENA/Agency/Publication/2021/Apr/IRENA\\_RE\\_Capacity\\_Statistics\\_2021.pdf](https://www.irena.org/-/media/Files/IRENA/Agency/Publication/2021/Apr/IRENA_RE_Capacity_Statistics_2021.pdf). Accessed: 9 Apr 2021.
- Karim, Md E., Munir, A. B., Karim, M. A., Muhammad-Sukki, F., Abu-Bakar, S. H., Sellami, N., Bani, N. A., & Hassan, M. Z. (2018). Energy revolution for our common future: An evaluation of the emerging international renewable energy law. *Energies*, 11(7), 1769. <https://doi.org/10.3390/en11071769>. Accessed: 19 Apr 2021.
- Lu, R., Hong, S. H., & Zhang, X. (2018). A Dynamic pricing demand response algorithm for smart grid: Reinforcement learning approach. *Applied Energy*, 220, 220–230. <https://doi.org/10.1016/j.apenergy.2018.03.072>. Accessed: 17 Mar 2021.
- Nourai, A., Kogan, V. I., & Schafer, C. M. (2008). Load leveling reduces T&D line losses. *IEEE Transactions on Power Delivery*, 23, 2168–2173. <https://doi.org/10.1109/TPWRD.2008.921128>. Accessed: 2021.
- Popp, M. (2010). Storage for secure power supply from wind and sun. *Springer* (Springer-Verlag Berlin Heidelberg). <https://doi.org/10.1007/978-3-642-01927-2>.



- Power Grid Company of Bangladesh Limited. (2021). *Report on forecasted generation & demand of national grid on 29-April-2021*. Daily Report, Dhaka: Bangladesh Power Development Board. <https://web.pgcb.gov.bd/report/2901/download>. Accessed: 30 Nov 2021.
- Preuster, P., Alekseev, A., & Wasserscheid, P. (2017). Hydrogen storage technologies for future energy systems. *Annual Review of Chemical and Biomolecular Engineering*, 8, 445–471. <https://doi.org/10.1146/annurev-chembioeng-060816-101334>
- Rehman, S., Al-Hadhrani, L. M., & Alam, M. (2015). Pumped hydro energy storage system: A technological review. *Renewable and Sustainable Energy Reviews*, (44), 586–598. <https://doi.org/10.1016/j.rser.2014.12.040>. Accessed: 9 Apr 2021.
- Ritchie, H. (2021). Electricity mix. *OurWorldInData.org*. Our World in Data. <https://ourworldindata.org/grapher/nuclear-renewables-electricity>. Accessed: 25 Apr 2021.
- Ritchie, H., & Roser, M. (2020). Renewable energy. *Our World in Data* (OurWorldInData.org). <https://ourworldindata.org/renewable-energy>. Accessed: 10 Apr 2021.
- SREDA. (2020). *National Solar Energy Roadmap 2021–2041(DRAFT)*. Government Roadmap, Dhaka: SREDA, 82–109. <http://www.sreda.gov.bd/site/notices/2ee87680-e210-481e-bf40-126ac67949a2/DRAFT---National-Solar-Energy-Roadmap-2021---2041>. Accessed: 8 Apr 2021.
- SREDA. (2021). *Renewable energy statistics*. renewableenergy.gov.bd. April 20. <http://www.renewableenergy.gov.bd/index.php?id=8>. Accessed: 21 Apr 2021.
- Uddin, M., Romlie, M. F., Abdullah, M. F., Halim, S. A., Abu Bakar, A. H., & Kwang, T. C. (2018). A review on peak load shaving strategies. *Renewable and Sustainable Energy Reviews*, 82(Part 3), 3323–3332. <https://doi.org/10.1016/j.rser.2017.10.056>. Accessed: 17 Apr 2021.
- Wikipedia Contributors. (2021a). *Battery storage power station*. Vers. 1016133409. Wikipedia, The Free Encyclopedia. April 5. [https://en.wikipedia.org/w/index.php?title=Battery\\_storage\\_power\\_station&oldid=1016133409](https://en.wikipedia.org/w/index.php?title=Battery_storage_power_station&oldid=1016133409). Accessed: 7 Apr 2021a.
- Wikipedia Contributors. (2021b). *Tesla Powerwall*. Vers. 1017766071. Wikipedia, The Free Encyclopedia. April 14. [https://en.wikipedia.org/w/index.php?title=Tesla\\_Powerwall&oldid=1017766071](https://en.wikipedia.org/w/index.php?title=Tesla_Powerwall&oldid=1017766071). Accessed: 17 Apr 2021b.

**Open Access** This chapter is licensed under the terms of the Creative Commons Attribution 4.0 International License (<http://creativecommons.org/licenses/by/4.0/>), which permits use, sharing, adaptation, distribution and reproduction in any medium or format, as long as you give appropriate credit to the original author(s) and the source, provide a link to the Creative Commons license and indicate if changes were made.

The images or other third party material in this chapter are included in the chapter's Creative Commons license, unless indicated otherwise in a credit line to the material. If material is not included in the chapter's Creative Commons license and your intended use is not permitted by statutory regulation or exceeds the permitted use, you will need to obtain permission directly from the copyright holder.





# Low-Carbon Energy Transformation in China, India, Pakistan, and Afghanistan: An Overview

Abdullah Fahimi and Kai Stepputat

## Abstract

Approximately 40% of the world's population lived in China, India, Pakistan, and Afghanistan in 2021. These countries were responsible for about 36% of the world's CO<sub>2</sub> emissions in 2018. Economically, in the same year they represented 20% of the global Gross Domestic Product (GDP). Considering the population, the CO<sub>2</sub> emissions, and the share of their GDP in world economy, actions in these countries regarding fighting climate change and promoting low-carbon energy transformations have global consequences and are key to realization of 2015 Paris Agreement and Sustainable Development Goals (SDGs) (e.g., SDG7 and SDG13). In this article, we review the current energy situation, low-carbon energy targets and challenges to low-carbon energy transformation in each country and provide an overview of general trends and key factors in this transformation. The assessment shows that the above countries are not on the path to achieve the Paris Agreement target. CO<sub>2</sub> emissions and the use of fossil fuels are still high in these countries. However, general trends such as decreasing costs of renewables, a decreasing dependency on

---

A. Fahimi (✉)

Institute of Sustainability Governance (INSUGO), Leuphana University,  
Lüneburg, Germany

e-mail: [abdullah.fahimi@stud.leuphana.de](mailto:abdullah.fahimi@stud.leuphana.de)

K. Stepputat

Technical University of Berlin, Berlin, Germany

e-mail: [stepputat@campus.tu-berlin.de](mailto:stepputat@campus.tu-berlin.de)

© The Author(s) 2023

S. Groh et al. (eds.), *Electricity Access, Decarbonization, and Integration of Renewables*, Energiepolitik und Klimaschutz. Energy Policy and Climate Protection, [https://doi.org/10.1007/978-3-658-38215-5\\_5](https://doi.org/10.1007/978-3-658-38215-5_5)

fossil fuels imports, additional liquidity for energy infrastructure due to fuel costs savings, and remuneration schemes for renewables are all promising for decarbonisation efforts and low-carbon energy transformation.

---

**Keywords**

Low-carbon energy transformation · Global South · China · India · Pakistan · Afghanistan

---

## 1 Introduction

The four countries China, India, Pakistan, and Afghanistan play a crucial role regarding climate change. Representing approximately 40% of the world's population in 2021, around 20% of the world's GDP in 2019 and around 36%<sup>1</sup> of the world's CO<sub>2</sub> emissions in 2018 (World Bank, 2016b, 2020, 2021c; IEA, 2018d, 2020a, d, e), their energy development pathways have significant impacts on the world's climate.

On the one hand, due to their economic and social characteristics, including economic catch-up processes and ongoing inner demographic processes and trends such as urbanization, a growing middle class and changing consumer patterns, they contribute significantly to the rise of CO<sub>2</sub> emissions. Efforts to increase access to energy, especially in the latter three countries, could further contribute to emissions rise if relied on fossil fuels instead of low-carbon energy sources.

On the other hand, these countries, in particular China and India, are strongly promoting the development of renewable energies, for example through the expansion of wind and solar capacities. Between 2015–2017, additions of coal capacity in developing countries have decreased significantly, most of it due to reductions in China and India, which have simultaneously promoted the development of renewable energies (Nicholas & Buckley, 2018). Total installed renewable capacities in 2020 were 2,799 GW, of which China had a percentage of 31.97%, India 4.79%, Pakistan 0.44% and Afghanistan around 0.013%, so in total the installed renewable capacities of these countries combined was more than 37.2% of the world's share (IRENA, 2021a).

---

<sup>1</sup>This is an estimated number as the latest available CO<sub>2</sub> emission figures from Afghanistan are from 2016.

In the following, an overview of the current energy situation will be given for the countries People's Republic of China (hereafter China), Republic of India (hereafter India), Islamic Republic of Pakistan (hereafter Pakistan), and Islamic Republic of Afghanistan (hereafter Afghanistan). For each country, a brief context will be followed by a short overview of energy production, consumption, and renewable energy potential. As electricity is becoming increasingly important as an energy carrier to meet increasing energy demands and to decarbonise sectors such as transport and heating, the focus in these sections is on electricity. Data from the International Energy Agency (IEA) and World Bank, our two main data sources, is complemented by information from national authorities. Each country section will conclude by identifying challenges to the low-carbon energy transformation. The country sections will be followed by a section on general trends and key factors. The paper concludes with discussing the developments in the four countries regarding the low-carbon energy transformation.

---

## 2 China

### 2.1 Introduction

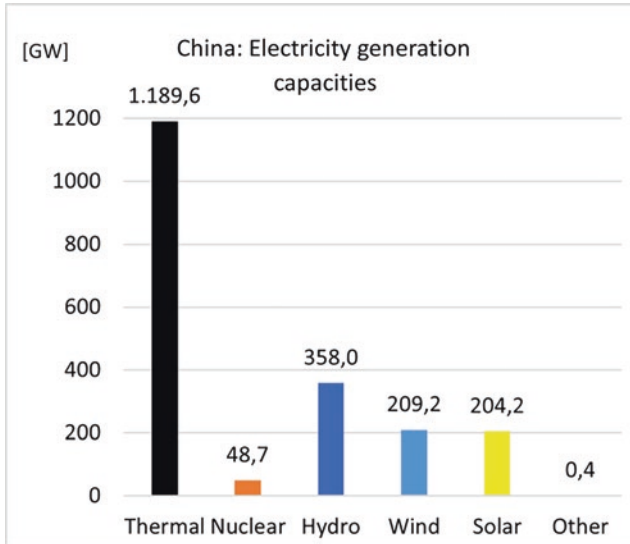
With a total CO<sub>2</sub> emission of 9.528 Gt in 2018, China is by far the largest emitter of CO<sub>2</sub> (IEA, 2020a). With a population of 1.412 billion in 2021, China is also the world's most populous country (World Bank, 2021c). Despite the enormous economic growth of the country in recent decades, both total CO<sub>2</sub> emissions and CO<sub>2</sub> emission per capita remained relatively constant in the period from 2013 to 2018 (IEA, 2020a, c).

### 2.2 Production and Supply

Total primary production of energy in China was 3,970,000,000 tce (i.e., equivalent to around 2,779,037 ktoe) in 2019. Raw coal had a percentage of 68.6% of the total energy production, crude oil 6.9% and natural gas 5.7%. Primary electricity and other energy accounted for 18.8% of the total energy production (National Bureau of Statistics of China, 2021a).

According to the IEA, total energy supply to China was 3,197,631 ktoe in 2018, of which coal had a share of 61.9%, oil 19.1% and natural gas 7.2% (IEA, 2020a).

As depicted in Fig. 1, total generation capacity for electricity in China was around 2,010 GW, of which thermal had a share of around 59%. Renewables



**Fig. 1** Electricity generation capacities in China in 2020. (Source: National Bureau of Statistics of China, 2021c)

(including hydro) accounted for around 38.4% (National Bureau of Statistics of China, 2021c).

According to the International Renewable Energy Agency (IRENA), with a total capacity of renewables of about 894.9 GW in 2020, China owns the largest installed renewable capacity in the world with a world's share of 31.97%. This proportion increased from 20.14% in 2011. While hydro has the highest percentage of installed renewable capacity, wind and solar energy show the highest growth rates. The increase in solar capacity from 2019 to 2020 in China was around 49.4 GW, almost five times as high as the total installed solar capacity in whole of Africa in 2020 (10.6 GW) (IRENA, 2021a).

### 2.3 Consumption and Demand

Currently, China is the world's biggest energy consumer. The country's total primary energy demand was about 3,314 Mtoe in 2019, which is about 23.0% of the world's share (IEA, 2020g). China's total energy consumption in 2019 was

around 4,870,000,000 tSCE (i.e., equivalent to around 3,409 Mtoe), of which coal had a percentage of 57.7%, petroleum 18.9%, natural gas 8.1%, primary electricity and other sources accounted for 15.3% (National Bureau of Statistics of China, 2021b).

According to the World Energy Outlook 2020, China's coal demand was 2,864 Mtce in 2019, oil demand 13.2 mb/d and natural gas demand 307 bcm. According to the *Stated Policies Scenario* for 2040, coal demand is estimated to be 2,524 Mtce, oil demand 14.1 mb/d and natural gas demand 637 bcm. For the *Sustainable Development Scenario*, coal demand is estimated to be 1,045 Mtce, oil demand 8.9 mb/d and natural gas demand 511 bcm in 2040 (IEA, 2020g).

## 2.4 Renewable Energy Potential

According to the IEA, additional 489 GW of installed renewable capacity is expected to become operational between 2019–2024 in China, which is the largest increase in renewable capacity of a single country in this period in the world. 84% of this capacity increase is expected to come from wind and solar PV (IEA, 2019b).

China's photovoltaic power potential varies greatly from around 1,000–1,300 kWh/kWp yearly along the populous East Coast to around 1,650 kWh/kWp in the Inner Mongolia and around 1,850 kWh/kWp in Tibet Autonomous Region. For comparison: the specific photovoltaic power output in Berlin is around 1,059 kWh/kWp per year (Global Solar Atlas 2.0 2019a, 2021).

China's wind energy potential is very diverse, the highest mean wind speeds can be measured in the Inner Mongolia and Tibet Autonomous Region. The 10% windiest areas of China have an average wind speed of 8.93 m/s (Global Wind Atlas 3.0, 2021a).

## 2.5 Low-Carbon Energy Targets

Five-years plans, published by the Communist Party, play a significant role in the economic development of China. In the 14th five-year plan for the period from 2021 to 2025, China states to “formulate an action plan to reach peak carbon emissions by 2030”. Moreover, “carbon neutrality by 2060” and “more forceful policies and measures” are planned (Xinhua News Agency, translated on behalf of Center for Security and Emerging Technology (CESET), 2021, 94).

The World Energy Outlook 2020, published by the International Energy Agency (IEA), describes several energy consumption scenarios for the world and various large economies, such as China and India. In the *Stated Policies Scenario*, defined by the IEA as “based on today’s policy settings and an assumption that the pandemic is brought under control in 2021”, total CO<sub>2</sub> emissions of 9.111 Gt are forecasted by 2040 for China (IEA, 2020g, 27, 396). This is almost three times as much as forecasted for China in the *Sustainable Development Scenario*, defined as a scenario with “a near-term surge of investment in clean energy technologies in the next ten years”. In this scenario, CO<sub>2</sub> emissions of 3.078 Gt for China in 2040 are projected (IEA, 2020g, 28, 397).

## 2.6 Challenges to Low-Carbon Energy Transformation

The potential increase in China’s renewable energy capacity between 2019–2024, according to the IEA’s calculations, will be a significant 489 GW mainly due to enhanced cost competitiveness of solar and wind and more onshore wind because of a reduced curtailment in northern China. However, the ongoing policy transition from feed-in tariffs (FITs) to competitive auctions remains a key uncertainty factor (IEA, 2019b).

Despite the enormous economic development China has undergone in the last decades, there are millions still living in poverty in several regions, especially in the less-developed western and rural areas of the country showing a contrast to the coastal metropolises in the east and industrialized centres. Social inequality is also a major problem. Moreover, the current dominant social imaginary in the country is assessed to be against the reduction of emissions and compliance with climate change agreements and environmental limits as they are often interpreted as abstention of consumption and restriction of development. A public information campaign emphasizing the importance of a combination of sustainable growth with the required reduction of emissions might be a possible solution (Burandt et al., 2019).

---

## 3 India

### 3.1 Introduction

With a population of 1.393 billion in 2021, India is the second most populated country in the world (World Bank, 2021c). Total CO<sub>2</sub> emission from India accounted for

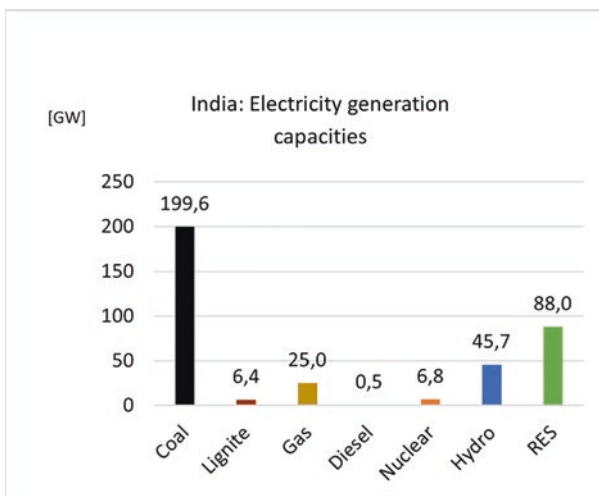
about 2.308 Gt in 2018 (IEA, 2020d). From 2000 to 2018, CO<sub>2</sub> emissions per capita more than doubled from 0.8 tonnes per capita in 2000 to 1.7 tonnes per capita in 2018 (IEA, 2018a).

From 2000–2019, about 750 million people in India obtained access to electricity (i.e., SDG 7) (IEA, 2020f; United Nations, 2020). With a growing middle-class, increased urbanization and social mobility, one of the biggest consumer markets could emerge in India (Ramakrishnan et al., 2020). According to the current policies, energy demand in India could double by 2040. Electricity demand could, according to the IEA, potentially triple by 2040 due to increased ownership of appliances and cooling devices (IEA, 2020f).

### 3.2 Production and Supply

Total energy supply in India was 919,771 ktoe in 2018, dominated by coal with a share of 45.0%. Oil had a share of around 25.6% and biofuels and waste made up about 20.1% of the total energy supplied to the population (IEA, 2020d).

As depicted in Fig. 2, total electricity generation capacity in India on 31.08.2020 was around 373 GW, dominated by thermal with a share of 62.1%, followed by



**Fig. 2** Electricity generation capacities in India in 2020. (Source: Central Electricity Authority, Ministry of Power, 2020)



solar and wind, with a combined share of 23.8%. Hydro had a share of 12.3% in the electricity mix (Central Electricity Authority, Ministry of Power 2020).

Total installed renewable capacity was about 134.2 GW in 2020. Especially solar capacity strongly increased in the last years, with growth rates of 50.7% in 2018, 28.3% in 2019 and 11.7% in 2020. India's global share of renewable capacity is about 4.79% (IRENA, 2021a).

### 3.3 Consumption and Demand

India's total primary energy demand in 2019 was around 929 Mtoe. Coal demand was 590 Mtoe, oil demand 5.0 mb/d and natural gas demand 63 bcm. According to the IEA's *Stated Policies Scenario*, for 2040, coal demand is estimated to be 772 Mtoe, oil demand 8.7 mb/d and natural gas demand 201 bcm. For the *Sustainable Development Scenario*, coal demand is estimated to be 298 Mtoe, oil demand 5.8 mb/d and natural gas demand 210 bcm in 2040 (IEA, 2020g).

### 3.4 Renewable Energy Potential

India's photovoltaic power potential is relatively evenly distributed ranging from around 1,400 kWh/kWp in the Gangetic Plains to around 1,700 kWh/kWp in the westernmost parts of the country (Global Solar Atlas 2.0, 2019b).

Compared to China, India's wind energy potential is smaller, with a relatively low mean wind speed especially in the northern and eastern areas of the country. The 10% windiest areas have an average wind speed of 6.58 m/s (Global Wind Atlas 3.0, 2021b).

According to the IEA, renewable installed capacity in the country is expected to almost double in the period from 2019–2024 due to competitive auctions for PV and wind to 235 GW in 2024—an increase of 112 GW compared to 123 GW installed capacity in 2018 (IEA, 2019b).

### 3.5 Low-Carbon Energy Targets

The total CO<sub>2</sub> emission of India in 2018 was 2.31 Gt (IEA, 2019a). According to the World Energy Outlook 2020, CO<sub>2</sub> emissions of India in 2040 are projected to be 3.359 Gt in the *Stated Policies Scenario* and 1.46 Gt in the *Sustainable Development Scenario* (IEA, 2020g, 400, 401).

In its Nationally Determined Contributions (NDC), India declared to decrease its emissions level by 20–25% in 2020 compared to 2005, and stated concrete programmes for renewable capacity expansion by 2022 (Government of India, 2016).

### 3.6 Challenges to Low-Carbon Energy Transformation

According to the IEA, the future growth of renewables in India depends on the financial and operational capability of its distribution companies (DISCOMs), the development of Green Energy Corridors, a project aiming to synchronize renewable electricity with conventionally generated electricity by implementing transmission lines (Ministry of New and Renewable Energy, Government of India, 2020), and programmes to enhance access to affordable funding. A further challenge is the acquisition of required land (IEA, 2019b).

---

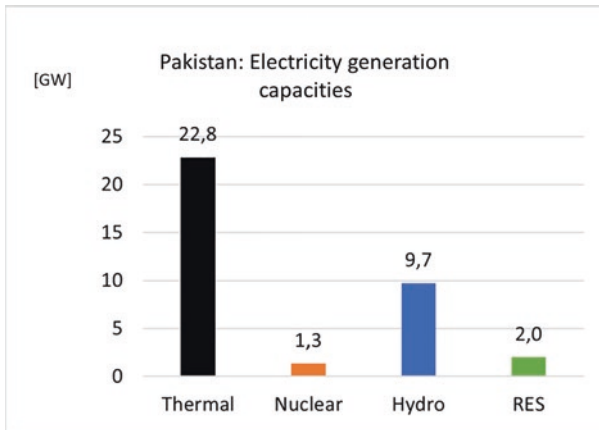
## 4 Pakistan

### 4.1 Introduction

While a total CO<sub>2</sub> emissions of 183 Mt and per capita CO<sub>2</sub> emissions of about 0.9 tonnes in 2017, Pakistan was still considered a relatively small emitter compared to other countries globally or in the region. These figures are rising with the country having a lot to develop, currently ranking 152nd in the Human Development Index (HDI) with a score of 0.560 in 2019 (IEA, 2018b, 2018c; United Nations Development Programme, 2019). In the electricity sector, there are many reports of frequent and substantial blackouts; however, up-to-date empirical data is rare. A power deficit (difference between generation capacity and demand) of 22.11 GW in 2016 and 17.67 GW in 2015 has been calculated and estimated to increase to 45.5 GW in 2025 due to an increase in population and therefore demand (Baloch et al., 2019).

### 4.2 Production and Supply

Total primary energy supply for Pakistan was around 111,232 ktoe in 2018. Bio-fuels and waste accounted for the largest share (32.7%), oil 26%, natural gas 25.4% and coal 10.2% (IEA, 2020e).



**Fig. 3** Electricity generation capacities in Pakistan in 2019. (Source: National Electric Power Regulatory Authority, 2019)

As depicted in Fig. 3, total generation capacity for electricity in Pakistan was around 36 GW in 2019. Thermal capacities had a share of around 63.6%, followed by hydro with a share of 27.1% and other renewables with a share of 5.6% (National Electric Power Regulatory Authority, 2019).

Renewable capacities are historically dominated by hydro in Pakistan. In the recent years, also wind and solar capacities grew, but from a very low initial level, reaching around 1.2 GW wind capacity and around 0.7 GW solar capacity in 2020 (IRENA, 2021a).

### 4.3 Consumption and Demand

Pakistan's total final consumption of energy was 95,594 ktoe in 2018. Total final consumption of coal was 7,933 ktoe in 2018, and a further 21,937 ktoe of oil products and 20,071 ktoe of natural gas was consumed in this year (IEA, 2020b).

### 4.4 Renewable Energy Potential

According to the IEA, renewable electricity capacity in Pakistan is expected to increase from 13 GW in 2018 to 22 GW in 2024 (IEA, 2019b). Pakistan's

photovoltaic power potential ranges from around 1,200 kWh/kWp in the mountainous north, about 1,600 kWh/kWp in the densely populated eastern lowlands to up to 2,000 kWh/kWp in the mountainous Balochistan province in south-western of Pakistan (Global Solar Atlas 2.0, 2019c). The country's wind energy potential varies widely, with the south-western and southern parts of the country being the most promising. The 10% windiest areas have an average wind speed of 7.87 m/s (Global Wind Atlas 3.0, 2021c).

#### 4.5 Low-Carbon Energy Targets

Pakistan highlights its potential emission reduction regarding projected (future) emissions in its Intended Nationally Determined Contribution, submitted in November 2016. According to the document, 20% of the projected emissions in 2030 could be reduced with an investment of around \$ 40 billion. A diminishing marginal utility is stated: A 10% reduction could be achieved with an investment of around \$ 5.5 billion, and a 15% reduction with an investment of \$ 15.6 billion. However, to realize those emission reductions, Pakistan's NDC is requesting international financial and technical support (Government of Pakistan, 2016).

Presumably since Pakistan is neither a member country nor an associated country of the International Energy Agency, the World Energy Report does not provide dedicated data for Pakistan. Instead, Pakistan is included in the Asia Pacific Region (IEA, 2020g).

Pakistan's energy structure is also highly impacted by the China Pakistan Economic Corridor (CPEC), which is part of the Belt and Road Initiative. The CPEC, a \$ 60 billion project according to reports in July 2018, provides more than \$ 35 billion of Chinese loans for new power stations in Pakistan, most of them coal-fired (Stacey, 2018). These developments are not in line with climate change agreements.

#### 4.6 Challenges to Low-Carbon Energy Transformation

Barriers to achieve 100% renewables in Pakistan are manifold. These include a lacking political will in the country for a sustainable energy transition (shown by examples such as subsidies for fuel-based electricity or plans to integrate only 5% renewables in 2030) and a limited public awareness regarding renewable energy which has led to the general perception that renewables are expensive and unreliable. Moreover, a weak infrastructure undermines developments in the sector.

Collapses of the electricity system are common, especially during peak-demand hours. The current electricity transmission and distribution systems can only just transport half of the total demand for electricity. Large investments in the national grid are therefore urgently needed, but a large proportion of them are going into fossil-based solutions (Shah & Solangi, 2019).

---

## 5 Afghanistan

### 5.1 Introduction

One of the least developed countries, Afghanistan is a mountainous landlocked country located at the crossroads of Central Asia and South Asia. Since no official census has been conducted for decades, figures on the population of the country are conflicting. The World Bank estimates the country's population to be 39.835 million in 2021 (World Bank, 2021c). Afghanistan shares borders with Pakistan in the south and east, Iran in the west, China in the northeast, and Turkmenistan, Uzbekistan, and Tajikistan in the north.

The country has one of the lowest rates of access to and usage of electricity in the world with an annual per capita consumption of 186 kWh (World Bank, 2016a; Korkovelos et al., 2017a). Since 2001, when the Taliban regime was ousted, the country has made progress in terms of access to electricity. This has risen fivefold from 6% to around 30% in 2015. However, there are substantial disparities between rural and urban population in terms of access to and usage of electricity. In rural areas, where around 67% of the country's GDP comes from and more than 77% of the population lives, less than 11% of them have access to grid power, while in large urban areas up to 90% have access to grid power (World Bank, 2016a).

Since 2001, billions of US dollars and dozens of development aid organizations have been supporting the development of the energy sector in Afghanistan. The major aid agencies in the sector are Gesellschaft für Internationale Zusammenarbeit (GIZ), the United States Agency for International Development (USAID), the Asian Development Bank (ADB), the World Bank, and the United Nations Development Programme (UNDP) (Fahimi & Upham, 2018). These and several other aid agencies have also supported the national power utility, Da Afghanistan Breshna Sherkat (DABS), and the energy sector in general in areas such as system loss minimization, revenue collection, distribution, capacity building, and policy design. With the financial and technical support of these aid organizations, most of the necessary institutions, laws, and policies in the sector's regulatory landscape have been developed or are being developed.

## 5.2 Production and Supply

The total installed power generation capacity in Afghanistan is roughly around 500 MW which comes mainly from large hydropower plants, thermal sources, and distributed diesel generators and renewables (Fahimi & Upham, 2018). Because it does not produce enough electricity to meet the growing demand, the country imports around 80% of its electricity needs from neighbouring Central Asian countries including Uzbekistan (37% of total imports), Tajikistan (29% of total imports), and Turkmenistan (10% of total imports) and its western neighbour Iran (23% of total imports) (Gencer et al., 2018).

A unified national electricity grid is lacking in the country. There are several regional supply systems, such as the North East Power System (NEPS) and the South East Power System (SEPS) which feed customers in the north, south, east, west and capital Kabul. These systems rely mostly on imported power from neighbouring countries. These regional supply systems and islands are not interconnected or synchronized. This problem stems from the fact that power systems of the neighbouring exporting countries are asynchronous (except for Turkmenistan and Iran which are synchronized). This makes it difficult for Afghanistan to synchronize them which then in turn negatively impacts trading and energy transfer (Gencer et al., 2018). Over the past two decades several development aid agencies including the USAID and the ADB have worked on transmission lines from neighbouring countries and within Afghanistan. The national power utility, DABS, which is also responsible for operation and management of electric power generation and imports is also in charge of transmission and distribution activities in the country.

## 5.3 Consumption and Demand

Peak demand in 2015, the latest reliable data available, was 1,500 MW and the total consumption was roughly 5,000 GWh (World Bank, 2016a). Demand in Afghanistan peaks in the winter while energy supply is at its lowest in this season due to the exporting countries' reduction of export to meet their own domestic needs. As we alluded to the low access rate and the disparity in access to electricity between rural areas and urban centres earlier, the unmet needs of most of the population, especially those in rural remote areas, are met by solid fuels such as fuelwood, charcoal, agricultural waste, and animal dung, particularly for heating and cooking purposes. In terms of urban and rural gap, 90.7% of the rural population use the mentioned fuels for cooking and 97.7% for heating, while 27.2% in

urban areas use solid fuels for cooking and 90.0% for heating (Central Statistics Organization, 2016). For lighting, a large percentage of the population use kerosene, candles, and gas.

## 5.4 Renewable Energy Potential

Afghanistan has significant renewable energy resources. The estimated hydro-power potential in the country is 23,000 MW, mainly from large dams. Being a “sunbelt” country with 300 sunny days in a year, Afghanistan has the potential to produce up to 220,000 MW solar energy according to a study by the National Renewable Energy Laboratory (NREL) of the United States (Asian Development Bank, 2014). In terms of wind potential, there are large areas in the country, mainly in the western provinces of Nimroz, Farah, Herat, and the north-eastern provinces of Balkh and Takhar, that can produce significant amounts of energy (Fahimi & Upham, 2018). The official estimate for wind potential is 67,000 MW, although there are other sources which quote higher figures (Chaurey et al., 2017; Elliott, 2011). Biomass is another source of energy that is used widely in the country, although in its solid traditional form. However, as per Afghanistan’s Energy Policy of 2015, 4,000 MW of energy can be produced from this source including 3,090 MW from agricultural waste, 840 MW from animal waste, and 91 MW from Municipal Solid Waste (MSW) (Islamic Republic of Afghanistan, Ministry of Energy and Water, 2015a, b). Lastly, the country can also produce energy from its active geothermal systems. These systems are located in the main axis areas of the Hindu Kush Mountains with the surface manifestation in the form of hot springs (Saba et al., 2004). According to the country’s Inter-Ministerial Commission for Energy (ICE), a total of 3,500 MW of energy can be produced from 70 spots that are identified in the Afghanistan Renewable Energy Policy (Inter-ministerial Commission for Energy, 2016). So far, the Ministry of Energy and Water (MEW) with the support of international aid agencies and other governmental agencies have implemented around 5,000 small-scale renewable energy projects (Gencer et al., 2018).

## 5.5 Low-Carbon Energy Targets

The government of Afghanistan in its Renewable Energy Policy of 2015 sets a target for deploying about 4,500 MW of Renewable Energy by 2032. The country’s Power Sector Master Plan (PSMP) of 2013 projects the total energy mix

in 2032 to be 6,000 MW (FICHTNER GmbH & Co. KG, 2013). The country's Renewable Energy Policy estimates that around 95% of the energy supply in 2032 will rely on renewables (Islamic Republic of Afghanistan, Ministry of Energy and Water, 2015a, b). According to calculations by the PSMP, the electrification rate will increase from 30 to 83% in 2032 and the share of locally generated electricity will rise from 20 to 67% (FICHTNER GmbH & Co. KG, 2013).

## 5.6 Challenges to Low-Carbon Energy Transformation

The barrier and factor that overshadows everything in the case of Afghanistan is the lack of security which deters investment in the sector. Regarding its hydro resources which the country relies heavily on it must be said that the use of these waters takes an international dimension since almost all the country's rivers are transboundary. Afghanistan, however, does not have an agreement with these countries except only with Iran. This makes it difficult to develop its hydro resources. Other barriers include "lack of policy clarity and consistency, poor coordination between the stakeholders, shortage of technical capacity, weak grid infrastructure, and climate change and variability" (Fahimi & Upham, 2018, 6).

---

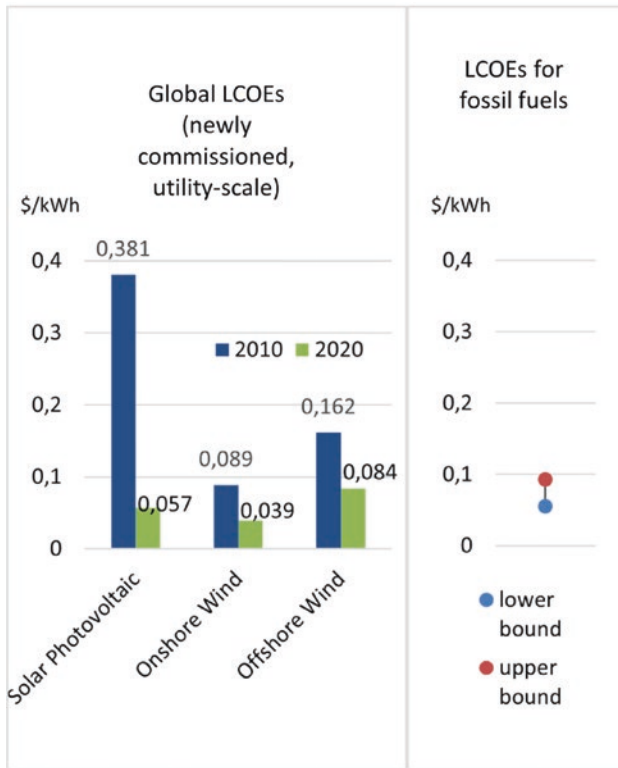
## 6 General Trends and Key Factors in Low-Carbon Energy Transformations

In the following, trends in the energy sector and factors which either facilitate or hinder a successful transition towards carbon-neutrality will be discussed. These have been derived from the previous reviews analysing the energy sectors of China, India, Pakistan, and Afghanistan.

### 6.1 Decreasing Costs of Renewables

Due to economies of scale, technical improvements and accumulated experience, costs of technologies for renewable power generation have fallen sharply in the last decade worldwide. As depicted in Fig. 4, global weighted average levelized costs of electricity for newly commissioned solar photovoltaic (utility-scale) sank by 85.0% from 0.381 USD/kWh in 2010 to only 0.057 USD/kWh in 2020. Costs for newly commissioned onshore wind (utility-scale) dropped by 56.2% from 0.089 USD/kWh in 2010 to 0.039 USD/kWh in 2020, newly commissioned





**Fig. 4** Global LCOEs of different power generation technologies. LCOEs for fossil fuels are based to G20 countries. (Source: IRENA, 2021b)

offshore costs (utility-scale) fell by 48.1% from 0.162 USD/kWh in 2010 to 0.084 USD/kWh in 2020. By reaching these price levels, renewables became competitive with fossil fuel based electricity, whose price level is stated by the International Renewable Energy Agency as 0.055 USD/kWh to 0.148 USD/kWh for newly-built power plants (IRENA, 2021b).

For utility-scale solar PV in China, total costs of 795 2019-USD/kW are stated; for India, total costs of only 618 2019-USD/kW are calculated. For comparison, total costs for Germany are stated with 899 USD-2019/kW (IEA, 2019b). For Pakistan, the International Energy Agency unfortunately doesn't provide any data, but in a trade journal estimated cost for a planned 50 MW project of 900 USD-2019/kW have been reported (Willuhn, 2019).

This trend is also confirmed by the World Energy Outlook 2020, released on 13.10.2020 by the IEA: Estimates for solar electricity costs have decreased by 20–50% compared to the World Energy Outlook 2019. According to the document, LCOEs in the range of only 0.02–0.04 USD/kWh would apply in China and India, where revenue supporting mechanisms (e.g., price guarantees) are implemented. By achieving such low price levels, solar projects in utility-scale are able to beat new coal plants in terms of LCOEs, and are in a similar range with operating costs of present coal plants (Evans & Gabbatiss, 2020; quoted from IEA, 2020g).

## **6.2 Decreasing Dependency on the Import of Fossil Fuels**

As shown above, renewables have not only become cheaper over time, but they also offer many other advantages as well. From a macroeconomic point of view, replacing fossil fuels with renewables capacities can help reduce the dependence on fossil imports. Those saved costs not only help to achieve a more equal balance of trade of a country, but to stop further macroeconomic follow-up effects, such as a possible devaluation of the country's currency which can lead to even increasing costs for imported fossil fuels. The saved costs also allow additional liquidity and therefore investments for renewable capacity and improvements into required infrastructure, for example grids and storage capacities.

## **6.3 Remuneration Schemes**

By switching from administratively set feed-in tariffs (FITs) to competitive auctions, both government and developers can benefit: Provided remuneration schemes are smartly designed, governments can achieve price reductions for the deployment of renewable energy and subsidies. For developers, long-term power purchase agreements (PPAs) allow certainty regarding the remuneration of renewables.

China is transitioning from FITs to competitive auctions. In May 2019, over 20 GW wind and solar projects without subsidies have been permitted by the National Development and Reform Commission (NDRC). Grid operators have been encouraged to sign long-term (20-years) PPAs with developers (IEA, 2019b).

Similarly, in India, due to the introduction of reverse auctions and the resulting increase in competition, a reduction of prices for solar energy has been reached (Burke et al., 2019; Jaiswal et al., 2017).

## 6.4 The Impact of Fossil Fuel Subsidies

In a working paper by the International Monetary Fund, an assessment has been conducted to evaluate price gaps between the retail fossil fuel prices, which consumers are paying and efficient prices for fossil fuel where all externalities (e.g., environmental costs) from the consumption of fossil fuel would have been internalized (Baoping Shang et al., 2019). These effects include the costs resulting of the impact to global warming, the contribution to local air pollution (and resulting consequences like an increased mortality rate) and other negative effects such as congestion and accidents resulting from traffic powered by fossil fuels. According to their approach, (non-)existing fossil fuel price policies resulted in post-tax subsidies of \$ 1,432 billion in China (12.8% of the GDP, or \$ 1,025 per capita) in 2015. For India, post-tax subsidies of \$ 209 billion (10.0% of the GDP, or \$ 160 per capita) emerged in 2015, for Pakistan, post-tax subsidies of \$ 18 billion (6.8% of the GDP, or \$ 97 per capita) appeared in 2015.

These extensive values show the massive distortions due to non-pricing of external effects related to the consumption of fossil fuels and offer at the same time a substantial potential for cost-effective market-based, fiscal, or regulatory instruments to foster the exit from fossil fuels, the cutting of emissions and the support for (or at least not the discrimination against) renewables.

## 6.5 Chinese Influence on Foreign Energy Policies in the Context of the Belt and Road Initiative

China's Belt and Road Initiative has consequences for at least 70 countries, influencing various sectors, such as trade, infrastructure and connectivity (European Bank for Reconstruction and Development, 2020). Coal power plants play a significant role in this context. While the global coal fleet outside of China shrank for the first time since the 1980s from January 2018 to June 2019 by 8.1 GW, China increased its coal capacities in the same period by 42.9 GW (Shearer et al., 2019a). China is not only expanding its national fleet of coal power plants, it is also exporting them in the context of the Belt and Road Initiative to other countries in Asia, Europe and Africa: According to the Institute for Energy Economics and Finan-

cial Analysis, based on a dataset from the Global Coal Plant Tracker, from 399 GW coal capacities under development in January 2019 outside of China, around a quarter (102 GW) have received funding or financial support commitment by financial institutions and corporations from China. For Pakistan, financial aid commitment from China was \$ 2.32 billion for 1.98 GW of coal capacity, plus an additional \$3.606 billion for 7.6 GW of coal capacity (Shearer et al., 2019b).

---

## 7 Discussion and Conclusion

This review set out to provide an overview of the current energy situation in China, India, Pakistan, and Afghanistan, the low-carbon energy targets in these countries, and challenges to and key factors in low-carbon energy transformation. Table 1 gives an overview of previous elaborations.

The crucial question is: Will those efforts be enough to be in line with the Paris climate protection goals?

Analysing the current (first submitted) NDCs of the countries reveals that it will not. No absolute emission reduction targets are provided, instead, for China and India, reduction targets for the emission intensity (decrease of the emissions per GDP unit) are given, which leaves open the possibility of increasing absolute emissions if the gross domestic product of a country increases faster than its emissions. According to the Climate Action Tracker, under the implemented policies of all countries at present, a temperature increase of 2.9 °C is projected until 2100 (Climate Action Tracker, 2020). Even if all countries would fully implement their NDCs, this would result in a temperature rise of 2.8 °C compared to a pre-industrial level (Climate Action Tracker (Climate Analytics, NewClimate Institute, Ecofys), 2016).

The *Stated Policies Scenario* of the World Energy Outlook for China and India has significant higher emissions than allowed to achieve the 1.5/2 °C Paris target. According to the IPCC Special Report from 2018, the remaining Carbon Budget on 1st January 2018 was around 420 GtCO<sub>2</sub> for the ~1.5 °C target and around 1,170 GtCO<sub>2</sub> for the ~2 °C target (IPCC, 2018). China's CO<sub>2</sub> emissions of 9.111 Gt in the *Stated Policies Scenario* in 2040 are almost three times as high as allowed in the *Sustainable Development Scenario* (IEA, 2020g). Applying these findings to coal capacity, the Chinese global coal fleet must be reduced by more than 40% from 1,027 GW in July 2019 to around 600.9 GW in 2030 according to the Global Energy Monitor, to keep global warming well below 2 °C, which is in strong contrast to further expansion plans of the Chinese coal fleet proposed by state-owned enterprises and industry groups (Shearer et al., 2019a).

**Table 1** An overview of low-carbon energy transformation in Afghanistan, China, India, and Pakistan. (Source: Own depiction)

Parameter	Afghanistan	China	India	Pakistan
Population [million] (2021) (World Bank, 2021c)	39.8	1,412.4	1,393.4	225.2
GDP [trillion current USD] (2020) (World Bank, 2020)	0.0198	14,723	2,623	0.264
Electricity consumption per capita [kWh]	186 (year not specified) (Korkovelos et al., 2017b)	5,119 (2019) (IEA, 2021)	987 (2019) (IEA, 2021)	538 (2019) (IEA, 2021)
CO <sub>2</sub> emissions per capita [t] (2018) (World Bank, 2021b)	0.2	7.4	1.8	1.0
Total CO <sub>2</sub> emissions [Mt] (2018) (World Bank, 2021a)	7.4	10,313.5	2,434.5	208.4
Prospects, based on 2016 NDCs	<p>By 2030:</p> <ul style="list-style-type: none"> <li>• Reduce GHG emissions by 13.6% to a business as usual 2030 scenario, conditional on external support. (Islamic Republic of Afghanistan, 2015a, 2015b)</li> </ul>	<p>By 2030:</p> <ul style="list-style-type: none"> <li>• Achieve peak of carbon dioxide emissions</li> <li>• Reduce CO<sub>2</sub> emissions per GDP unit by 60–65% compared to 2005</li> <li>• Raise share of non-fossil fuels in primary energy consumption to 20%</li> <li>• Increase forest stock volume increase by 4.5 billion m<sup>3</sup> compared to 2005 (Government of People's Republic of China, 2015)</li> </ul>	<p>By 2022:</p> <ul style="list-style-type: none"> <li>• Achieve 60 GW wind energy capacity</li> <li>• Achieve 100 GW solar energy capacity</li> <li>• Achieve 10 GW biomass energy capacity</li> </ul> <p>By 2032:</p> <ul style="list-style-type: none"> <li>• Achieve 63 GW nuclear energy capacity</li> </ul> <p>From 2021 to 2030:</p> <ul style="list-style-type: none"> <li>• Reduce the emission intensity of its GDP by 33–35% by 2030 from 2005 level</li> <li>• Achieve a share of 40% electric power installed capacity from non-fossil fuels by 2030</li> <li>• Create additional carbon sink of 2.5 - 3 billion tonnes of CO<sub>2</sub> equivalents through additional forest and tree cover by 2030. (Government of India, 2016)</li> </ul>	<p>By 2025:</p> <ul style="list-style-type: none"> <li>• Add 25 GW capacity to the national grid (Government of Pakistan, 2016)</li> </ul>

Similarly, in India, projected emissions in the *Stated Policies Scenario* are about 2.3 times as high as permitted in the *Sustainable Development Scenario*.

For Pakistan and Afghanistan, ending the ongoing energy shortages and the energy supply–demand gap have priority. However, by making the choice now through investments into renewable instead of conventional fuel-based energy, the countries have the chance to make use of its abundant resources, avoiding lock-in effects into conventional energy and reducing its dependency from expensive energy imports.

All countries are equipped with abundant renewable energy resources. As renewables have become cheaper and cheaper, they nowadays not only provide massive ecological, but also economic advantages in comparison to coal, oil, and gas. Grid infrastructure often remains a bottleneck in these countries to transfer clean energy to its consumers. By setting the right course now, through the stop of building new coal power plants, the provision of both attractive and efficient remuneration schemes for renewables and an ongoing expansion of grid and storage infrastructure, these countries could reduce emissions and pollutants from the combustion of fuels significantly, decrease their costs for expensive energy imports, and provide a green, cost-efficient, and reliable power supply.

---

## References

- Asian Development Bank. (2014). *Technical Assistance Report: Islamic Republic of Afghanistan: Renewable Energy Development, Project Number 47266-001.* Manila, Philippines. <https://www.adb.org/sites/default/files/project-document/151922/47266-001-tar.pdf>.
- Baloch, M. H., Chauhdary, S. T., Ishak, D., Kaloi, G. S., Nadeem, M. H., Wattoo, W. A., Younas, T., & Hamid, H. T. (2019). Hybrid energy sources status of Pakistan: An optimal technical proposal to solve the power crises issues. *Energy Strategy Reviews*, 24(April), 132–153. <https://doi.org/10.1016/j.esr.2019.02.001>
- Shang, B., Le, N. P., Parry, I., & Coady, M. D. (2019). *Global fossil fuel subsidies remain large: An update based on country-level estimates.* <https://www.imf.org/~media/Files/Publications/WP/2019/WPIEA2019089.ashx>.
- Burandt, T., Xiong, B., Löffler, K., & Oei, P.-Y. (2019). Decarbonizing China's energy system—modeling the transformation of the electricity, transportation, heat, and industrial sectors. *Applied Energy*, 255, 113820. <https://doi.org/10.1016/j.apenergy.2019.113820>
- Burke, P. J., Widnyana, J., Anjum, Z., Aisbett, E., Resosudarmo, B., & Baldwin, K. G. H. (2019). Overcoming barriers to solar and wind energy adoption in two Asian giants: India and Indonesia. *Energy Policy*, 132, 1216–1228. <https://doi.org/10.1016/j.enpol.2019.05.055>
- Central Electricity Authority, Ministry of Power. (2020). *“All India installed capacity (in MW) of power stations.”* [https://cea.nic.in/reports/monthly/installedcapacity/2020/installed\\_capacity-08.pdf](https://cea.nic.in/reports/monthly/installedcapacity/2020/installed_capacity-08.pdf).

- Central Statistics Organization. (2016). “*Afghanistan at a glance: 2015–2016*.” Kabul, Afghanistan.
- Chaurey, A., Narasimhan, G., Chatterjee, A., Fazli, F., Musleh, A. J., Haseib, M., Shinwari, E. S. (2017). “Renewable energy roadmap 2032: TA-8808 AFG: Renewable energy development in Afghanistan.” Asian Development Bank; IT Power Consulting Private Limited.
- Climate Action Tracker. (2020). “Warming projections global update–September 2020.” <https://climateactiontracker.org/publications/global-update-pandemic-recovery-with-just-a-hint-of-green/>.
- Climate Action Tracker (Climate Analytics, NewClimate Institute, Ecofys). (2016). “Paris agreement in force, but no increase in climate action.” [https://climateactiontracker.org/documents/48/CAT\\_2016-11-10\\_TemperatureUpdateNov16\\_CATUpdate.pdf](https://climateactiontracker.org/documents/48/CAT_2016-11-10_TemperatureUpdateNov16_CATUpdate.pdf).
- Elliott, D. (2011). “Wind resource assessment and mapping for Afghanistan and Pakistan.” National Renewable Energy Laboratory (NREL). Golden, Colorado, USA. [https://pdf.usaid.gov/pdf\\_docs/PNADO338.pdf](https://pdf.usaid.gov/pdf_docs/PNADO338.pdf).
- European Bank for Reconstruction and Development. (2020). “Belt and road initiative (BRI).” <https://www.ebrd.com/what-we-do/belt-and-road/overview.html>. Accessed: 18 Oct 2020
- Evans, S. & Gabbatiss, J. (2020). “Solar is now ‘cheapest electricity in history’, confirms IEA.” CarbonBrief. <https://www.carbonbrief.org/solar-is-now-cheapest-electricity-in-history-confirms-iea>. Accessed: 13 Oct 2020
- Fahimi, A., & Upham, P. (2018). The renewable energy sector in Afghanistan: Policy and potential. *Wiley Interdisciplinary Reviews: Energy and Environment*, 7(2), e280. <https://doi.org/10.1002/wene.280>
- FICHTNER GmbH & Co. KG. (2013). “Islamic republic of Afghanistan: Power sector master plan, TA-7637 (AFG).” Asian Development Bank. Manila, Philippines. <https://www.adb.org/sites/default/files/project-document/76570/43497-012-afg-tacr.pdf>.
- Gencer, Defne, John Irving, Peter Meier, Richard Spencer, and Chris Wnuk. (2018). “Energy security trade-offs under high uncertainty: Resolving Afghanistan’s power sector development dilemma.” International Bank for Reconstruction and Development/The World Bank. Washington, DC. <https://www.esmap.org/sites/default/files/esmap-files/Uncertainty-OKR-R1.pdf>.
- Global Solar Atlas 2.0. (2019a). “Photovoltaic power potential–China.” <https://globalsolaratlas.info/download/china>.
- Global Solar Atlas 2.0. (2019b). “Photovoltaic Power Potential–India.” <https://globalsolaratlas.info/download/india>.
- Global Solar Atlas 2.0. 2019c. “Photovoltaic power potential–Pakistan.” <https://globalsolaratlas.info/download/pakistan>.
- Global Solar Atlas 2.0. 2021. “Global solar atlas 2.0.” 2021. <https://globalsolaratlas.info/map>.
- Global Wind Atlas 3.0. (2021a). “China.” 2021a. <https://globalwindatlas.info/area/China>.
- Global Solar Atlas 2.0. (2021b). “India.” 2021b. <https://globalwindatlas.info/area/India>.
- Global Solar Atlas 2.0. (2021c). “Pakistan.” 2021c. <https://globalwindatlas.info/area/Pakistan>.
- Government of India. (2016). “India First NDC.” <https://www4.unfccc.int/sites/ndcstaging/PublishedDocuments/India%20First/INDIA%20INDC%20TO%20UNFCCC.pdf>.

- Government of Pakistan. (2016). "Pakistan's intended nationally determined contribution (PAK-INDC)." <https://www4.unfccc.int/sites/ndcstaging/PublishedDocuments/Pakistan%20First/Pak-INDC.pdf>.
- Government of People's Republic of China. (2015). "China's first NDC submission." Bonn. <https://www4.unfccc.int/sites/ndcstaging/PublishedDocuments/China%20First/China's%20First%20NDC%20Submission.pdf>.
- IEA. (2018a). "Data & statistics. Energy topic: CO<sub>2</sub> emissions, indicator: CO<sub>2</sub> emissions per capita, Country: India." 2018a. <https://www.iea.org/data-and-statistics?country=INDIA&fuel=CO2%20emissions&indicator=CO2PerCap>.
- IEA. (2018b). "Data & statistics. Energy topic: CO<sub>2</sub> emissions, indicator: CO<sub>2</sub> emissions per capita, Country: Pakistan." 2018b. <https://www.iea.org/data-and-statistics?country=PAKISTAN&fuel=CO2%20emissions&indicator=CO2>.
- IEA. (2018c). "Data & statistics. Energy topic: CO<sub>2</sub> emissions, indicator: Total CO<sub>2</sub> emissions, country: Pakistan." 2018c. <https://www.iea.org/data-and-statistics?country=PAKISTAN&fuel=CO2%20emissions&indicator=TotCO2>.
- IEA. (2018d). "Data & statistics. Energy topic: CO<sub>2</sub> emissions, indicator: Total CO<sub>2</sub> emissions, Country: World." 2018d. <https://www.iea.org/data-and-statistics/data-browser/?country=WORLD&fuel=CO2%20emissions&indicator=TotCO2>.
- IEA. (2019a). "Data & statistics. Energy topic: CO<sub>2</sub> emissions, indicator: Total CO<sub>2</sub> emissions, Country: India." 2019a. <https://www.iea.org/data-and-statistics?country=INDIA&fuel=CO2%20emissions&indicator=TotCO2>.
- IEA. (2019b). *Renewables 2019: Analysis and forecasts to 2024*. International Energy Agency. <https://doi.org/10.1787/b3911209-en>
- IEA. (2020a). "China-key energy statistics." 2020a. <https://www.iea.org/countries/china>.
- IEA. (2020b). "Data & statistics. Data tables. Energy category: Balances, Country: Pakistan, Year: 2018." 2020b. <https://www.iea.org/data-and-statistics/data-tables?country=PAKISTAN&energy=Balances&year=2018>.
- IEA. (2020c). "Data & statistics. Energy topic: CO<sub>2</sub> emissions, indicator: CO<sub>2</sub> Emissions per capita, Country: China (People's Republic of China and Hong Kong China)." 2020c. <https://www.iea.org/data-and-statistics?country=CHINAREG&fuel=CO2%20emissions&indicator=CO2PerCap>.
- IEA. (2020d). "India-Key Energy Statistics." 2020d. <https://www.iea.org/countries/India>.
- IEA. (2020e). "Pakistan-key energy statistics." 2020e. <https://www.iea.org/countries/pakistan>.
- IEA. (2020f). "India 2020f-Energy policy review." <https://www.iea.org/reports/india-2020f>.
- IEA. (2020g). "World energy outlook 2020g." Paris. <https://webstore.iea.org/world-energy-outlook-2020g>.
- IEA. (2021). "Key world energy statistics 2021." <https://iea.blob.core.windows.net/assets/52f66a88-0b63-4ad2-94a5-29d36e864b82/KeyWorldEnergyStatistics2021.pdf>.
- Inter-ministerial Commission for Energy. (2016). "Afghanistan energy sector update." Ministry of Economy: Inter-ministerial Commission for Energy. Main Conference Hall. Retrieved from <https://sites.google.com/site/iceafghanistan/>.
- IPCC. (2018). "IPCC, 2018: Global warming of 1.5°C. An IPCC special report on the impacts of global warming of 1.5°C above pre-industrial levels and related global greenhouse gas emission pathways, in the context of strengthening the global response to the threat of climate change, sustainable development, and efforts to eradicate poverty. [Masson-Delmotte, V., P. Zhai, H.-O. Pörtner, D. Roberts, J. Skea, P.R. Shukla,



- A. Pirani, W. Moufouma-Okia, C. Péan, R. Pidcock, S. Connors, J.B.R. Matthews, Y. Chen, X. Zhou, M.I. Gomis, E. Lonnoy, T. Maycock, M. Tignor, and T. Waterfield (Eds.]. In Press.” [https://www.ipcc.ch/site/assets/uploads/sites/2/2019/06/SR15\\_Full\\_Report\\_High\\_Res.pdf](https://www.ipcc.ch/site/assets/uploads/sites/2/2019/06/SR15_Full_Report_High_Res.pdf).
- IRENA. (2021a). “Renewable capacity statistics 2021a.” <https://www.irena.org/publications/2021a/March/Renewable-Capacity-Statistics-2021>.
- IRENA. (2021b). “Renewable power generation costs in 2020.” <https://www.irena.org/publications/2021b/Jun/Renewable-Power-Costs-in-2020>.
- Islamic Republic of Afghanistan. (2015a). “Intended nationally determined contribution submission to the United Nations framework convention on climate change.” [https://www4.unfccc.int/sites/ndcstaging/PublishedDocuments/Afghanistan%20First/INDC\\_AFG\\_2015a0927\\_FINAL.pdf](https://www4.unfccc.int/sites/ndcstaging/PublishedDocuments/Afghanistan%20First/INDC_AFG_2015a0927_FINAL.pdf).
- Islamic Republic of Afghanistan, Ministry of Energy and Water. (2015b). “Renewable energy policy.” <https://policy.asiapacificenergy.org/sites/default/files/Afghanistan-Renewable-Energy-Policy-English-and-Dari.pdf>.
- Jaiswal, S., Jain, A., Orlandi, I., & Sethia, A. (2017). “Accelerating India’s clean energy transition.” Bloomberg New Energy Finance. [https://data.bloomberglp.com/professional/sites/10/BNEF\\_Accelerating-Indias-Clean-Energy-Transition\\_Nov-2017.pdf](https://data.bloomberglp.com/professional/sites/10/BNEF_Accelerating-Indias-Clean-Energy-Transition_Nov-2017.pdf).
- Korkovelos, A., Bazilian, M., Mentis, D., & Howells, M. (2017a). “A GIS approach to planning electrification in Afghanistan. Live wire.” World Bank. <https://openknowledge.worldbank.org/handle/10986/29140>.
- Korkovelos, A., Bazilian, M., Mentis, D., & Howells, M. (2017b). “Afghanistan energy study - a GIS approach to planning electrification in Afghanistan.” [https://energypedia.info/images/d/d6/A\\_GIS\\_approach\\_to\\_electrification\\_planning\\_in\\_Afghanistan.pdf](https://energypedia.info/images/d/d6/A_GIS_approach_to_electrification_planning_in_Afghanistan.pdf).
- Ministry of New and Renewable Energy, Government of India. (2020). “Green Energy Corridor | Ministry of New and Renewable Energy, Government of India.” <https://mnre.gov.in/green-energy-corridor>. Accessed: 16 Oct 2020
- National Bureau of Statistics of China. (2021a). “China statistical yearbook 2020: 9–1 total primary energy production and its composition.” 2021a. <http://www.stats.gov.cn/tjsj/ndsj/2019/indexeh.htm>.
- National Bureau of Statistics of China. (2021b). “China statistical yearbook 2020: 9–2 total energy consumption and its composition.” 2021b. <http://www.stats.gov.cn/tjsj/ndsj/2020/indexeh.htm>.
- National Bureau of Statistics of China. (2021c). “China statistical yearbook 2020: 9–15 installed capacity of power generation.” 2021c. <http://www.stats.gov.cn/tjsj/ndsj/2020/indexeh.htm>.
- National Electric Power Regulatory Authority. (2019). “2018–2019 annual report.” Islamabad. <https://nepra.org.pk/publications/Annual%20Reports/Annual%20Report%202018-19.pdf>.
- Nicholas, S. & Buckley, T. (2018). “Pakistan’s power future.” Institute for energy economics and financial analysis. [http://ieefa.org/wp-content/uploads/2018/11/Pakistans-Power-Future\\_December-2018.pdf](http://ieefa.org/wp-content/uploads/2018/11/Pakistans-Power-Future_December-2018.pdf).
- Ramakrishnan, A., Kalkuhl, M., Ahmad, S., & Creutzig, F. (2020). Keeping up with the patels: Conspicuous consumption drives the adoption of cars and appliances in India. *Energy Research & Social Science*, 70, 101742. <https://doi.org/10.1016/j.erss.2020.101742>

- Saba, D. S., Najaf, M. E., Musazai, A. M., & Taraki, S. A. (2004). "Geothermal energy in Afghanistan: Prospects and potential; prepared for center on international cooperation, New York University." Afghanistan Center for Policy and Development Studies.
- Shah, S. A. A. & Solangi, Y. A. (2019). "A sustainable solution for electricity crisis in Pakistan: opportunities, barriers, and policy implications for 100% renewable energy." *Environmental Science and Pollution Research*, 26 (29), 29687–703. <https://doi.org/10.1007/s11356-019-06102-0>.
- Shearer, C., Brown, M., & Buckley, T. (2019a). "China at a crossroads: Continued support for coal power erodes country's clean energy leadership." Institute for Energy Economics and Financial Analysis. [https://ieefa.org/wp-content/uploads/2019a/01/China-at-a-Crossroads\\_January-2019a.pdf](https://ieefa.org/wp-content/uploads/2019a/01/China-at-a-Crossroads_January-2019a.pdf).
- Shearer, C., Yu, A., & Nace, T. (2019b). "Out of step: China is driving the continued growth of the global coal fleet." Global Energy Monitor. <https://endcoal.org/wp-content/uploads/2019b/11/Out-of-Step-English-final.pdf>.
- Stacey, K. (2018). "Pakistan's pivot to coal to boost energy gets critics fired up." *Financial Times*. <https://www.ft.com/content/5cd07544-7960-11e8-af48-190d103e32a4>. Accessed: 31 July 2018.
- United Nations. (2020). "Goal 7 | Department of economic and social affairs." <https://sdgs.un.org/goals/goal7>. Accessed: 2020.
- United Nations Development Programme. (2019). *Human Development Report 2019: Beyond Income, beyond Averages, beyond Today: Inequalities in Human Development in the 21st Century*.
- Willuhn, M. (2019). "Pakistan's Nepra Mulls another 50 MW of solar – Pv magazine international." <https://www.pv-magazine.com/2019/08/30/pakistans-nepra-mulls-another-50-mw-of-solar/>. Accessed: 30 Aug 2019
- World Bank. (2016a). "Afghanistan country snapshot." <http://documents1.worldbank.org/curated/en/584381476781571691/pdf/109246-WP-AfghanistanCountrySnapshots-high-res-PUBLIC.pdf>.
- World Bank. (2016b). "CO<sub>2</sub> emissions (Kt) - Afghanistan | Data." 2016b. <https://data.worldbank.org/indicator/EN.ATM.CO2E.KT?locations=AF>.
- World Bank. (2020). "GDP (Current US\$) | Data." 2020. <https://data.worldbank.org/indicator/NY.GDP.MKTP.CD>.
- World Bank. (2021a). "CO<sub>2</sub> emissions (Kt) | Data." 2021a. <https://data.worldbank.org/indicator/EN.ATM.CO2E.KT>.
- World Bank. (2021b). "CO<sub>2</sub> emissions (Metric Tons per Capita) | Data." 2021b. <https://data.worldbank.org/indicator/EN.ATM.CO2E.PC>.
- World Bank. (2021c). "Population 2021." <https://databank.worldbank.org/data/download/POP.pdf>.
- Xinhua News Agency, translated on behalf of Center for Security and Emerging Technology (CESET). (2021). "Outline of the People's Republic of China 14th five-year plan for National Economic and Social Development and Long-Range Objectives for 2035." [https://cset.georgetown.edu/wp-content/uploads/t0284\\_14th\\_Five\\_Year\\_Plan\\_EN.pdf](https://cset.georgetown.edu/wp-content/uploads/t0284_14th_Five_Year_Plan_EN.pdf).

**Open Access** This chapter is licensed under the terms of the Creative Commons Attribution 4.0 International License (<http://creativecommons.org/licenses/by/4.0/>), which permits use, sharing, adaptation, distribution and reproduction in any medium or format, as long as you give appropriate credit to the original author(s) and the source, provide a link to the Creative Commons license and indicate if changes were made.

The images or other third party material in this chapter are included in the chapter's Creative Commons license, unless indicated otherwise in a credit line to the material. If material is not included in the chapter's Creative Commons license and your intended use is not permitted by statutory regulation or exceeds the permitted use, you will need to obtain permission directly from the copyright holder.





# Consequences of Lockdown Due to COVID-19 on the Electricity Generation and Environment in South Asia

Shameem Hasan, Mirza Rasheduzzaman and M. Mofazzal Hossain

## Abstract

There has been an unprecedented impact of COVID-19 outbreak worldwide. To save people from COVID-19, many countries imposed strict lockdown since March 2020 in different phases. In this paper, the impacts of COVID-19 on the power industry of Bangladesh, India and Sri Lanka and its positive impacts on the environment have been investigated through the reduction of power generation and Green House Gas (GHG) emission during a certain part of the lockdown period. It is found that there was a 16.96%, 26% and 22.7% reduction of power generation in May'20 compared with that of May'19 in Bangladesh, India, and Sri Lanka respectively. Carbon dioxide (CO<sub>2</sub>), Sulphur dioxide (SO<sub>2</sub>), Nitrogen oxides (NO<sub>x</sub>) and fluorinated gases are the main components of Green House Gases (GHGs) where CO<sub>2</sub> contains almost 80% of the GHGs. CO<sub>2</sub> emission was reduced by a maximum of 22.29% in May

---

S. Hasan (✉)

Department of Electrical and Electronic Engineering, Ahsanullah  
University of Science and Technology, Dhaka, Bangladesh  
e-mail: [shameemhasan.eee@aust.edu](mailto:shameemhasan.eee@aust.edu)

M. Rasheduzzaman · M. M. Hossain

Department of Electrical and Electronic Engineering, University of Liberal Arts  
Bangladesh, Dhaka, Bangladesh  
e-mail: [mirza.rasheduzzaman@ulab.edu.bd](mailto:mirza.rasheduzzaman@ulab.edu.bd)

M. Mofazzal Hossain

e-mail: [mofazzal.hossain@ulab.edu.bd](mailto:mofazzal.hossain@ulab.edu.bd)

© The Author(s) 2023

S. Groh et al. (eds.), *Electricity Access, Decarbonization, and Integration of Renewables*, Energiepolitik und Klimaschutz. Energy Policy and Climate Protection, [https://doi.org/10.1007/978-3-658-38215-5\\_6](https://doi.org/10.1007/978-3-658-38215-5_6)

113

2020 in Bangladesh compared to May'19. India encountered a CO<sub>2</sub> emission reduction of 29.75% in April'20 compared to April'19. NO<sub>x</sub> and SO<sub>2</sub> reduction in India in April'20 were 29.59% and 31.19% respectively whereas in Bangladesh in May'20 during the lockdown, NO<sub>x</sub> decreased by 15.57% and SO<sub>2</sub> increased by 23.36%. Hence, from the comparative study presented in this paper, the consequence of lockdown due to COVID-19 on the power sector and environment of three South Asian countries can be realized.

---

**Keywords**

COVID-19 · Clean Energy · Carbon dioxide · Coal · Environment · Fossil Fuel · Greenhouse gas emission

---

## 1 Introduction

The coronavirus disease 2019 (COVID-19) pandemic has severely impacted every span of life and cornered the technological advancement globally. The most advanced countries except China are among the deadly affected countries. Meanwhile, thousands of lives are lost, and pandemic had a short term and a long-term impact on the global health services, education system, economy, airlines transportation system, and social interaction. Since January 2020, governments in many countries have shut down all educational institutions, shopping malls, industries, airlines, recreation facilities including beaches, sporting facilities and both public and private offices due to the outbreak of COVID-19. In emergency cases, both public and private offices including banks were run by a slim number of staffs. However, pandemic has positive impacts on e-commerce, ICT (information and communication technology) business, global warming due to greenhouse gas emission due to the restricted movement of people. As electricity is the key to the modern ICT based lifestyle; therefore, to assess the positive and negative impacts of this pandemic on the global economy, industry, business, daily life, and natural environment, one of the most important indicators is electricity consumption. The consumption of electricity is a very crucial indicator in evaluating any kind of economic development or disaster or living standard (Yoo & Lee, 2010, 622) (Grottere et al., 2018, 877). Recently, several research works have been carried out on the impacts of COVID-19 on the power and energy sector. The impacts of lower supply and demand on the electricity market and greenhouse gas (GHG) emission have been analysed by Zhong et al (Zhong et al., 2020). Gillingham et al investigated the short-term effects such as

reduction of CO<sub>2</sub>, air pollution as well as the long-term effects such as investment in electricity generation from renewable energy sources (Gillingham et al., 2020, 1337). According to Hosseini, there has been a significant reduction in the implementation of sustainable energy technology due to the impacts of COVID-19 on renewable energy manufacturing facilities and supply chains (Hosseini, 2020, 101633). Abu-Rayash et al reported that in China there was an estimated CO<sub>2</sub> emission reduction of approximately 25% in February 2020 compared with the same month in 2019 due to the lockdown in industrial sector (Abu-Rayash & Dincer, 2020, 101682). Quéré et al reported that the daily average global CO<sub>2</sub> emission reduction was 17% in April 2020 compared with April 2019 (Le Quéré et al., 2020, 647). However, these are short-term effects; these studies will help the policy makers planning the electricity generation from renewable and sustainable energy sources.

All the above studies on the impacts of COVID-19 have been conducted based on the data from developed countries. The most highly densely populated countries in the world are India, Bangladesh, and Sri Lanka. Therefore, the aim of this work is to study the impacts of COVID-19 for these developing countries, which were moderately affected by COVID-19 during April to July 2020. During to the COVID-19 outbreak, the educational, industrial, and commercial, infrastructure were completely under shutdown from March to June 2020. Every occurrence in nature has two types of impacts—constructive and destructive. The destructive consequence is that it took the lives of thousands of people globally. On the contrary, the COVID-19 has also several constructive impacts. It recovered the polluted environment a lot by reducing GHG emission. About 75% of India's electricity is still generated from fossil fuels, meaning the country has one of the world's dirtiest electricity systems. The power sector is also responsible for 50% of India's CO<sub>2</sub> emissions (Carbon Brief, 2020). In Bangladesh, the most vulnerable sector of CO<sub>2</sub> emission is the electrical power generation plants because most of the power plants (98%) are fossil fuel (coal, gas, and oil) based, and are responsible for around 52% of CO<sub>2</sub> emissions (Options for Carbon Tax in Bangladesh 2018) (BPDB, 2020). The demand for electricity has been increasing every year in these countries; and as a result, the GHG emission from this sector has been increasing with an annual average rate of 8.8% per year (World Bank Group, 2018). The power sector of Bangladesh is responsible for 44% of total carbon emission in the country in 2016. Despite the significant contribution of power sector in CO<sub>2</sub> emission on the environment, there is no established global mechanism for the estimation of emission data on a real time basis, only yearly data are available. In Bangladesh, data of daily electricity generation, types of primary energy sources used, and the electricity demand are available from the

official website of PGCB (Power Grid Company Bangladesh) (PGCB, 2020). Unfortunately, there was no effort from the researchers' side for the quantitative analysis of total CO<sub>2</sub> emission from the power generation plants of Bangladesh. Mondal et al investigated for appropriate electricity generation technologies with reduced CO<sub>2</sub> emission targets and carbon tax for the period of 2005–2035 for the power sector of Bangladesh. They also apprehended that solar PV may play an important role in achieving sustainable energy security (Mondal et al., 2010, 4902). However, from the daily/monthly electricity generation data, the estimation of CO<sub>2</sub> and GHG emission for different primary energy sources (mainly fossil fuel) is yet to be done.

In this article, it is aimed to briefly describe the electricity generation scenarios of India, Bangladesh, and Sri-Lanka (types of primary energy sources and technologies), and to estimate the peak GHG emission reduction due to restriction and lockdown during the period of March to July 2019 and 2020. Comparing these estimated data, a quantitative analysis of the impacts of COVID-19 on the environment and power sector of these countries will be presented.

---

## 2 Current Scenario of Power Sector of Bangladesh, India, and Sri Lanka

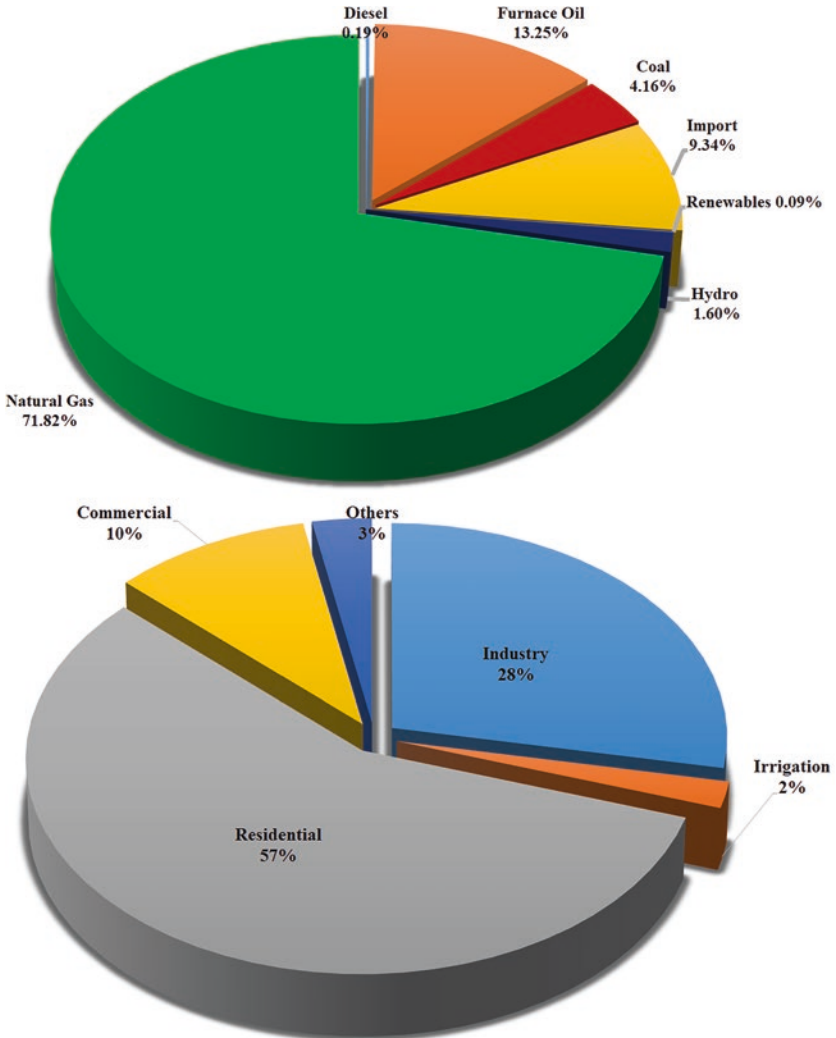
At present the electricity generation plants in Bangladesh are controlled by BPDB (Bangladesh Power Development Board), six other government owned companies (Ashugang Power Station Co Ltd, North West Power Generation Co Ltd, Electricity Generation Company of Bangladesh, Coal Power Generation Co. Bangladesh Ltd, Rural Power Company Ltd, B-R Power Generation Ltd) and several IPPs (Independent Power Producers) and SIPPs (Small Independent Power Producers). The generated power is fed to the national grid. The transmission system plays an important role in the power delivering system by making a link between the generating plants and the distribution systems. The power transmission throughout the country is solely controlled by Power Grid Company Bangladesh (PGCB), which is a public limited company. Finally, the distribution system supplies the electricity to the consumers. There are six distribution companies—Bangladesh Rural Electrification Board (BREB), Dhaka Power Distribution Company (DPDC), Dhaka Electricity Supply Company (DESCO), Northern Electricity Supply Co. Ltd (NESCO), West Zone Power Distribution Co. Ltd (WZPDCL) and Bangladesh Power Development Board (BPDB). BPDB works as a single buyer in the power market of Bangladesh. BPDB purchases electricity from the public and private generation entities and sells bulk electricity to all the distri-

bution utilities including its four distribution zones (Chattogram 3 distribution zone, Mymensingh distribution zone, Cumilla distribution zone and Sylhet distribution zone). The distribution entities that purchase electricity from BPDB are as follows: Dhaka Power Distribution Company (DPDC), Dhaka Electric Supply Company (DESCO), West Zone Power Distribution Company Ltd (WZPDCL), Bangladesh Rural Electrification Board (BREB), Northern Electricity Supply Company Ltd (NESCO) and BPDB's four distribution zones. Almost 50% of electrical power of Bangladesh is distributed by BREB which mainly distributes power in the rural areas (Hasan et al., 2021).

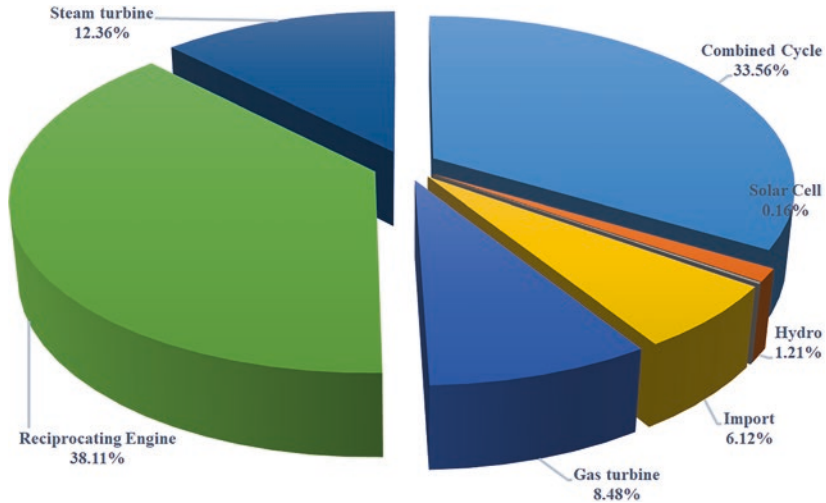
In Bangladesh, as on October 2020, the total system installed capacity was 23548 MW (including Captive and Renewable), which includes 9,717 MW from public sector, 8,884 MW from private sector, 662 MW PPP, 1,160 MW imported from India and 365 MW renewable and 2,800 MW from off-grid captive power plants (BPDB, 2020). The total electricity generation in the fiscal year 2019–2020, was 71419 GWh (BPDB, 2020). The total energy generated in the 2019–2020 fiscal year (both in public and private sector power plants) by type of fuel are shown in Fig. 1. At present, the total transmission and distribution loss in Bangladesh is 11.23% (BPDB, 2020). Based on the standard emission factors for different types of fossil fuels, it is possible to calculate the GHG emission for per MWh energy production from different types of power plants. The technology-based capacity of Bangladesh is shown in Fig. 2. Though the pie chart in Fig. 2 is showing 0.16% solar energy supply capacity but recently, Government of Bangladesh has setup some solar-based power plants (i. e., 73 MW solar power plant at Mymensingh, 35 MW solar power plant at Pabna, 7.4 MW solar power plant at Kaptai etc.). There are 36 solar parks in Bangladesh with a rated electricity generation capacity of 2110.56 MW (National Database of Renewable Energy, 2021).

In India, the production of electricity is mostly achieved through coal thermal power plants. The government of India is focusing on electricity production from renewable energies, but as of now, coal remains the dominant source of electricity in the country. Energy generation from different sources and consumption in different sectors for India is shown in Fig. 3. Since 2000, the percentage production of electricity from coal has been increasing and now has increased to 73% (World Bank database, 2021). In 2019, India generated 356100.19 MW comprising of Thermal 226279.34 MW (63.54%), Hydro 45399.22 MW (12.75%), Nuclear 6780.00 MW (1.9%) and Renewable Energy generation from different sources and consumption in different sectors for India is shown in Fig. 3. (Energy Sources (RES) 77641.63 MW (21.8%) (CEA, 2019). Renewable electricity in the form of solar, wind, biomass, and small hydropower with a capacity of less than 25 MW plants are progressing. Non-utilities or independent power producers have also





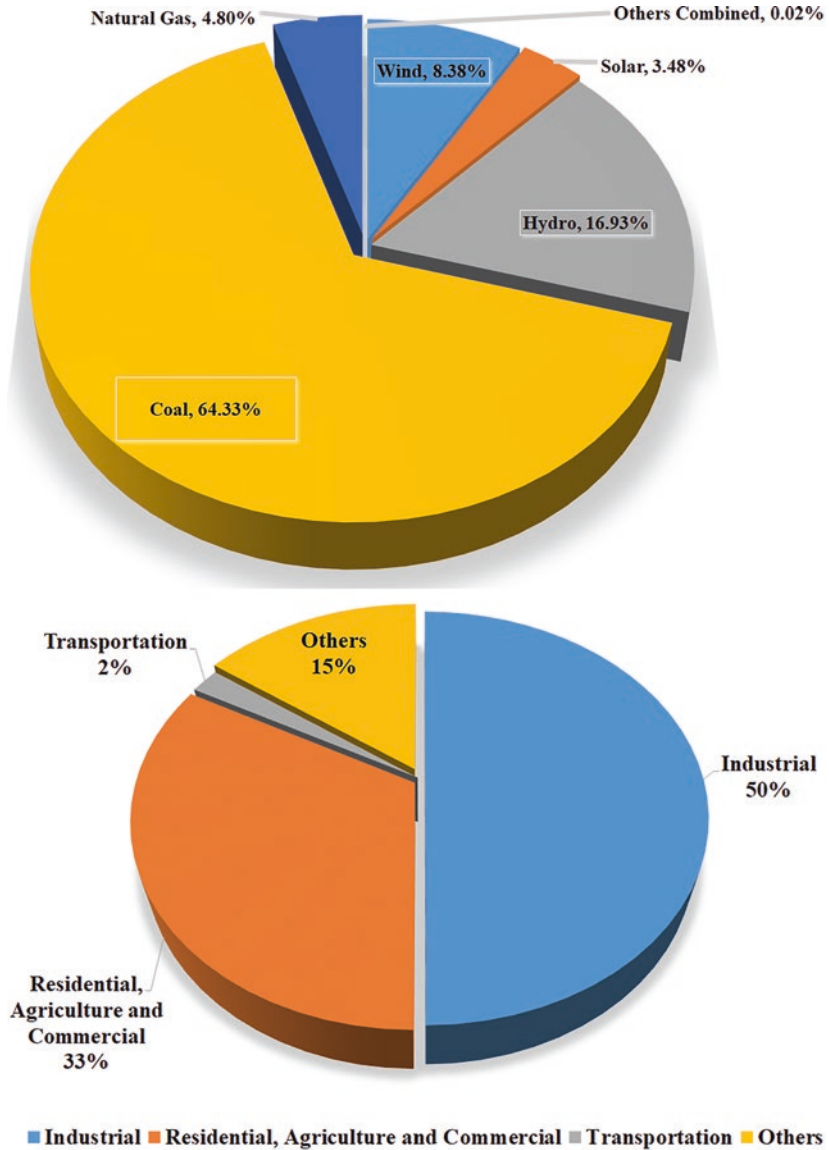
**Fig. 1** Energy generation from different sources and consumption in different sectors for Bangladesh. (Source: BPDB, 2020 and PGCB, 2020)



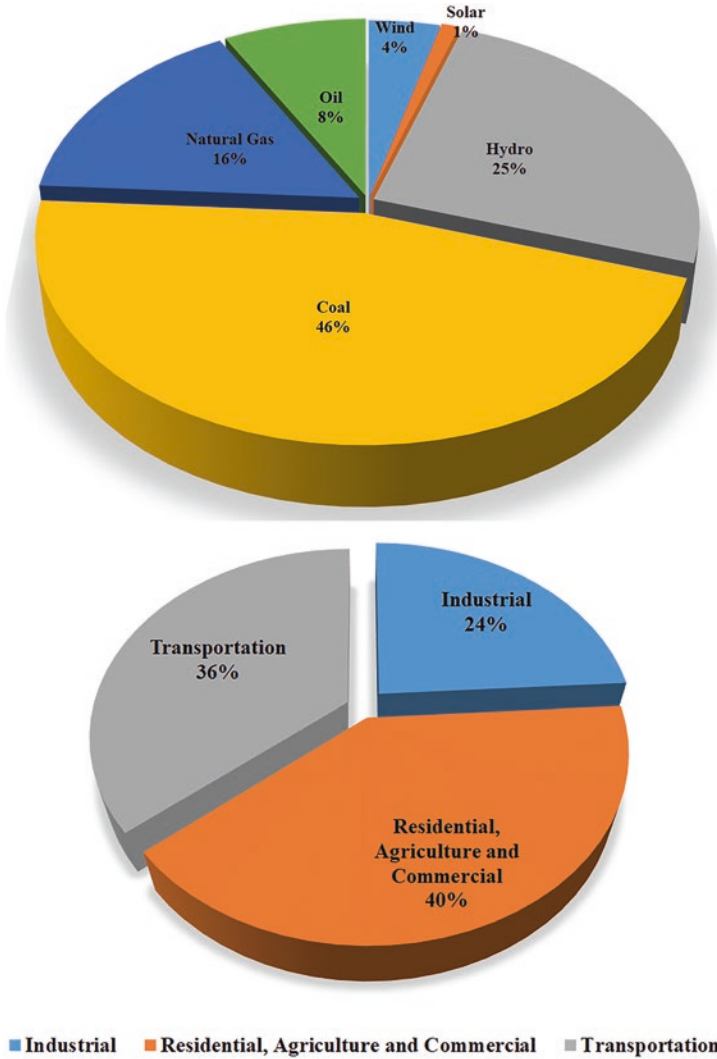
**Fig. 2** Technology-based Capacity in Bangladesh. (Source: BPDB, 2020)

been growing at a rate of 10% over the years (Energy Statistics, 2019). The consumption of electricity is 1209972 GWh during the year 2018–19 in India. The length of transmission and distribution lines is 12682649 ckt. -km.

Sri Lanka's primary power generation sources were oil (23.6%) and coal (31%) in 2017. Almost 40% of Sri Lanka's electricity came from hydropower in 2018 but coal's shares in power generation have been increasing since 2010. At present coal is the most dominating energy source of Sri Lanka. Fig. 4 shows the percentage contribution of different sources in the power generation of Sri Lanka. The maximum electricity demand is 2,616.10 MW in the year 2018. Sri Lanka has hydropower, thermal power and solar, Biomass and wind power with an installed capacity of 1793 MW, 2037 MW and 216 MW respectively. In the case of sector-wise CO<sub>2</sub> production, transport produced 48.5% and electricity and heat produced 38.84% in 2018 (IEA, 2019). The Peak daily demand of electricity and daily total energy is 2566.03 MW and 45.62 GWh on 22 April 2021 respectively (CEB, 2018). This increased dependence on fossil fuels has also led to an increase in Sri Lanka's GHG emissions, which while amongst the lowest in the world (ranked 194th out of a total 251 countries) as well as in South Asia (1 tCO<sub>2</sub>e/capita in 2018) has been growing steadily over the past decade (from 0.6 tCO<sub>2</sub>e/capita in 2000) (ADB, 2020).



**Fig. 3** Energy generation from different sources and consumption in different sectors for India. (Source: IEA, 2020)



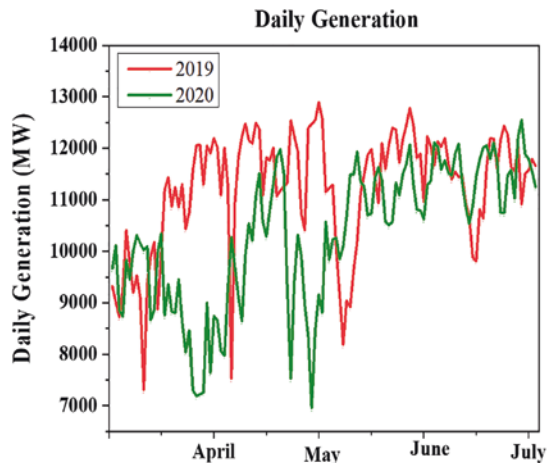
**Fig. 4** Energy generation from different sources and consumption in different sectors for Sri Lanka (Source: IEA, 2019)

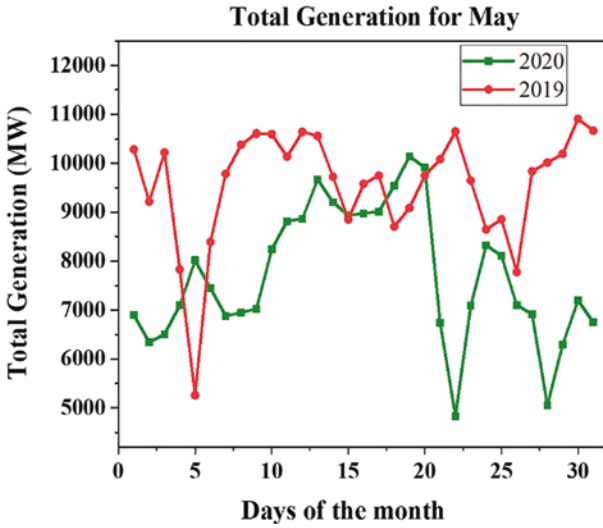
### 3 Comparison of Electricity Generation during Pre-pandemic and Pandemic Regime

Due to the severe spreading effect of COVID-19, lockdown was declared on March 17, 2020, in Bangladesh (Shammi et al., 2020, 6148). Offices, educational institutes, industries, and shopping malls were shut down during the lockdown. This lockdown also made an impact on the power generation in Bangladesh. According to the announcement of the Government of the People's Republic of Bangladesh, the lockdown was relaxed on May 31, 2020. To realize the effect of COVID-19 lockdown on power generation and the environment, electricity data of April'19—July 2019 (pre-pandemic regime) and April'20–July'20 (pandemic regime) were collected from (PGCB, 2020) and compared.

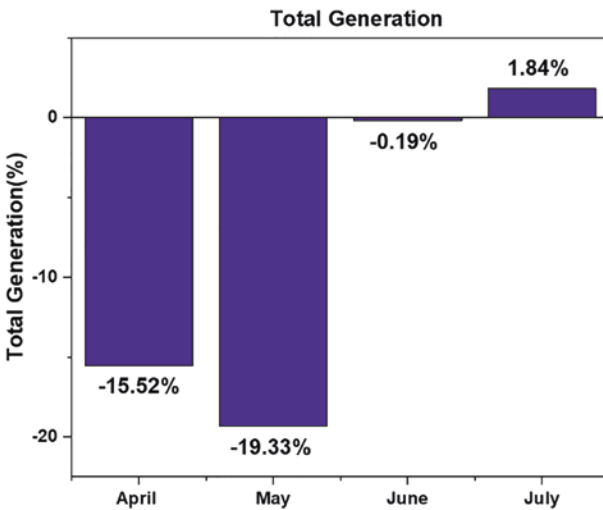
The electricity generation sagged significantly during the lockdown period (17 March 2020–31 May 2020) compared to the same period of 2019. During June 2020—July 2020 (after lockdown is relaxed), the electric power generation was quite indistinguishable from that of the same period in 2019, shown in Fig. 5 which indicates the power sector recovered the accustomed trend of generation as the lockdown was completely relaxed. From the data analysis, it is observed that power generation decreased by 15.52% and 19.33% in April and May 2020 respectively. The most prominent effect of lockdown on the power sector is realized after comparing the power generation of May 2019 with May 2020, which is shown in Fig. 6. Fig. 7 is a comparative representation of the variation of total

**Fig. 5** Daily load generation in the months of April to July in the years 2019 and 2020 in Bangladesh. (Source: Hasan et al., 2021)





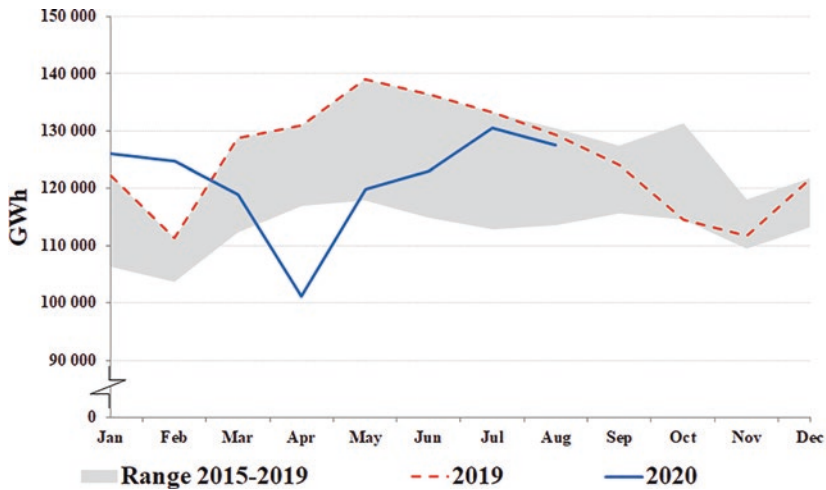
**Fig. 6** Comparative analysis of total monthly electricity generation. (Source: Hasan et al., 2021)



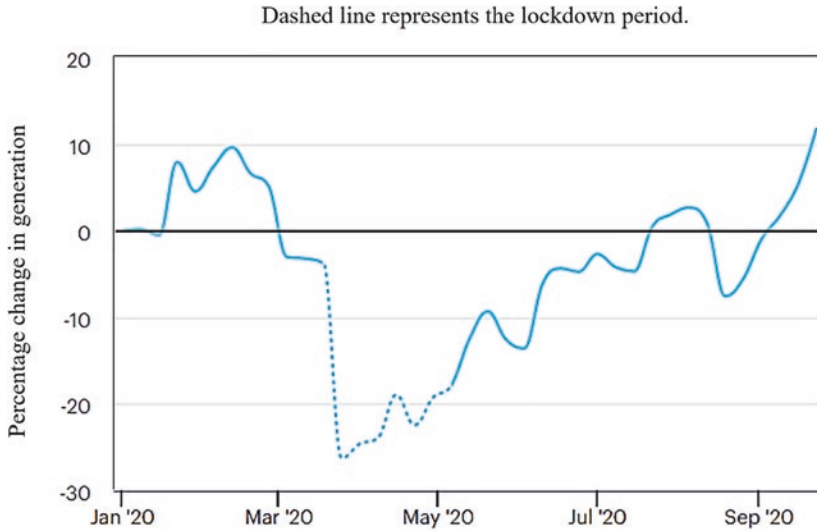
**Fig. 7** Comparison of total power generation in the months of April to July in the years 2019 and 2020 in Bangladesh. (Source: Hasan et al., 2021)

power generation (%) in Bangladesh considering the pre-pandemic and pandemic period (Hasan et al., 2021)

India is one of the most highly populated countries in the world with a population of around 1.3 billion. The power sector of India went through rapid structural changes in the last couple of decades. The power network of India is divided into five different regions: Northern Region (NR), Western Region (WR), Southern Region (SR), Eastern Region (ER) and North Eastern Region (NER). India's Power System Operation Corporation (POSOCO, 2019) oversees the national power grid. India has one of the most extensive synchronous interconnected grids in the world with an installed capacity of about 370 GW and regular base load power demand is around 150 GW. Industrial and agricultural consumption is around 50% and 25% respectively, while commercial consumption is around 8%. Likewise, in other countries, the COVID-19 outbreak started in India too and the government started acting from the middle of March 2020. In India, Janata Curfew was imposed on 22 March 2020, whereas nationwide lockdown started from 25 March 2020 and continued till 17 May 2020. Before the start of Janata Curfew, the electricity consumption across the country attained a greater magnitude around 3500 GWh. Subsequently, during the declaration, i. e., on 22 March 2020, demand started to decay and obtained a value of about 3000 GWh, continued its trend, and stretched lower most demand scale nearly 2500 GWh on 1 April 2020.



**Fig. 8** Comparative Analysis of Electricity Generation in India. (Source: IEA, 2020)

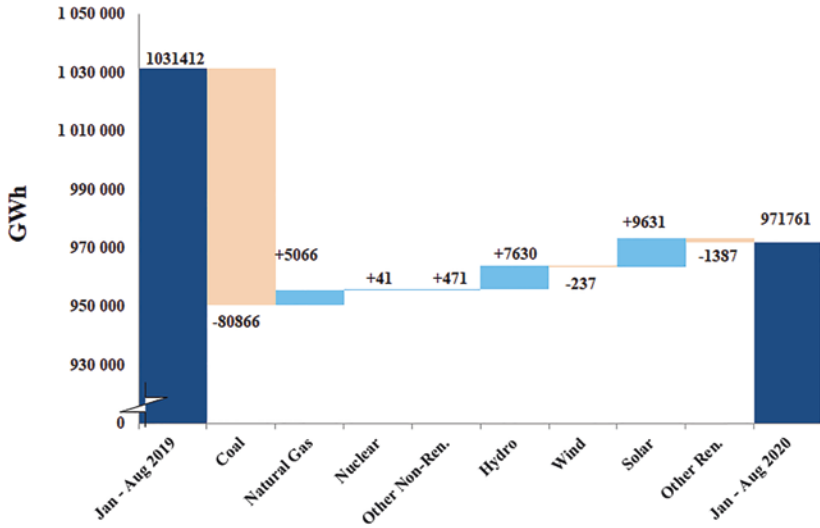


**Fig. 9** Percentage of Electricity Generation reduction due to COVID-19 lockdown in India. (Source: IEA, 2020)

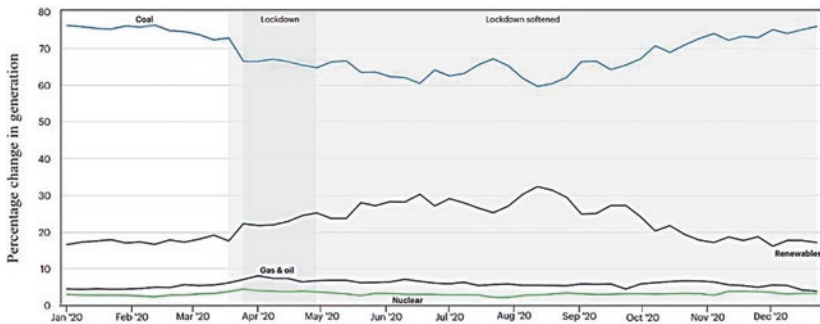
In May 2020, the average all India daily energy consumption reduced by around 1000 GWh compared to that of 2019. In August 2020, India had a total net production of 127442 GWh which is 1.4% less than August 2019. Comparative Analysis of Electricity Generation in India is shown in Fig. 8. Fig. 9 shows the percentage reduction of electricity generation during the COVID-19 lockdown period. Electricity generation for India was reduced to about 10% in March 2020 (Kandari & Kumar, 2021). During April 2020, the electricity generation in India decreased the most (26%) (IEA, 2020).

Figure 10 shows the electricity generation variation in 2019 and 2020 from January to August. During January–August 2019, the electricity generation in India was 1031412 GWh and during the same period in 2020, the electricity generation was 971761 (a reduction of 5.78%). The reason for this electricity generation reduction is the COVID-19 lockdown during the period of 25 March—17 May 2020. Fig. 11 shows that during the lockdown period in 2020, the electricity demand was less and as a result, that the most dominant electricity generating source, coal-based energy production was on the decline in India. Gas, oil and nuclear do not show any significant changes over the year. Nowadays, India is focusing on energy generation from renewable sources, which is evident from Fig. 11.



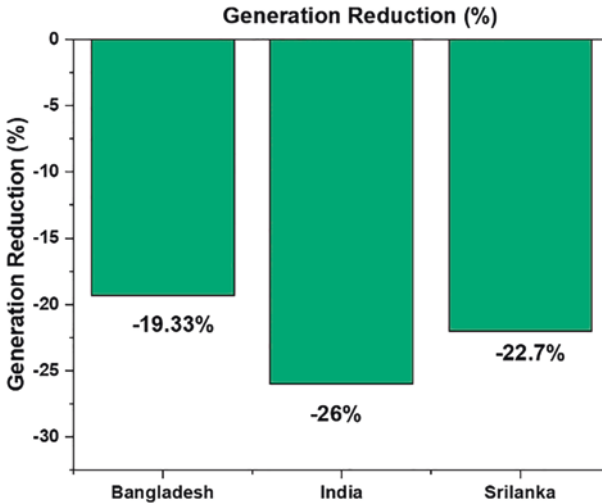


**Fig. 10** Comparative analysis of electricity generation from January-August in the years of 2019 and 2020 in India. (Source: IEA, 2020)



**Fig. 11** Effect of COVID-19 lockdown on electricity generation from different energy sources in 2020, India. (Source: IEA, 2020)

Sri Lanka reported the first case of COVID-19 on 27 January 2020. Consequently, on 20 March 2020, curfew was declared nationwide till 24 March 2020, and it was further extended till 19 April 2020. On 19 April 2020, the Govern-



**Fig. 12** Percentage electricity generation reduction due to COVID-19 in Bangladesh, India, and Sri Lanka. (Source: IEA, 2020; USAID & SARI/EI, 2020)

ment of Sri Lanka decided to partially relax the curfew by permitting inter-district travel only for essential and emergency purposes. After 52 days of curfew declaration, on 11 May 2020, the government completely relaxed the curfew by partially opening offices, industries, and businesses (Erandi et al., 2020, 1). In Sri Lanka, the average daily energy generation is 48.5 GWh and during the curfew, the daily generation reduced to 32.7 GWh. The peak demand decreased to 2000 MW from 2600 MW. During the COVID-19 lockdown, the coal-based 900 MW power plant was maintained properly which supplied 30% of the loads. The total generation was decreased in April 2020 in comparison to the same period in 2019 (USAID & SARI/EI, 2020). In Bangladesh, electricity generation was lowest in May 2020 whereas, in India and Sri Lanka, electricity generation was lowest in April 2020. Fig. 12 shows the comparative percentage of electricity generation reduction due to COVID-19 lockdown. India is highly affected by COVID-19 in the South Asian region and the electricity generation of India reduced the most in April 2020 in comparison to the other two South Asian countries considered in this paper.

## 4 COVID-19 Impacts on the Environment: GHG Emission

The demand and consequently the generation of electricity have been affected during the lockdown period due to COVID-19 pandemic. In Bangladesh and India, the maximum reductions in electricity generation have been observed in May and April respectively. In this section, the changes in greenhouse gases (GHGs) emission in the month of May for Bangladesh and in the month of April for India in the years of 2019 and 2020 are estimated and analysed. In Bangladesh, the primary energy sources in power plants are coal, natural gas, oil, hydro-power and imported high voltage direct current (HVDC) from India. In India, the primary energy sources in power plants are coal, hydro, wind, solar, and natural gas. The GHG emission due to the generated electrical energy ( $E_{generated}$ ) associated with each primary source is calculated by multiplying the emission factor (EF) of each source as follows:

$$GHG_{emission} = EF \times E_{generated} \quad (1)$$

Table 1 shows the GHG emission factors of each primary energy source presented in (Woo et al., 2017, 340) where 167 previous studies involving the life cycle assessment of GHG emission related to energy sources have been reviewed (Turconi et al., 2013, 555).

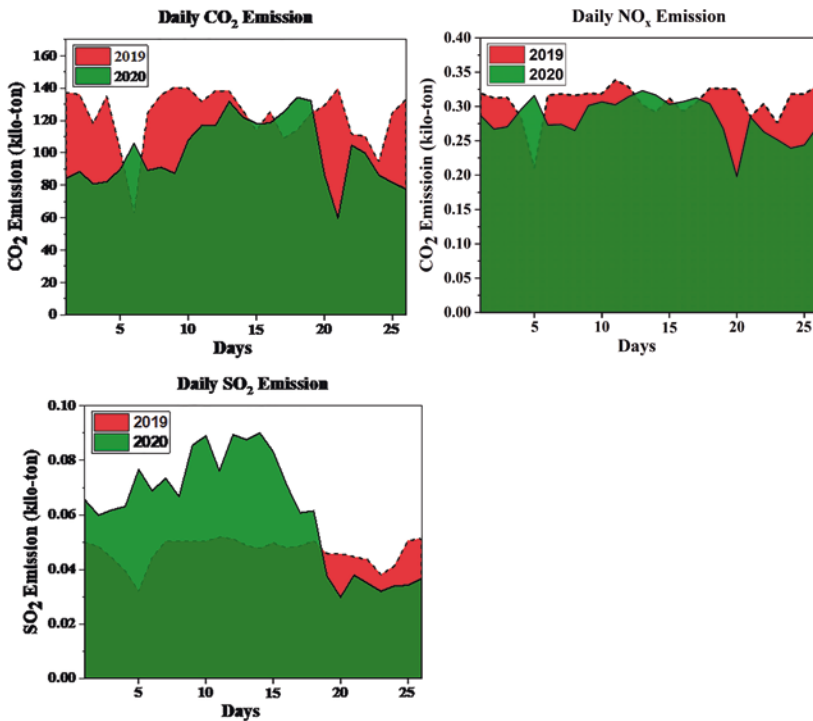
**Table 1** GHG Emission Factor for Different sources (Woo et al., 2017, 340) (Turconi et al., 2013, 555)

Energy Sources	CO <sub>2</sub> (gCO <sub>2</sub> /kWh)			NO <sub>x</sub> (gNO <sub>x</sub> /kWh)			SO <sub>2</sub> (gSO <sub>2</sub> /kWh)		
	Min	Max	Average	Min	Max	Average	Min	Max	Average
Coal	660	1370	942.33	0.3	3.9	2.1	0.03	6.7	3.365
Natural Gas	380	1000	533.17	0.2	3.8	2	0.01	0.32	0.165
Oil	530	890	773.80	0.5	1.5	1	0.85	8	4.425
Hydro-power	2	20	8.22	0.004	0.06	0.032	0.001	0.03	0.0155
Solar	13	53	65.05	0.02	0.11	0.065	0.02	0.09	0.055
Wind	3	12	17.63	0.15	0.4	0.275	0.12	0.29	0.205

### 4.1 A. Calculation of GHG emission in Bangladesh

In each case, the average values are considered to calculate the GHG emission. For Bangladesh, the GHG emission for the imported power through HVDC line from India is assumed to be zero; and in case of India, the GHG emission for other combined sources which are unspecified has been ignored.

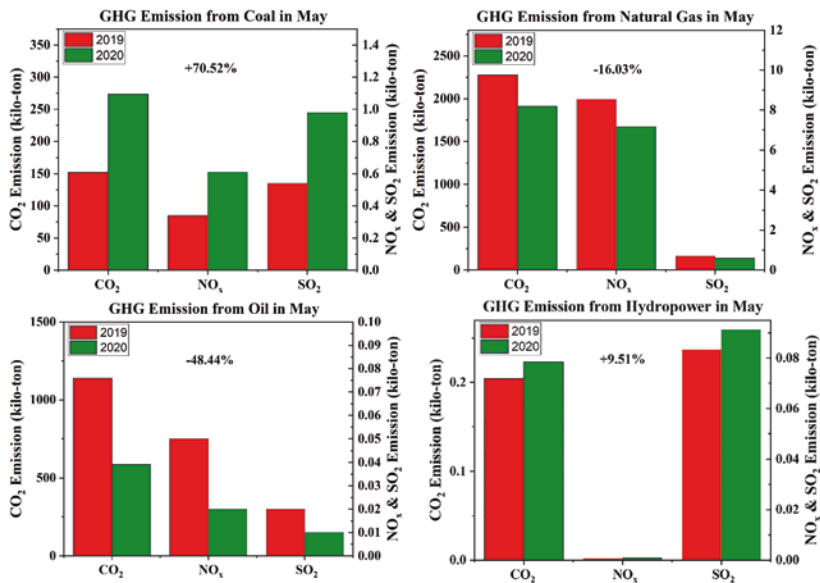
It can be seen from Fig. 13 that the daily CO<sub>2</sub> and NO<sub>x</sub> emissions in 2020 are generally lower than those of 2019 as expected. As presented in Fig. 6, the daily electricity generation reduced in the last 10 days of May due to lockdown and so did all the GHG emission. The average daily CO<sub>2</sub>, NO<sub>x</sub> and SO<sub>2</sub> emissions in May were 123.01 kiloton, 0.31 kilo- and 0.05 kiloton in 2019, and 95.59 kiloton, 0.27 kilo- and 0.06 kiloton in 2020 respectively, which clearly shows the



**Fig. 13** Daily GHG emission in the month of May in the years 2019 and 2020 in Bangladesh. (Source: Own depiction)

impact of COVID-19 pandemic on the environment due to reduced generation of electricity. The increase in the daily emission in the first couple of weeks, and consequently, the average daily  $\text{SO}_2$  emission can be contributed to increased electricity generation from coal and discussed in the next section.

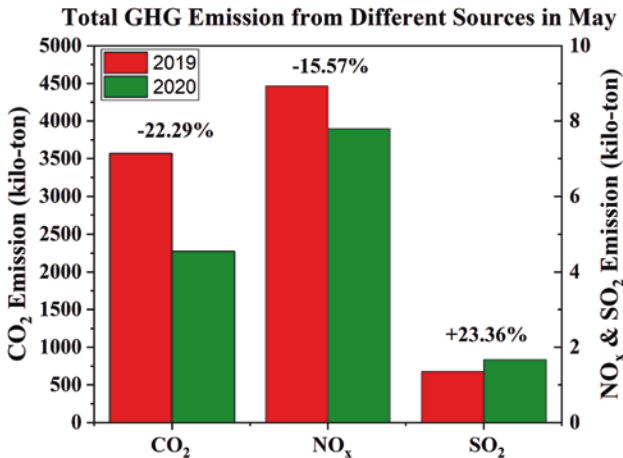
The results in Fig. 14 depict the GHG emissions due to electricity generated from different sources in Bangladesh. The GHG emissions associated with fossil fuels are substantially higher compared to the GHG emissions related to hydropower. In Bangladesh, the public power plants mainly consume natural gas and coal to generate electricity, and the private sector equally uses natural gas and oil. Thus, it can be concluded that natural gas is the primary source of electricity generation in Bangladesh. As a result, it can be observed that the highest amount of energy generated, and associated GHG emission are from natural gas, followed by oil and coal. In 2020, GHG emission from natural gas decreased by 16.03% mainly due to 19.18% (2.92 MWh to 2.36 MWh) reduced energy generated in public power plants. The electricity generation from coal increased by 79% in 2020 in comparison with that of 2019 in May (Hasan et al., 2021); and conse-



**Fig. 14** Total GHG emission from different sources in May in the years 2019 and 2020 in Bangladesh. (Source: Own depiction)

quently, GHG emissions from coal increased by 70.52%. The generated energy from oil in private sector decreased by 42.53% (1.27 MWh to 0.73 MWh) in the month May in 2020 compared to that in 2020 while the generated electricity from oil in public sector remained unchanged (Hasan et al., 2021). Therefore, the GHG emission from oil is reduced by 48.44% in 2020. Fig. 15 shows the percentage comparative GHG emission from different sources in the months of May in 2019 and 2020 in Bangladesh.

Since natural gas is the primary source of electricity generation in Bangladesh and the electricity generated from natural gas decreased by 16.03% in May 2020 compared to April 2019, the change in total GHG emission in Bangladesh is considerably influenced by it. The total CO<sub>2</sub> emission reduced by 22.29% (3567.5 kiloton to 2772.14 kiloton) and total NO<sub>x</sub> emission reduced by 15.57% (8.93 kiloton to 7.8 kiloton) in 2020 during the month of May in Bangladesh as expected. As presented in Table 1, the emission factor of SO<sub>2</sub> for coal (3.365 gSO<sub>2</sub>/kWh) is significantly higher than that of natural gas (0.165 gSO<sub>2</sub>/kWh). As a result, overall emission of SO<sub>2</sub> is greatly influenced by coal. There has been 79% increase electricity generation from coal in 2020 in compared with that of 2019 in May (Hasan et al., 2021), which led to 70.52% (0.54 kiloton to 0.98 kiloton) increase in the SO<sub>2</sub> emission from coal. Consequently, the total SO<sub>2</sub> emission increased by 23.36% (1.35 kiloton to 1.67 kiloton).



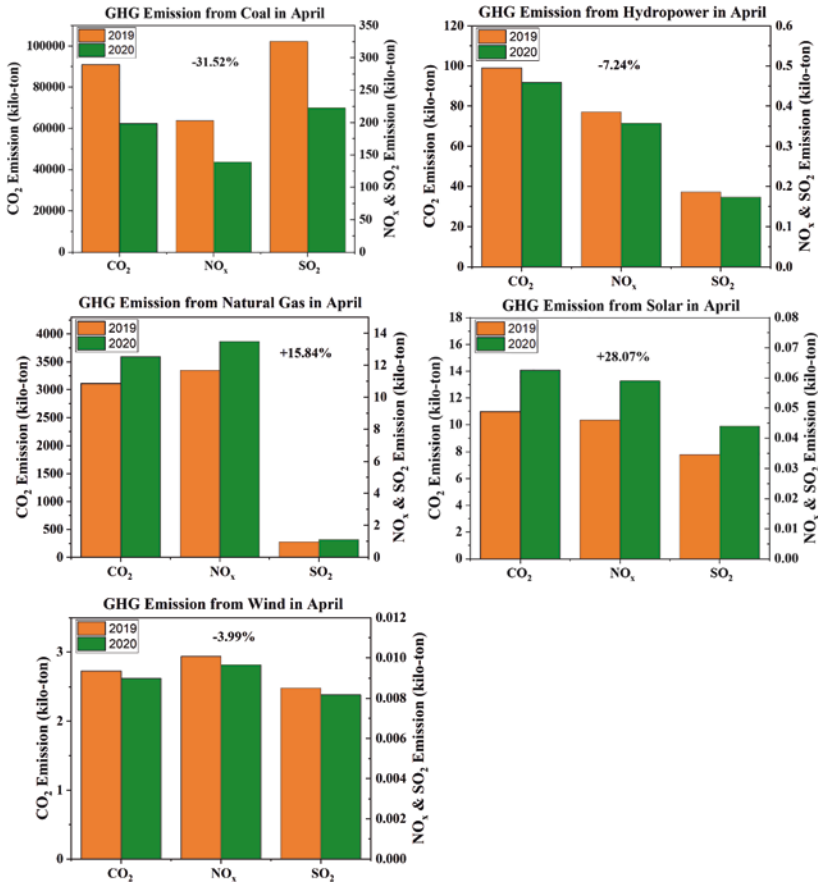
**Fig. 15** Total GHG emission in May in the years 2019 and 2020 in Bangladesh. (Source: Own depiction)

## 4.2 B. Calculation of GHG emission in India

To analyse the reduction in GHG emission associated with different sources in the month of April in India, the total GHG emission from each source are calculated and presented in Fig. 16.

The results in Fig. 16 depict the GHG emission due to electricity generated from different sources in April in the years of 2019 and 2020 in India. It can be observed that the highest amount of energy generated, and associated GHG emission are from coal, followed by natural gas and hydro. It can be noted that except natural gas and solar, the GHG emission reduced for all the sources. In April 2020, CO<sub>2</sub> emissions from coal, hydro and wind decreased by 31.52% (91066.84 kiloton to 62364.13 kiloton), 7.24% (98.96 kiloton to 91.07 kiloton) and 3.99% (2.73 kiloton to 2.62 kiloton) respectively. The increase in GHG emission from natural gas can be contributed to increase in generation of electricity from natural gas in 2020, although the overall generation from all sources combined has reduced. Solar and wind power plants may not emit GHG during the generation of electricity, but their lifetime emissions, related to the emission footprint from the manufacturing of solar cells, solar panels, and wind turbines should be considered (Sara, n. d.) (Ziegler et al., 2018, 1261). In both cases, a system lifetime of 25 years has been assumed to calculate the GHG emission. The increase of 28.07% GHG emission from solar energy suggests that new solar-based power plants have been installed in the year of 2020 in India (ET Energy World, 2020) (Renewable Energy World, 2020). Fig. 17 shows the total GHG emissions in the months of April in 2019 and 2020 in India. Since coal is the primary source of electricity generation in India, and the electricity generated from coal decreased by 31.52% (96640.1 GWh to 66180.8 GWh) in April 2020 compared to April 2019, the change in total GHG emission is greatly affected by it. As a result, the total CO<sub>2</sub> emission reduced by 29.75% (3567.5 kiloton to 2772.14 kiloton), total NO<sub>x</sub> emission reduced by 29.59% (8.93 kiloton to 7.8 kiloton), and total SO<sub>2</sub> emission reduced by 31.19% (1.35 kiloton to 1.67 kiloton).

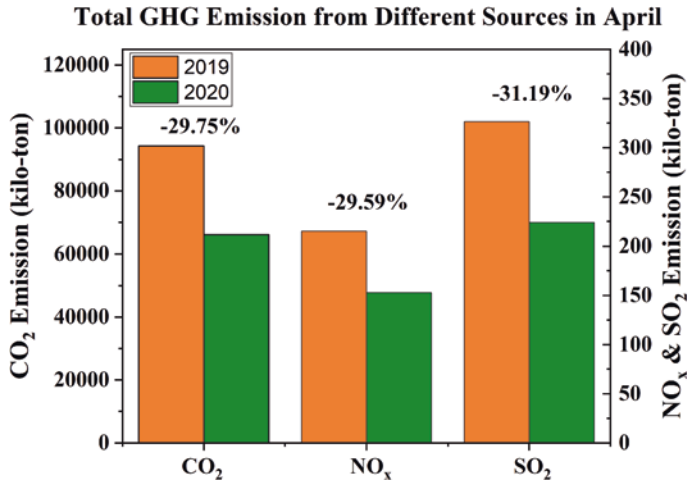
Sri Lanka produced 20.6 Mt of CO<sub>2</sub> in the year 2018 where electricity produces 8 Mt of CO<sub>2</sub> (38.84%). In 2019, 1.16 tCO<sub>2</sub> per capita CO<sub>2</sub> emission and 24.84 million-ton annual CO<sub>2</sub> emission was recorded from power sector (Ritchie & Roser, 2020). Sri Lanka experienced 10.04% SO<sub>2</sub> reduction during COVID-19 lockdown compared to the same period in 2019 (Roy et al., 2021, 144009). In India, carbon emission from the sector wise perspective, a total 2307.78 Mt of CO<sub>2</sub> was produced, and a majority of 1183 Mt of CO<sub>2</sub> (51.28%) was produced from electricity and heat producers in 2018. According to IEA, global Carbon



**Fig. 16** Total GHG emission from different sources in April in the years 2019 and 2020 in India. (Source: Own depiction)

dioxide emission reduced by 8% in 2020 compared to 2019 (IEA, 2020). Power industry contributes 29.1% of the total carbon-dioxide emission in Sri Lanka (Worldometers, 2019). For Sri Lanka, Carbon dioxide emission from electricity is 0.71 kg/KWh (ODSM, 2021). Electricity and heat play a significant role in CO<sub>2</sub> emission in all the three countries mentioned in this paper. In India, 2616 MtCO<sub>2</sub> was released in 2019 (AWI, 2020). Comparative percentage reduction of GHG





**Fig. 17** Total GHG emission in the month of April in the years 2019 and 2020 in India. (Source: Own depiction)

emission in India during lockdown shows that the reduction of CO<sub>2</sub> (-29.75%), NO<sub>x</sub> (-29.59%) and SO<sub>2</sub> (-31.19%) emission is maximum in India during April 2020 which is in line with the electricity generation reduction scenario due to COVID-19 lockdown.

## 5 Conclusion

In this paper, the impacts of the COVID-19 pandemic on the power generation of three South Asian countries (Bangladesh, India, and Sri Lanka) and the consequences on the environment due to GHG emission are presented. At first, necessary statistics related to electricity generation in Bangladesh, India, and Sri Lanka for a particular period in the year of 2019 and 2020 (during lockdown period) are collected to realize the impact of this pandemic on the power sector and environment. After that, rigorous comparative analyses are conducted. It is evident from the analysis that during the COVID-19 lockdown period, there was a 16.96% reduction of power generation in the month of May 2020 compared with that of May 2019 in Bangladesh. In India, the reduction of electricity generation was 26% in April 2020 compared to that of April 2019. Sri Lanka had a 22.7%

reduction of electricity generation in April 2020 compared to the same period in 2019. There was a significant CO<sub>2</sub> emission reduction (22.29%) in Bangladesh, in May 2020 whereas, in India, CO<sub>2</sub> reduction was 29.75% in April 2020. NO<sub>x</sub> and SO<sub>2</sub> reduction in India were 29.59% and 31.19% respectively. In Bangladesh during the lockdown in May 2020, NO<sub>x</sub> decreased by 15.57% and SO<sub>2</sub> increased by 23.36%. It is also found that the electricity generation and GHG emission reduction during lockdown agree of the severity of COVID-19 in these three countries. India is the most affected country by COVID-19 in South Asia and the power generation and GHG emission reduced the most in the case of India among the three countries discussed in this paper. In the future, a similar study can be performed for the other countries to investigate the impacts of COVID19 on the power system and GHG emission.

---

## References

- Abu-Rayash, A., & Dincer, I. (2020). "Analysis of the electricity demand trends amidst the COVID-19 coronavirus pandemic." *Energy Research & Social Science*, 68, 101682. <https://doi.org/10.1016/j.erss.2020.101682>.
- ADB—Asian Development Bank. (2020). "100% Percent Electricity Generation through Renewable Energy by 2050: Assessment of Sri Lanka's Power Sector." Asian Development Bank. July 22, 2020. <https://www.adb.org/publications/electricity-generation-renewable-energy-2050-sri-lanka>. Accessed: 30. Apr. 2021.
- AWI. (2020). "Global Carbon Budget 2020." <https://epic.awi.de/id/eprint/53493/1/Friedlingstein2020.pdf>. Accessed: 30. Apr. 2021.
- BPDB. (2020). "Bangladesh Power Development Board." [https://bpdb.gov.bd/bpdb\\_new/index.php/site/annual\\_reports](https://bpdb.gov.bd/bpdb_new/index.php/site/annual_reports). Accessed: 30. Apr. 2021.
- Carbon Brief. (19. February 2020). "Analysis: India's CO<sub>2</sub> Emissions Growth Poised to Slow Sharply in 2019." <https://www.carbonbrief.org/analysis-indias-co2-emissions-growth-poised-to-slow-sharply-in-2019>.
- CEA. (2019). "Central Electricity Authority—CEA Annual Report 2018–2019." <https://cea.nic.in/>. Accessed: 30. Apr. 2021.
- CEB. (2018). "Ceylon Electricity Board (CEB), Annual Report 2018, Government of Sri Lanka." <https://ceb.lk/electricity-generated/en>. Accessed: 30. Apr. 2021.
- Energy Statistics. (2019). "Energy Statistics 2019: Ministry of Statistics and Program Implementation: Government of India." Ministry of Statistics and Program Implementation | Government of India. <http://mospi.nic.in/publication/energy-statistics-2019>. Accessed: 30. Apr. 2021.
- Erandi, K. K., Mahasinghe, A. C., Perera, S. S., & Jayasinghe, S. (2020). "Effectiveness of the strategies implemented in Sri Lanka for controlling the COVID-19 outbreak." *Journal of Applied Mathematics*, 2020, 1–10. <https://doi.org/10.1155/2020/2954519>

- ET Energy World. (25. August 2020). "India Adds 351 MW of Solar Power Generation Capacity in Q2 2020: Report." <https://energy.economictimes.indiatimes.com/news/renewable/india-adds-351-mw-of-solar-power-generation-capacity-in-q2-2020-report/77737057>. Accessed: 30. Apr. 2021.
- Gillingham, K. T., Knittel, C. R., Li, J., Ovaere, M., & Reguant, M. (2020). "The short-run and long-run effects of Covid-19 on energy and the environment." *Joule*, 4(7), 1337–1341. <https://doi.org/10.1016/j.joule.2020.06.010>
- Grottera, C., Barbier, C., Sanches-Pereira, A., Weiss, M., de Abreu, C., Uchôa, L. G., Tudeschini, J.-M., et al. (2018). "Linking electricity consumption of home appliances and standard of living: Comparison between Brazilian and French households." *Renewable and Sustainable Energy Reviews*, 94, 877–888. <https://doi.org/10.1016/j.rser.2018.06.063>
- Zhong, H., Tan, Z., He, Y., Xie, L., & Kang, C. (2020). "Implications of COVID-19 for the electricity industry: A comprehensive review." *CSEE Journal of Power and Energy Systems*. <https://doi.org/10.17775/cseejpes.2020.02500>.
- Hosseini, S. E. (2020). "An outlook on the global development of renewable and sustainable energy at the time of COVID-19." *Energy Research & Social Science*, 68, 101633. <https://doi.org/10.1016/j.erss.2020.101633>
- IEA. (1. November 2019–2020). "Countries & Regions." IEA. <https://www.iea.org/countries>. Accessed: 24. Apr. 2021.
- Kandari, R., & Kumar, A. (2021). "COVID-19 Pandemic lockdown: Effects on the air quality of South Asia." *Environmental Sustainability*. <https://doi.org/10.1007/s42398-020-00154-6>
- Le Quéré, C., Jackson, R. B., Jones, M. W., Smith, A. J., Abernethy, S., Andrew, R. M., & De Gó, A. J. et al. (2020). "Temporary reduction in daily global CO<sub>2</sub> emissions during the COVID-19 forced confinement." *Nature Climate Change*, 10(7), 647–653. <https://doi.org/10.1038/s41558-020-0797-x>.
- Mondal, M. A. H., Denich, M., & Vlek, P. L.G. (2010). "The future choice of technologies and co-benefits of CO<sub>2</sub> emission reduction in Bangladesh power sector." *Energy, Elsevier*, 35(12), 4902–4909. <https://doi.org/10.1016/j.energy.2010.08.037>.
- National Database of Renewable Energy. (2021). "Renewable Energy Installed Capacity: 724.13 MW." RE Generation Mix. <http://www.renewableenergy.gov.bd/>. Accessed: 30. Apr. 2021.
- ODSM. (2021). "Presidential Task Force on the Energy Demand Side Management." <http://www.energy.gov.lk/ODSM/Carbon-Footprint.html>. Accessed: 30. Apr. 2021.
- PGCB. (2020). "Power Generation Company Bangladesh Limited." <https://pgcb.org.bd/>. Accessed: 30. Apr. 2021.
- POSOCO. (2019). "Power System Operation Corporation." <https://posoco.in/>. Accessed: 30. Apr. 2021.
- Renewable Energy World. (20. November 2020). "India Added 438 MW of Solar Capacity in Q32020." <https://www.renewableenergyworld.com/solar/report-india-added-438-mw-of-solar-capacity-in-q32020/#gref>. Accessed: 30. Apr. 2021.
- Ritchie, H., & Roser, M. (11. June 2020). "Sri Lanka: CO<sub>2</sub> country profile." *Our World in Data*. <https://ourworldindata.org/co2/country/sri-lanka>. Accessed: 30. Apr. 2021.
- Roy, S., Saha, M., Dhar, B., Pandit, S., & Nasrin, R. (2021). "Geospatial analysis of COVID-19 lockdown effects on air quality in the South and Southeast Asian region."

- Science of the Total Environment*, 756, 144009. <https://doi.org/10.1016/j.scitotenv.2020.144009>
- Hasan, S., Rasheduzzaman, M., & Hossain, M. M. (2021). "Impacts of COVID-19 on the environment and power sector of Bangladesh." *2021 3rd International Youth Conference on Radio Electronics, Electrical and Power Engineering (REEPE)*. <https://doi.org/10.1109/reepe51337.2021>.
- Shammi, M., Bodrud-Doza, M., Islam, A. R., & Rahman, M. M. (2020). "Strategic assessment of COVID-19 pandemic in Bangladesh: Comparative lockdown scenario analysis, public perception, and management for sustainability." *Environment, Development and Sustainability*, 23(4), 6148–6191. <https://doi.org/10.1007/s10668-020-00867-y>.
- Turconi, R., Boldrin, A., & Astrup, T. (2013). "Life cycle assessment (LCA) of electricity generation technologies: Overview, comparability and limitations." *Renewable and Sustainable Energy Reviews*, 28, 555–565. <https://doi.org/10.1016/j.rser.2013.08.013>
- USAID & SARI/EI. (25. November 2020). "Brief of proceedings of webinar on tackling the Covid-19 crisis—experience sharing by South Asian power distribution companies." *USAID and South Asia Regional Initiative for Energy Integration (SARI/EI)*. <https://sari-energy.org/wp-content/uploads/2020/11/ProceedingsWebinar-onimpact-of-COVID-19-on-SA-power-Discoms.pdf>. Accessed: 30. Apr. 2021.
- Woo, J., Choi, H., & Ahn, J. (2017). "Well-to-wheel analysis of greenhouse gas emissions for electric vehicles based on electricity generation mix: A global perspective." *Transportation Research Part D: Transport and Environment*, 51, 340–350. <https://doi.org/10.1016/j.trd.2017.01.005>.
- World Bank database. (2021). "World Development Indicators: India." <http://data.worldbank.org/country/india>. Accessed: 30. Apr. 2021.
- World Bank Group. (2018). "Options for a carbon tax in Bangladesh," <https://doi.org/10.1596/30408>.
- Worldometers. (2019). "Sri Lanka CO<sub>2</sub> emissions." <https://www.worldometers.info/co2-emissions/srilanka-co2-emissions/>. Accessed: 30. Apr. 2021.
- Yoo, S.-H., & Lee, J.-S. (2010). "Electricity consumption and economic growth: A cross-country analysis." *Energy Policy*, 38(1), 622–625. <https://doi.org/10.1016/j.enpol.2009.05.076>
- Ziegler, L., Gonzalez, E., Rubert, T., Smolka, U., & Melero, J. J. (2018). "Lifetime extension of onshore wind turbines: A review covering Germany, Spain, Denmark, and the UK." *Renewable and Sustainable Energy Reviews*, 82, 1261–1271. <https://doi.org/10.1016/j.rser.2017.09.100>

**Open Access** This chapter is licensed under the terms of the Creative Commons Attribution 4.0 International License (<http://creativecommons.org/licenses/by/4.0/>), which permits use, sharing, adaptation, distribution and reproduction in any medium or format, as long as you give appropriate credit to the original author(s) and the source, provide a link to the Creative Commons license and indicate if changes were made.

The images or other third party material in this chapter are included in the chapter's Creative Commons license, unless indicated otherwise in a credit line to the material. If material is not included in the chapter's Creative Commons license and your intended use is not permitted by statutory regulation or exceeds the permitted use, you will need to obtain permission directly from the copyright holder.





# Integrating Wind and Solar in the Indian Power System

## An Assessment with a Unit Commitment and Dispatch Model

Neshwin Rodrigues, Raghav Pachouri, Shubham Thakare, G. Renjith and Thomas Spencer

### Abstract

India's coal contribution to the total electricity generation mix stood at 73% in 2018. To meet India's NDC ambitions, the federal government announced determined targets to integrate 450 GW Renewable Energy in the grid by 2030. This paper explores the pathways to integrate high RE generation by 2030 with

---

N. Rodrigues (✉) · R. Pachouri · S. Thakare  
The Energy and Resources Institute (TERI), New Delhi, India  
e-mail: [n.rodrigues@teri.res.in](mailto:n.rodrigues@teri.res.in)

N. Rodrigues  
School of Public Policy, Indian Institute of Technology (IIT), New Delhi, India

R. Pachouri  
e-mail: [shubham.thakare@teri.res.in](mailto:shubham.thakare@teri.res.in)

S. Thakare  
e-mail: [raghav.pachouri@teri.res.in](mailto:raghav.pachouri@teri.res.in)

G. Renjith  
The Energy and Resources Institute (TERI), Kerala, India  
e-mail: [g.renjith@teri.res.in](mailto:g.renjith@teri.res.in)

T. Spencer  
International Energy Agency (IEA), Paris, France  
e-mail: [spencer.thomas885@gmail.com](mailto:spencer.thomas885@gmail.com)

© The Author(s) 2023

S. Groh et al. (eds.), *Electricity Access, Decarbonization, and Integration of Renewables*, Energiepolitik und Klimaschutz. Energy Policy and Climate Protection, [https://doi.org/10.1007/978-3-658-38215-5\\_7](https://doi.org/10.1007/978-3-658-38215-5_7)

effective balancing of supply and demand and associated challenges of flexibility requirements. A Unit commitment and economic dispatch model, which simulates the power system operation was used. The overall share of variable renewables reaches 26% and 32% in the Baseline Capacity Scenario (BCS) and High Renewable Energy Scenario (HRES) respectively. Improved ramp rates and a minimum thermal loading limit induce flexibility in the thermal fleet. In the HRES, more than 16 GW of coal plants are required for two-shift operations in April and more than 50% of days see an aggregate all-India ramp from the coal fleet in excess of 500 MW per minute. Battery Storage provides daily balancing while reducing VRE curtailment to less than 0.2% in the HRES. Nationally Coordinated dispatch shows increased power transfer from high VRE regions to export power during high VRE generation periods. It is thus found that high RE penetration is possible by 2030 at no extra system costs.

---

### Keywords

Power Systems Modelling · Unit Commitment and Economic Dispatch · Power System Flexibility · Renewable Integration System Costs · Energy Storage

---

## 1 Introduction

### 1.1 Indian Policy Context

Providing affordable and reliable electricity is essential to the achievement of India's goals of poverty eradication and economic growth. At the same time, the electricity sector is responsible for the largest share of India's energy-related CO<sub>2</sub> emissions, at 43.4% as of 2018, due to the high share of coal in the electricity mix (Enerdata, 2020). As part of its Nationally Determined Contribution (NDC) to the Paris Agreement to reduce its emission intensity per unit of GDP by 33–35% till 2030, the Government of India has set an ambitious goal of achieving 175 GW of installed capacity of renewable energy by 2022 later revising the target to 450 GW of renewable energy generation capacity by 2030 (Central Electricity Authority, 2020d). These targets are driven by the financial competitiveness of wind and solar, which have achieved auction-based tariffs substantially lower than the cost of new coal (Spencer et al., 2018).

As of October 2020, India had an installed capacity of 373 GW, excluding captive power (Central Electricity Authority, 2020b). Of this, 55% was coal and lignite, 7% gas and diesel, 12% large hydro, 10% wind, 10% solar, 2% nuclear,

and the remainder consists of small hydro and biomass (Central Electricity Authority, 2020a). Total generation from variable renewable energy (VRE), i.e. solar and wind, comprised of 9% of the total generation in fiscal year 2019–20 (Central Electricity Authority, 2020b). Thus, at one fifth of total capacity and almost 10% of total generation, wind and solar already play a significant role in the Indian power system. However, given the targets mentioned above, by 2030, the share of VRE could be expected to be above 25% of total generation (J. D. Palchak et al., 2019). Increasing the share of VRE in the electricity mix brings additional challenges of grid integration. Even at the relatively low penetration achieved today, Indian system operators are already experiencing some challenges of grid integration. These range between insufficient power evacuation capacity, regulated scheduling and dispatch within Inter-state balancing areas. In spite of having a well-developed transmission infrastructure with 432,785 circuit kilometres of transmission network (Central Electricity Authority, 2020c), curtailment issues in VRE rich states are rising due to the inadequacy of interstate transmission infrastructure (Buckley & Shah, 2019).

## 1.2 Flexibility in the Indian power system

In addition to scheduling and transmission infrastructure concerns, the integration of VRE faces challenges due to inflexible coal fired generation. India has 198 GW of coal-fired generation capacity, of which 30% are centrally owned, 33% are state-owned, and 37% are privately owned (Central Electricity Authority, 2020a). The majority of state-owned coal generators have limited ramping capabilities and a high declared technical minimum of 65–75% (Central Electricity Authority, 2019). In a recent report, the Central Electricity Authority (CEA) had emphasized the requirement for thermal power plants to facilitate VRE integration by improving ramping rates, technical minimum, and two shift operation capabilities (Central Electricity Authority, 2019). Adhering to which, these coal plants can assist in energy transition to accommodate high shares of solar and wind in the Indian grid.

Currently, however, India mostly relies on its existing hydro and gas fleets to meet its peak demand and fast ramping requirements. India has 46 GW of large hydro power capacity (Central Electricity Authority, 2020a), which consists of run of river hydro and reservoir hydro. Due to its fast ramping capability and negligible startup time, the national system operator (POSOCO) proposed that centrally-owned hydro stations provide fast response ancillary services (FRAS) through regulated up and down services in five-minute time blocks (POSOCO, 2019). India also has about 5.6 GW of pumped storage capacities under operation, and another 3.1 GW under construction (Standing Committee on Energy,



2019). However, limited utility from pumped hydro has been realized as of date. This is due to adequate spinning reserves availability from coal fleet and moderate ramp requirements. As the share of variable renewables will increase, the fast ramping requirement and intermittent generation will aid to pumped storage requirements. Gas power plants in India have provided a higher degree of ramping support to peak demand; however due to the lack of sufficient domestic gas supply and expensive imported gas, this has left a 14.3 GW gas fleet stranded in India (IEEFA, 2019).

### 1.3 Power System Modelling studies in India

In India, the Central Electricity Authority (CEA) of the Ministry of Power is the technical body responsible for power system planning. As per the 2003 Electricity Act, the omnibus legislation governing the power sector, the CEA prepares a National Electricity Plan every five years. In a recent study, the CEA studied the least cost optimal generation capacity mix required to meet the projected peak electricity demand and energy requirements for 2029–30 (Central Electricity Authority, 2020d). However, the study neglected the spatial aspect of grid integration by considering a single balancing area and neglecting other aspects of VRE integration in terms of power transfers between balancing regions, and impacts due to coal fired power plants flexibility which is a requisite for operational studies.

Energy system models such as that used by de la Rue du Can et al. (2019) are useful for assessing the sectoral and fuel interactions of different pathways, but face limitations in adequately assessing options for VRE integration and use simplified heuristics to proxy integration constraints on VRE penetration. Lawrenz et al. (2018) proposed an energy systems model that represents six sub-annual time slices to explore issues related to VRE grid integration. These studies disregard the operational aspects of power systems at hourly or sub-hourly temporal scale which is necessary to understand VRE integration, particularly in a high coal system where unit commitment constraints may be substantial.

To model high VRE integration in the power system, it is essential to incorporate operational level detail in the modelling exercise (Balachandra & Chandru, 2003), in particular at least hourly time resolution in order to explore generator cycling, start up, and minimum output levels. Deshmukh et al. (2017) used a mixed-integer unit commitment and dispatch model to model the costs of integrating high VRE in the Indian Power system by 2030, finding additional costs of 0.25–0.56 Rs/kWh for integrating more than 300 GW of VRE. Palchak et al. (2017) provides one of the most comprehensive assessments of VRE grid

integration in India using an hourly unit-commitment and dispatch model with individual representation of each Indian state and the interstate transmission system. The study assessed the achievement of the 175 GW target by 2022, and found that reducing the technical minimum of coal-based plants from 70 to 40% would result in RE curtailment to reduce from about 3.7% to 0.76% by 2022. Likewise, coordinating dispatch at national level would lead to 4% annual savings in production costs. However, this study assessed the year 2022 and a level of VRE capacity by that year which now seems unachievable. In contrast, Palchak et al. (2019) used the same modelling framework to study the impact of integrating a 22% share of VRE in total generation by 2030. However, this study looked at a limited number of scenarios.

To address these limitations, this paper presents the results of a detailed modelling exercise using a unit commitment and economic dispatch (UCED) model to assess the least production cost scenario for integrating high shares of VRE in the Indian power system by 2030. A mixed integer linear programming (MILP) formulation was used with few modifications in the source code to adjust aspects relevant to represent the Indian power system. An open source modelling framework ‘Python for Power Systems Analysis (PyPSA)’ developed by Brown et al. (2017) was used. PyPSA has been used in a growing number of studies of power system planning and VRE integration (Hörsch & Calitz, 2017; Dedecca et al., 2017; Markus & Alexandre, 2017).

The paper is structured as follows. Section 2 provides a modelling approach and scenarios description. Section 3 elucidates modelling results with recommendations and Sect. 4 concludes the paper.

---

## 2 Modelling approach

### 2.1 PyPSA-India Model Description

PyPSA is a partial equilibrium model that can optimize both short-term operation and long-term investment in the electricity system as a linear problem using linear power flow equations. Short term operation optimization computes optimal generation of all generating units to meet the time varying load for a given snapshot. Since long term investment optimization has not been considered in this paper, build-up from current year 2019 to 2030 has not been assessed endogenously to the problem formulation.

The model minimises the total annual system costs as per Eq. 1.

$$\begin{array}{l}
\min \\
g_{n,r,t}, \\
h_{n,s,t}, \\
suc_{n,r,t}, \\
LS_{n,t} \\
sdt_{n,r,t}
\end{array}
\left[ \begin{array}{l}
\sum_{n,r,t} w_t \cdot o_{n,r} \cdot g_{n,r,t} + \sum_{n,r,t} suc_{n,r,t} + \sum_{n,r,t} sdt_{n,r,t} + \sum_{n,s,t} w_t \cdot o_{n,s} \cdot \\
h_{n,s,t} + \sum_{n,r,t} w_t \cdot o_{n,ls} \cdot LS_{n,t}
\end{array} \right] \quad (1)$$

The model consists of the capacities at each bus  $n$  for generation technologies  $r$  and storage technologies  $s$ , while  $o_{n,r}$  and  $o_{n,s}$  are the variable costs of generation technologies  $r$  and storage technologies  $s$ . The start-up cost and shut-down cost for generator technologies  $r$  connected to bus  $n$  and at time  $t$  are given as  $suc_{n,r,t}$  and  $sdt_{n,r,t}$  respectively. Unserved load at time  $t$  and bus  $n$  is given by  $LS_{n,t}$  with a very high associated variable cost  $o_{n,ls}$ .

The dispatch of conventional generators  $g_{n,r,t}$  is constrained by their capacity  $G_{n,r}$  and time-dependent availabilities  $\bar{g}_{n,r,t}$  and  $\tilde{g}_{n,r,t}$ , as per Eq. 2.

$$u_{n,r,t} \cdot \tilde{g}_{n,r,t} \cdot G_{n,r} \leq g_{n,r,t} \leq u_{n,r,t} \cdot \bar{g}_{n,r,t} \cdot G_{n,r} \quad \forall n, r, t \quad (2)$$

Time-dependent availabilities  $\bar{g}_{n,r,t}$  are used to model time series resource profiles for solar and wind. The binary variable  $u_{n,r,t}$  is not applicable for generators that are not committable. For conventional generators such as coal and gas based generating units,  $\bar{g}_{n,r,t}$  and  $\tilde{g}_{n,r,t}$  are considered to be 1 and 0 respectively, while the binary variables are used to incorporate unit commitment constraints such as minimum and maximum generation levels of committable generators, as well as minimum up and down times for committable generators. The cost of generator start-ups prevent frequent generator starts and stops, while minimum up times and minimum down times constraints ensure that a given generator is on for at least a minimum number of time stamps (minimum up time) after start-up and off for at least a minimum number of time stamps (minimum down time) after shut down. These binary values help incorporate start-up and shut down costs within the objective function.

Limit on the maximum active power increase or decrease that thermal generating units are capable of from one snapshot to the next is captured by two parameters  $rd_{n,r}$  and  $ru_{n,r}$ , the ramp down limit and the ramp up limit as percentage of rated generator capacity is elucidated in Eq. 3:

$$-rd_{n,r} \cdot G_{n,r} \leq (g_{n,r,t} - g_{n,r,t-1}) \leq ru_{n,r} \cdot G_{n,r} \quad \forall n, r, t > 0 \quad (3)$$

Similarly, the dispatch of storage units  $h_{n,s,t}$  for energy storage units, connected to bus  $n$  at time  $t$  is constrained by a similar equation to that for generators in Eq. 4, where  $H_{n,s}$  is the maximum power capacity of energy storage  $s$ .

$$-H_{n,s} \leq h_{n,s,t} \leq H_{n,s} \quad \forall n, s, t \quad (4)$$

The energy levels  $e_{n,s,t}$  in Eq. 5 for energy storage  $s$  and time  $t$  has to be within limits such that:

$$\text{Min}_{\text{SOC}} \cdot E_{n,s} \leq e_{n,s,t} \leq E_{n,s} \cdot 1 \quad \forall n, s, t \quad (5)$$

where  $\text{Min}_{\text{SOC}}$  is the minimum possible state of charge of energy storage  $s$  and  $E_{n,s}$  is the energy capacity of storage  $s$ . The energy level  $e_{n,s,t}$  at time  $t$  has to be constrained consisting of the energy level in the previous time stamp  $e_{n,s,t-1}$ , dispatch of storage units during charging  $[h_{n,s,t}]^+$  and discharging  $[h_{n,s,t}]^-$  and charging and discharging efficiency ( $\eta_{n,s,+}$ ,  $\eta_{n,s,-}$ ) as indicated in Eq. 6.

$$e_{n,s,t} = e_{n,s,t-1} + \left( \text{Timestamp} * \eta_{n,s,+} * [h_{n,s,t}]^+ \right) - \left( \text{Timestamp} * \eta_{n,s,-} * [h_{n,s,t}]^- \right) \quad \forall n, s, t \quad (6)$$

Linearized power flow equations for AC networks (Ringkjøb et al., 2018) are used for the power flow constraints. This has proved useful in solving for optimal power flow (Brown et al., 2017; Hörsch et al., 2018).

The Kirchhoff formulation was used in this study to model power flow. The power balance equations are applicable for each node  $n$  and time  $t$ . This is assuming that the load is inelastic.

$$\sum_r g_{n,r,t} + \sum_s h_{n,s,t} + \sum_l \alpha_{l,n,t} \cdot f_{l,t} = d_{n,t} \quad \forall n, t \quad (7)$$

Here the electrical load at bus  $n$  at time  $t$  is  $d_{n,t}$  and the power flow on line joining to buses is  $f_{l,t}$ . The term  $\alpha_{l,n,t}$  is used to incorporate the direction of the flow i.e.  $\alpha_{l,n,t} = -1$  if line  $l$  starts at node  $n$  and  $\alpha_{l,n,t} = 1$  otherwise. The power flow on any given line is also constrained by the line rating and equivalent reactance (through the power flow constraints).

## 2.2 Technical Constraints

Table 1 provides the baseline generator constraints used in this study, which were derived drawing on the technical literature (Agora Energiewende, 2017), similar

**Table 1** Baseline generator constraints. (Source: Own depiction)

Constraint	Unit	Coal	Gas	Biomass and Waste	Hydro
Technical Minimum	% Nominal Power	55%	40%	30%	10%
Ramp rate up and down	% Nominal Power/ Hr	60%	100%	100%	100%
Minimum Up Time	Hrs	4	3	3	0
Minimum Down Time	Hrs	6	4	3	0
Start-up Costs	INR/MW	14,100	6690	14,100	0

production cost modelling exercises (D. Palchak et al., 2017), and operational data of Indian power plants (Central Electricity Authority, 2019). The model works on hourly resolution and hence ramping constraints are denominated in percent of nominal capacity per hour. The scenarios assessed in this study vary from the baseline constraints given in Table 1. More detail on scenario design is given in Sect. 2.3 below.

## 2.3 Scenario Description

As noted above, PyPSA-India was used to simulate power system operation with highly detailed representation of unit commitment and economic dispatch. Without substantial adjustments to model structure, combining detailed representation of unit commitment and new investment decisions would make the model problem computationally intractable (Palmintier & Webster, 2011). For this reason, scenarios are defined exogenous to the model for 2030, drawing on the available literature as described below. The scenarios analyzed in this paper have been designed across three different parameters, namely production capacities, transmission system, and power system flexibility.

## 2.4 Production capacities

This refers to the assumptions regarding future capacities of different generation technologies, such as coal, gas, hydro, nuclear, wind, and solar. The capacity assumptions are defined exogenously from the model, based on recent studies by the Central Electricity Authority. Two contrasting scenarios are analyzed in

this study. First, the Baseline Capacities Scenario (indicated in the scenario name by the notation B) assumes a mix of coal and renewables by 2030, and reflects broadly the assumptions of the 2018 National Electricity Plan, developed by the Central Electricity Authority (2018a). In the second scenario, the High Renewable Energy Scenario (indicated in the scenario name by the notation H), has a higher level of renewable energy production capacity of 450 GW by 2030, reflecting the assumptions of the CEA's more recent capacity expansion study (Central Electricity Authority, 2020d). Table 2 depicts the scenarios. (Table 2).

### 2.4.1 Transmission system

Two contrasting transmission scenarios are developed. In the Unconstrained Transmission Scenario, the power transfer capacities of each interstate transmission line have been expanded sufficiently by 2030 such that power can flow around the country in an unconstrained manner. A corollary – but implicit – assumption here is that the electricity market ‘infrastructure’ is likewise developed by 2030 to allow seamless interstate scheduling and dispatch of power. In the Expanded Transmission Scenario, the transmission system has been expanded by 2030 in line with existing plans, such as the National Electricity Plan, such that there will still be some capacity constraints in power transfer (Central Electricity Authority, 2018b). This scenario reflects a more fragmented electricity

**Table 2** Installed capacities in the two scenarios for the year 2030. (Source: Own depiction)

Technology source	Installed Capacity (GW)	
	Baseline scenario (B)	High RE Scenario (H)
Thermal	263	263
Nuclear	17	17
Large Hydro	74	74
Wind	129	169
Solar	189	229
Biomass and waste	23	23
Small Hydro	10	10
<b>Total</b>	<b>705</b>	<b>785</b>

Note: Thermal refers to coal, lignite, imported and domestic gas, and liquid fuel plants. Large hydro refers to dispatchable pondage and reservoir hydro and run-of-river hydro above 25 MW. Wind refers to only onshore wind

**Table 3** Description of transmission scenarios. (Source: Own depiction)

Notation	Transmission Scenario	Description
E	Extended Transmission	Interstate transmission capacities extended to 2030 as per the National Electricity Plan
U	Unconstrained Transmission	Interstate transmission capacities extended such that there are no physical constraints on power transfer between states

market, where power transfer is constrained by some infrastructural bottlenecks. Table 3 describes the transmission scenarios.

### 2.4.2 Power system flexibility

This refers to the capacity of the power system to flexibly integrate VRE, through supply-side, demand-side, and storage flexibilities (transmission flexibility is dealt with previously). In particular, two aspects are studied. First, the impact of lower or higher technical minimum for coal-based power plants is assessed. State Coal fleet has currently inflexible technical minimum of 70%. In this regard a more flexible fleet is analyzed pertaining to its high contribution in coal capacity mix. Further, in a less optimistic scenario a low flexible thermal fleet is foreseen if retrofits would be undertaken slowly by 2030. This is a crucial parameter for the grid integration of VRE in India, as it allows the coal fleet to back down output when VRE is high (for example, at midday for solar) and ramp it up quickly when VRE output falls (for example, in the evening). Second, the impact of integrating battery storage in the power system by 2030 is foreseen. Table 4 provides a description of the flexibility scenarios.

### 2.4.3 Nomenclature of Scenarios

This paper follows a specific nomenclature to define various scenarios under this study. The name of the scenario consists of 4 letters. The first letter defines the capacity type, the second letter defines the transmission network system, and the remaining two letters define the power system flexibility type. For example the nomenclature HEHT indicates High Renewables, Expanded Transmission, High Thermal Flexibility scenario. After taking all the above parameters of production capacities, transmission system, and power system flexibility, seven scenarios have been prepared. Table 5 provides an overview of the seven unique scenarios analyzed in this paper. BEBF and BELT scenarios were selected to assess if a fairly expanded transmission and a moderate to limited coal flexibility

**Table 4** Description of power system flexibility scenarios. (Source: Own depiction)

Notation	Flexibility Type	Description
BF	Baseline flexibility	All coal-fired stations can achieve a technical minimum of 55%
LT	Low thermal flexibility	Centrally owned and privately owned coal-fired stations can achieve a technical minimum of 55%. State owned coal-fired stations can only achieve a technical minimum of 65%
HT	High thermal flexibility	Centrally owned and privately owned coal-fired stations can achieve a 40% technical minimum from current 55%. State owned plants can achieve a 55% technical minimum from current 70%
BS	High battery storage flexibility	All coal-fired stations can achieve a technical minimum of 55%, additional battery capacity of 120 GWh/60 GW

**Table 5** Final scenarios analysed in this paper. (Source: Own depiction)

Capacity Scenario	Transmission Scenario	Flexibility Scenario	Notation
Baseline Capacity Scenario	Expanded Transmission Scenario	Baseline Flexibility Scenario	BEBF
		Low Thermal Flexibility Scenario	BELT
	Unconstrained Transmission Scenario	Baseline Flexibility Scenario	BUBF
High Renewable Energy Scenario	Expanded Transmission Scenario	Baseline Flexibility Scenario	HEBF
		Battery Storage Flexibility Scenario	HEBS
		High Thermal Flexibility Scenario	HEHT
	Unconstrained Transmission Scenario	Baseline Flexibility Scenario	HUB

could manage the fair transition to a renewable energy trajectory by mid-term. Similarly with BUBF, an assessment with baseline flexibility and unrestricted transmission corridor was carried out to assess maximum transfer capacities between the Inter-state transmission corridors. In HRES scenario family, a



high degree of flexibility is assessed through HEBS, HEHT and HUB. This was predominantly identified to investigate the integration of battery storage with expected augmentation of transmission corridor and a high level of thermal flexibility across all thermal fleets.

### 3 Aggregate Scenario Results

#### 3.1 Results Summary

This section provides a brief overview of the key results of the scenarios analyzed (Table 6). The results include key indicators such as unserved load, wind and solar curtailment and plant load factor (PLF). Note that each of the scenarios analyzed has same energy requirement (2260 TWh) and peak load (304 GW).

Across scenarios, unserved load was nearly zero. Some of the variance in the small amounts of unserved load was driven by stochastic generator outages rather than the dynamics of the scenarios themselves. For example, the Baseline Capacities, Expanded Transmission, Low Thermal Flexibility scenario (BELT) had lower unserved load than the Baseline Capacities, Unconstrained Transmission, Baseline Flexibility (BUBF), despite having less transmission and less thermal flexibility. This also suggests that the capacities envisaged in both capacity scenarios are broadly robust to a range of power system flexibility outcomes.

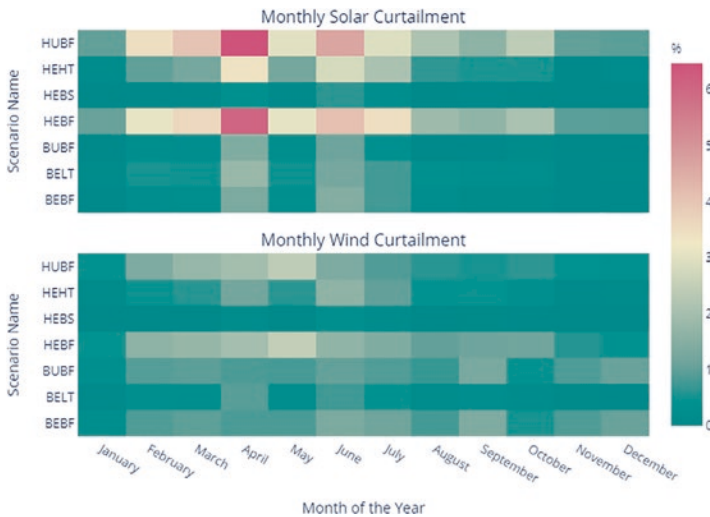
**Table 6** Key scenario results. (Source: Own depiction)

Scenario Name	Unserved Load	Solar Curtailment	Wind Curtailment	Gas PLF	Hydro PLF	Coal PLF
	MWh	%	%	%	%	%
BEBF	0.00	0.41	0.27	16.75	36.15	65.48
BELT	2.00	0.53	0.34	16.70	36.04	65.55
BUBF	38.74	0.34	0.01	16.66	36.03	65.55
HEBF	39.19	2.73	1.29	16.47	35.32	58.77
HEBS	0.00	0.10	0.08	16.55	36.05	57.77
HEHT	21.16	1.16	0.73	16.62	35.68	58.34
HUBF	214.00	3.00	0.92	16.41	35.06	58.92

### 3.2 Curtailment

Annual VRE curtailment ranges from 0.2% in the High Renewables, Expanded Transmission, Battery Storage Flexibility scenario (HEBS) to 4% in High Renewables, Expanded Transmission, Baseline Flexibility scenario (HEBF). The high curtailment in the HEBF scenario is mostly due to the operational constraints of dispatchable sources during the times of excess solar injection in mid-day and excess wind injection during monsoon. The similar curtailment issues in HRES, Transmission Flexibility and low curtailment in HRES, Storage Flexibility scenario confirms that the curtailment is largely driven by inadequate additional flexibility options rather than the transmission availability.

Figure 1 shows monthly solar and wind curtailment by scenario. Solar curtailment is more intense in the months of March, April, May, June. This is because, particularly in April, the evening peak load requirement is high and the availability of wind and hydro resources are relatively low, as it is before the start of monsoon. This leaves the daily ramping burden to coal. Given the inadequate flexibility of coal to shut down at mid-day and turn on to support evening peak, solar has to curtail to make the coal available on standby and to contribute to peak load. For wind, the curtailment concentrates in monsoon where its output is



**Fig. 1** Monthly wind and solar curtailment by scenario. (Source: Own depiction)

highest. Adding the hydro output which is high during the monsoon forces coal to shut down. As the sufficient coal capacity is required to meet the variation in net-load, the model is curtailing wind output. However, the peak monthly curtailment is low compared to solar with maximum value of 2.5%, occurring in the month of July in the High Renewable, Expanded Transmission, and Baseline Flexibility scenario. Curtailment is substantially reduced in the High Renewable, Expanded Transmission, Battery Storage Flexibility Scenario (HEBS) and the High Renewables, Expanded Transmission, High Thermal Flexibility Scenario (HEHT). This is due to the ability of storage to absorb high solar injection and contribute to evening peak (HEBS), or the lower technical minimum facilitating higher solar injection (HEHT). Curtailment is not substantially reduced in the High Renewables, Unlimited Transmission, Baseline Flexibility Scenario, indicating that it is the aggregate flexibility of the dispatchable fleet which determines curtailment, not localized transmission bottlenecks.

### **3.3 Plant Load Factor**

The coal fleet PLF varies marginally in Baseline Capacity scenarios between 68.48% and 68.55%. In High Renewable scenarios, this declines significantly to the range of 57.77% and 58.92% in Transmission Flex and Storage Flex respectively. In the last four fiscal years, the coal PLF averaged 59%, indicating that if renewables and coal capacity and demand evolve as per the Baseline Capacity scenarios in this paper, the current situation of low coal PLF will continue. The hydro PLF is relatively stable throughout all the scenarios, reflective of its zero marginal costs and high operating flexibility which helps in balancing VRE whenever required. Hydro is thus constrained by energy availability determined by the seasonal flow of India's river systems, not marginal cost. The gas PLF is consistently low at around 17% across all scenarios due to the limited availability of cheap domestic gas, and high cost of imported gas.

### **3.4 System Costs**

This section summarises the implication of scenarios in terms of total system generation cost, which is further broken down to fixed and variable costs. Here, the per unit system-wide fixed cost in the High Renewable scenarios is higher than in the Baseline Capacity scenarios as the total installed capacity is substantially higher. In the HEBF scenario, the system-wide fixed cost increases to

2.63 INR/KWh compared to the HEBF scenario with 2.37 INR/KWh. Further in the HEBS scenario, this again increases to 2.77 INR/KWh, driven by additional investments in battery storage facilities. However, High Renewable scenarios result in lower variable cost compared to Baseline Capacity scenarios due to the large share of zero marginal cost renewables in the system. In the BEBF scenario per unit variable cost is higher by 0.23 INR/KWh than in HEBF scenario. This gap further raises to 0.29 INR/KWh in HEBS scenario, as storage outcompetes high marginal cost sources of generation and reduces the need for expensive starts and stops. The total system-wide generation costs in BEBF scenario is 4.8 INR/kWh and 4.83 INR/kWh in the HEBF scenario. The total system cost is highest in the HEBS scenario at 4.92 INR/kWh. In effect, the total system-wide generation costs between two broad capacity scenarios are almost identical, and certainly within the uncertainty margin of these calculations (Fig. 2).

### 3.5 Operation of the Coal Fleet

With an increasing VRE share in the generation mix, coal fleet contribution is reducing. In base line and high RE scenarios generation share of coal power plants and annual PLFs are varying from 57% to 50% and 66% to 58%



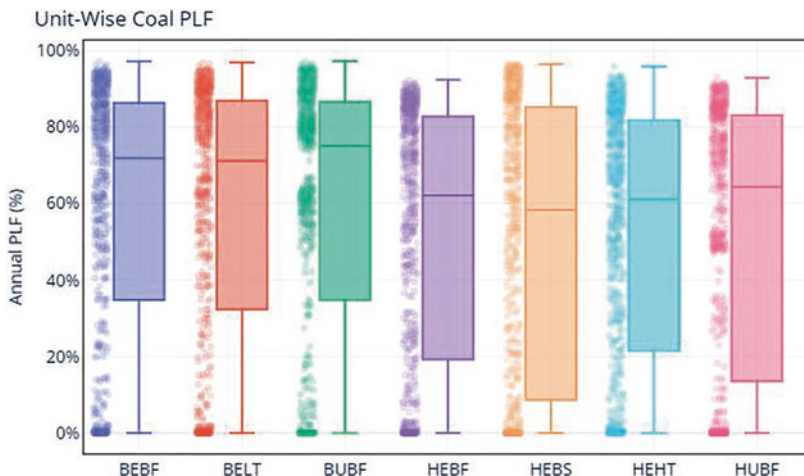
**Fig. 2** System generation costs by scenario. (Source: Own Depiction)

respectively. Impacts on plant performance due to integration of VRE will be discussed in subsequent sections in detail.

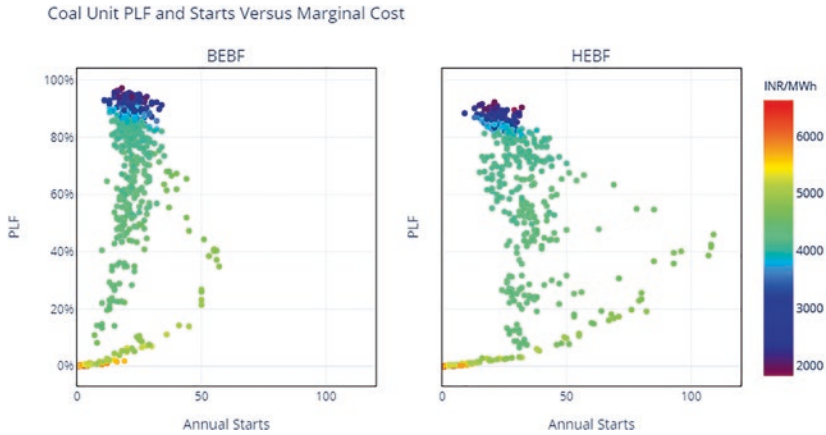
### 3.5.1 Unit-Wise PLF by Scenario

In the Baseline Capacity scenarios, the coal fleet PLF is around 66%. It increases from today's levels of 58%–60% (56% in fiscal year 2019–2020), because load grows faster than the addition of new coal-based generating resources. By contrast, in the High Renewables scenario the coal fleet PLF remains in the order of 57%–58%. Figure 3 shows the unit-wise distribution of the coal fleet PLF in scenarios analysed in this paper. An important conclusion emerging from Fig. 3 is the large variation on annual PLF across the coal fleet. On one end there are a number of plants operating at close to 85% annual PLF, notably pit head coal plants with very low variable costs, and on the other end of the extreme, there is a group of plants, which, regardless of the scenario, never start. The relationship between unit-wise PLF and marginal costs is analysed further in Fig. 4 below.

Another important conclusion relates to the impact of the different flexibility scenarios on the coal fleet PLF. From Fig. 3 it can be seen that the spread of unit PLF is higher in High Renewables scenarios, particularly in the HEBS scenario. In this scenario, the model substitutes discharge for the high marginal cost coal units that are used to meet peak demand in other scenarios. In the HEBS scenario, the median coal plant PLF is four percentage points lower than the median coal



**Fig. 3** Unit-wise coal PLF by scenario. (Source: Own Depiction)



**Fig. 4** Unit-wise PLF and starts as a function of marginal costs. (Source: Own Depiction)

plant PLF in the HEBF scenario without storage, while the PLF of the bottom quartile of plants is a full ten percentage points lower in the HEBS compared to the HEBF scenario. This result shows that there is significant scope for battery storage to compete against the higher marginal cost coal plants.

### 3.5.2 Unit-Wise Coal PLF and Unit Starts Versus Marginal Cost

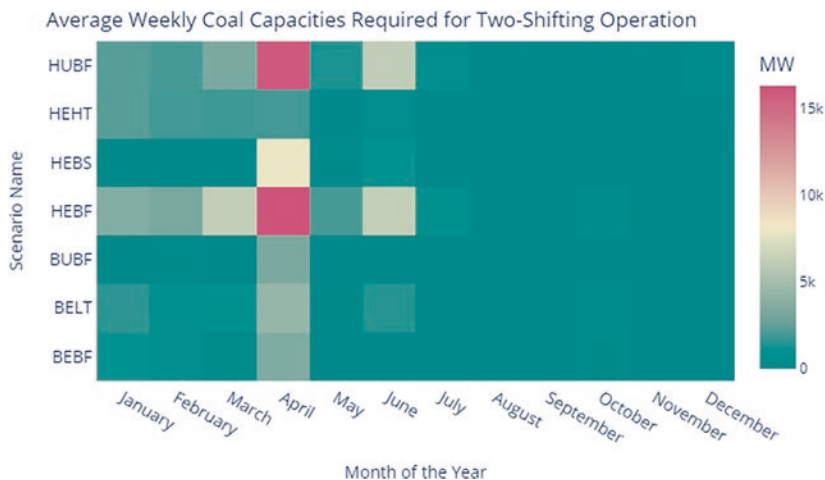
Figure 4 shows unit-wise coal PLF on the y-axis versus unit-wise annual starts on the x-axis. Marker colour represents the unit-wise marginal cost. Two scenarios are selected for representation, the BEBF and HEBF scenarios. As expected, PLF is inversely correlated with marginal cost. As the level of renewables increases between the BEBF and HEBF scenarios, unit-wise PLFs are reduced, and the number of unit-wise annual starts is increased substantially. The growth in annual starts is particularly noticeable for the plants at the right end of the distribution, with annual starts for the most aggressively cycled plants doubling between the scenarios.

### 3.5.3 Two-Shift Operation of the Coal Fleet

Two-shifting refers to coal unit operation in which the unit is switched on and off again within a short period of time, and on a regular basis. Due to operational constraints of technical minimum and minimum shut down time, at times of high evening peak demand some coal plants are required to operate in two-shifting

mode, even if some solar is curtailed and considering high start-up costs. For analysing the two-shift operation by coal stations, for the purposes of this paper two shifting is defined as four or more unit starts within a week.

Figure 5 displays a heatmap of the coal unit capacities on two-shifting operation per scenario across the months of year. According to the dispatch results, about 3–4 GW of coal capacity runs on two shifting operation throughout the year in Baseline Capacity scenarios. This capacity will increase to a maximum of 20 GW, with a range between 5–20 GW for several months of the year, in the High Renewable capacity scenarios particularly in March and April. In the HELT scenario, the higher technical minimum of state-owned plants (65%) forces more plants to operate on two-shifting in order to accommodate the injection of VRE at midday. Similarly, the improvement of thermal flexibility in the HEHT scenario decreases the requirement for two-shifting. The lower technical minimum achievable by central and IPP plants allows the coal fleet to turn down to a lower level to accommodate renewables injection at midday, without the necessity of plants operating on two-shifting.

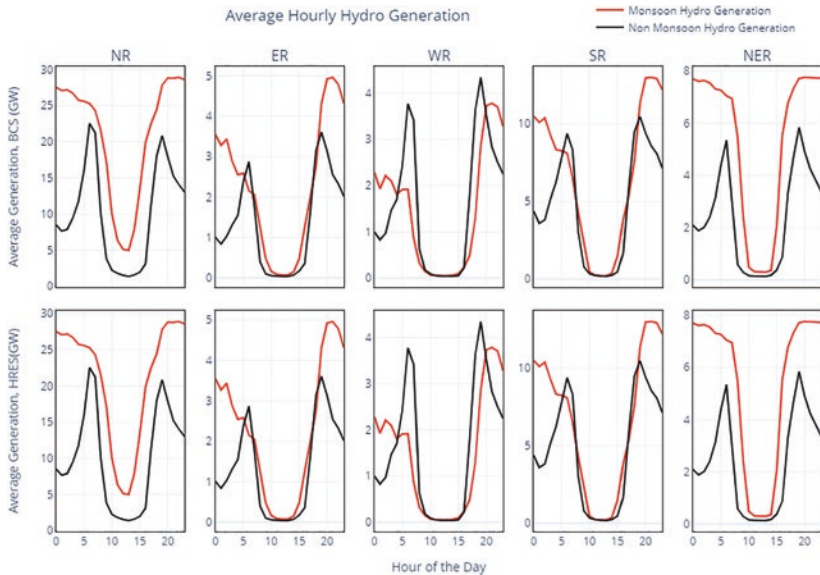


**Fig. 5** Monthly coal capacity on two-shift operation by scenario. (Source: Own Depiction)

### 3.6 Insights in the Operation of Gas and Hydro

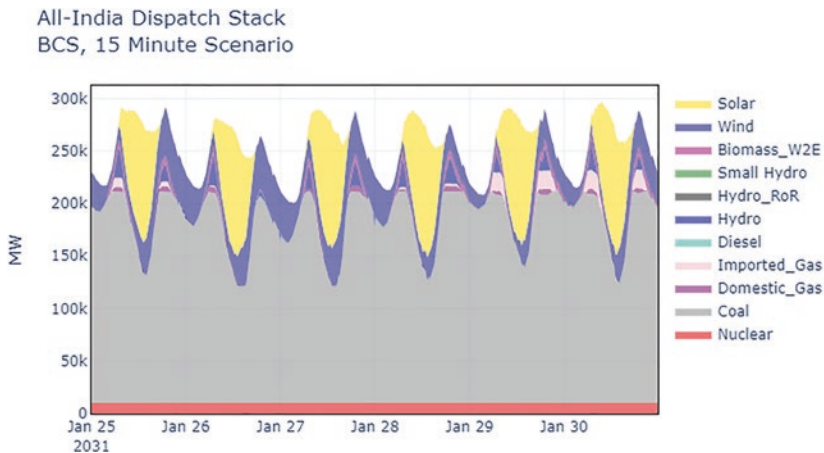
The hydro fleet offers low cost and substantial supply side flexibility by quick ramp up and down support in order to cater peak power demand requirements (in morning and evening). Considering this advantage, hydro can ramp down quickly during midday to accommodate more solar in the grid. However, the power output varies based on monsoon and non-monsoon seasons as seen in Fig. 6. Therefore, ensuring a high degree of flexibility and coordinated dispatch from India’s hydro fleet is critical to the integration of high levels of VRE.

The gas fleet also offers higher operational flexibility as compared to coal. However, the dispatch of imported gas is limited by its high marginal cost (considered delivered price of \$10-\$12/mmbtu). The results suggest that the non-competitiveness of imported gas based power with other existing options makes it an unattractive option to dispatch in an hourly resolution. However, in a sub-hourly (15 min) baseline capacity scenario, the result suggests the role of imported natural gas based fleet as a peaking power option as seen in Fig. 7 due to the stringency of ramping resources in the system.



**Fig. 6** Average hourly region-wise hydro generation. (Source: Own Depiction)



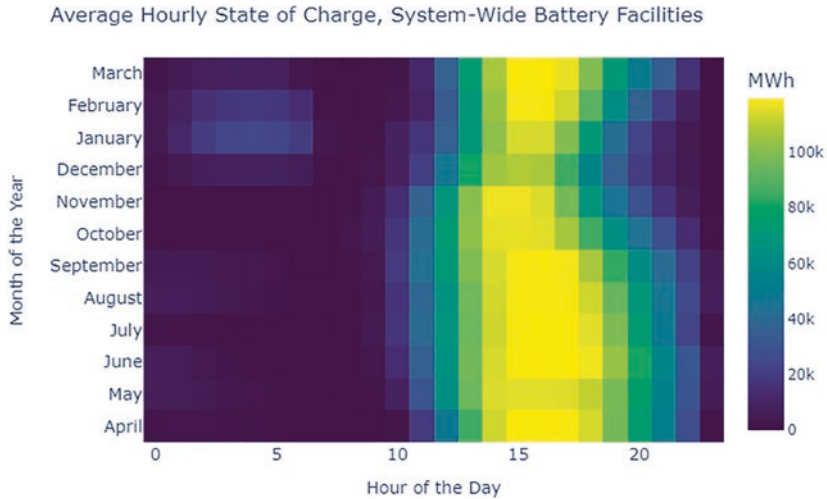


**Fig. 7** All-India dispatch stack, BCS, 15-min scenario. (Source: Own Depiction)

### 3.7 Role of Battery Storage

In the HEBS Scenario mentioned in Sect. 3, the model includes 60 GW, 120 GWh of battery storage. Here the sizing and allocation of Battery capacities is examined through state-level solar and wind curtailment in the HEBF and BEBF scenarios in form of the curtailment duration curves. Accordingly looking at steep curtailment curves, the size of battery facilities is calculated to ensure sufficient operating hours in the year and to make each battery unit a worthwhile investment. Given the steepness of the curtailment duration curves in the HEBF and BEBF scenarios, a power to energy ratio of 2 was most effective at reducing curtailment while minimizing the investment in storage.

Figure 8 below shows the average hourly state of charge (SoC) of the battery facilities in the power system, by hour of the day and month of the year. The battery facilities tend to begin the day with a zero SoC, indicating that they have discharged the previous day and have not charged in the final hours of the day. SoC tends to increase towards the midday, as the batteries assist with the integration of solar energy into the grid and reduce the need for solar curtailment, or coal plant cycling. By evening the SoC of the battery facilities reduce, as they discharge power to provide peak support and thus reduce the need for committed coal generation to be online to meet the evening peak.



**Fig. 8** Average hourly state of charge. (Source: Own Depiction)

## 4 Conclusion

The aforementioned analysis based on the unit commitment and economic dispatch model indicates a clear pathway to attain a moderate to high level of renewable energy grid integration in India by 2030. This pathway is subject to a robust policy and regulatory interventions at national and sub-national level. It envisages a massive change in supply and demand side interventions to impart operational flexibility and demand shift to manage the peak demand.

*Power System Flexibility:* The Analysis suggests that substantial flexibility will come from the coal fleet. The BCS, Low Thermal Flexibility scenario showed a substantial increase in the risks of curtailment with decreasing thermal plant flexibility. Increasing the transparency around state-level scheduling and dispatch, and plant performance, can increase the understanding of how the burden of supply-side flexibility is being shared among different players in the system. The degree of flexibility required from the coal fleet is potentially challenging to meet, and perhaps the real advantage of battery storage in the next few years will be in reducing the operational stress on the power system. The analysis presented here suggests that an aggregate energy capacity of about 120 GWh, with a relatively low power to energy ratio of 2, would have benefits in terms of reducing

curtailment and the aggressive cycling required of the coal system. The analysis also suggests that the requirement for storage would really begin to value more in HRES. In the BCS, curtailment and metrics such as maximum hourly ramp rate or capacity required for two-shifting appear more manageable. This suggests that the development of battery capacities should be seen as a mid-term investment, preparing the power system for greater shares of VRE thereafter.

*Policy for Planning:* The electricity sector is driven by the requirement to balance supply and demand. The sector encompasses a very long value chain, from generation, transmission, distribution, and consumption, along which different players respond to different incentives and physical constraints. The analysis shows that the median trade intensity (the sum of imports and exports over the sum of imports, exports, and load) among Indian states is almost 50%, implying a high level of interstate power transfer and coordinated scheduling and dispatch. Thus, Planning should be seen as a mechanism for coordinating the expectations of players across the whole value chain.

Future work in the context could be focused towards a more robust power system modelling with scenarios detailing uncertainties due to COVID shocks and changing demand. An ever changing economic growth and disruptive technologies have changed the way of generating electricity to end consumption. Hence, future models need to be elaborate on limitations of deterministic approaches towards power system planning. Although an operations model can detail the level on RE integration, the actual essence of future power system planning can be enhanced by integrated capacity expansion and unit commitment models working in tandem.

---

## References

- Agora Energiewende. (2017). *Flexibility in thermal power plants – with a focus on existing coal-fired power plants*.
- Balachandra, P., & Chandru, V. (2003). Supply demand matching in resource constrained electricity systems. *Energy Conversion and Management*, 44(3), 411–437. [https://doi.org/10.1016/S0196-8904\(02\)00058-4](https://doi.org/10.1016/S0196-8904(02)00058-4)
- Bhattacharyya, S. C. (2015). Influence of India's transformation on residential energy demand. *Applied Energy*, 143, 228–237. <https://doi.org/10.1016/j.apenergy.2015.01.048>
- Brown, T., Jonas, H., & David, S. (2017). "PyPSA: python for power system analysis." *Journal of Open Research Software*, 6(1), p.4. <https://doi.org/10.5334/jors.188>.
- Buckley, T., & Shah, K. (2019). *India's grid transmission infrastructure needs further modernisation, urgently*.
- Central Electricity Authority. (2018a). "National Electricity Plan (Vol. 1) Generation."
- Central Electricity Authority. (2018b). "National Electricity Plan (Vol. II) Transmission."

- Central Electricity Authority. (2019). "Flexible operation of thermal power plant for integration of renewable generation," no. January: 160. [http://www.cea.nic.in/reports/other/thermal/trm/flexible\\_operation.pdf](http://www.cea.nic.in/reports/other/thermal/trm/flexible_operation.pdf).
- Central Electricity Authority. (2020a). "All India installed capacity (in MW) of power stations (As on 30.09.2020a)."
- Central Electricity Authority. (2020b). "CEA-installed capacity." 2020b. <http://www.cea.nic.in/monthlyinstalledcapacity.html>.
- Central Electricity Authority. 2020c. "Progress of Transmission Sector in the Country up to Sep-20." New Delhi.
- Central Electricity Authority. (2020d). "Report on optimal generation capacity mix for 2029–30."
- Dedecca, J. G., Hakvoort, R. A., & Herder, P. M. (2017). "Transmission expansion simulation for the European northern seas offshore grid." *Energy*, 125, 805–24. <https://doi.org/10.1016/j.energy.2017.02.111>.
- Deshmukh, R., Duncan C., Nikit A., & Amol P. (2017). "Cost and value of wind and solar in India's electric system in 2030."
- Enerdata. (2020). "Global energy and CO<sub>2</sub> data." 2020.
- Hörsch, J. & Calitz, J. (2017). "PyPSA-ZA: investment and operation co-optimization of integrating wind and Solar in South Africa at high spatial and temporal detail". <http://arxiv.org/abs/1710.11199>.
- Hörsch, J., Hofmann, F., Schlachtberger, D., & Brown, T. (2018). PyPSA-Eur: An open optimisation model of the European transmission system. *Energy Strategy Reviews*, 22, 207–215. <https://doi.org/10.1016/j.esr.2018.08.012>
- IEEFA. (2019). "The burden of non-performing assets in India's thermal power sector:"
- la Rue du Can, S. de, Khandekar, A., Abhyankar, N., Phadke, A., Khanna, N. Z., Fridley, D., & Zhou, N. (2019). "Modeling India's energy future using a bottom-up approach." *Applied Energy*, 238, 1108–1125. <https://doi.org/10.1016/j.apenergy.2019.01.065>.
- Lawrenz, L., Xiong, B., Lorenz, L., Krumm, A., Hosenfeld, H., Burandt, T., Löffler, K., Oei, P.-Y., & von Hirschhausen, C. (2018). Exploring energy pathways for the low-carbon transformation in India—a model-based analysis. *Energies*, 11(11), 3001. <https://doi.org/10.3390/en11113001>
- Groissböck, M. & Gusmao, A. (2017). "Impact of high renewable penetration scenarios on system reliability: Two case studies in the Kingdom of Saudi Arabia". <http://arxiv.org/abs/1709.03761>.
- Palchak, D., Cochran, J., Ehlen, A., McBennett, B., Milligan, M., Chernyakhovskiy, I., Deshmukh, R., et al. 2017. "GREENING THE GRID: Pathways to integrate 175 gigawatts of renewable energy into India's electric grid, Vol. I—National Study." Vol. I.
- Palchak, J. D., Chernyakhovskiy, I., Bowen, T., & Narwade, V. (2019). "India 2030 wind and solar integration study: Interim report." Golden, CO (United States). <https://doi.org/10.2172/1524771>.
- Palmintier, B. & Webster, M. (2011). "Impact of unit commitment constraints on generation expansion planning with renewables." In *2011 IEEE Power and Energy Society General Meeting*, 1–7. <https://doi.org/10.1109/PES.2011.6038963>.
- POSOCO. (2019). "Fast response ancillary services (FRAS) implementation in Indian grid." [https://posoco.in/wp-content/uploads/2019/08/POSOCO\\_FRAS\\_Feedback.pdf](https://posoco.in/wp-content/uploads/2019/08/POSOCO_FRAS_Feedback.pdf).

- Ringkjøb, H. K., Haugan, P. M., & Solbrekke, I. M. (2018). A review of modelling tools for energy and electricity systems with large shares of variable renewables. *Renewable and Sustainable Energy Reviews*, 96, 440–459. <https://doi.org/10.1016/j.rser.2018.08.002>
- Spencer, T., Pachouri, R., Renjith, G., & Vohra, S. (2018). “Coal transition in India.” <https://www.teriin.org/sites/default/files/2018-12/Coal-Transition-in-India.pdf>
- Standing Committee on Energy. (2019). “43rd Report of Standing Committee on Energy.”

**Open Access** This chapter is licensed under the terms of the Creative Commons Attribution 4.0 International License (<http://creativecommons.org/licenses/by/4.0/>), which permits use, sharing, adaptation, distribution and reproduction in any medium or format, as long as you give appropriate credit to the original author(s) and the source, provide a link to the Creative Commons license and indicate if changes were made.

The images or other third party material in this chapter are included in the chapter's Creative Commons license, unless indicated otherwise in a credit line to the material. If material is not included in the chapter's Creative Commons license and your intended use is not permitted by statutory regulation or exceeds the permitted use, you will need to obtain permission directly from the copyright holder.





# Decentralized Electrification Pathways in Sub-Saharan Africa—Assessment of Experiences and Business Models

George Arende and Sofia Gonçalves

## Abstract

The transition to “SDG7 -modern and sustainable energy for all” may reconfigure the lives of citizens who live “outside the grid” in the rural communities in sub-Saharan Africa. The decentralization approach for developing renewable energy in sub-Saharan Africa has constantly been promoted as a means to rural electrification. This paper reviews the barriers to private sector participation in decentralized electrification projects and the solutions that have been proposed and implemented. It is not only the economic approaches that are analysed but also some of the solutions or drivers that have contributed to rural electrification. There are specific technological pathways which have proven fruitful in sub-Saharan Africa that are unique to its economic and demographic settings and that otherwise would not be adopted or used in developed countries. This paper finally analyses these technological pathways with the objective of matching the drivers and obstacles to potential solutions. Long term energy planning with the integration of regional power pools is instrumental to reduce CAPEX as well as to increase the market size. Blended financing together with already working technologies such as pay-as-you-go, and mobile money will be the pillars to meeting SDG7 goals.

---

G. Arende (✉) · S. Gonçalves  
EIT InnoEnergy, Stockholm, Sweden  
e-mail: [arende.delights@gmail.com](mailto:arende.delights@gmail.com)

S. Gonçalves  
e-mail: [sofiamoura.pgoncalves@gmail.com](mailto:sofiamoura.pgoncalves@gmail.com)

© The Author(s) 2023  
S. Groh et al. (eds.), *Electricity Access, Decarbonization, and Integration of Renewables*, Energiepolitik und Klimaschutz. Energy Policy and Climate Protection, [https://doi.org/10.1007/978-3-658-38215-5\\_8](https://doi.org/10.1007/978-3-658-38215-5_8)

---

**Keywords**

Rural electrification · Decentralized electrification · Solar systems · Mini grid · Sub-Saharan Africa

---

## 1 Introduction

Universal access to electricity is key for achieving the global sustainable development goals. According to the International Energy Agency (IEA, 2019), more than 600 million people in sub-Saharan Africa still do not have access to electricity (IEA, 2019). This includes 80% of the population in rural areas (IEA, 2019). The Sustainable development goal number 7 (SDG7) aims exactly at solving this problem by enabling the provision of access to affordable, reliable, clean, and sustainable energy globally for all by 2030.

Electricity supply in emerging and developing countries, specifically sub-Saharan Africa, is unreliable especially in rural areas, where frequently the maximum electric output of generators is completely used for consumption and where, at times, there are no capacity reserves be it primary, secondary, or tertiary reserves for flexibility management of such grids. This is a sharp contrast to the electricity systems in developed countries of the global North where the grids are transitioning from centralized to bi-directional with the onboarding of prosumers as well as Distributed Energy Resources (DER)<sup>1</sup>. Furthermore, the main purpose of distributed electrification in the developed countries of the global North is to improve resource efficiency, increase energy system resilience, and give individuals and communities a stronger role in decarbonization while achieving the renewable targets set by many governments. Currently, DERs only account for a small proportion of the European market but are predicted to outpace centralized capacity globally by more than 5-to-1 (Navigant Research, 2016). To eradicate energy poverty in sub-Saharan Africa, distributed renewable energy solutions can be a particularly good opportunity to increase energy access and help establishing a previously non-existent electricity market. This will also play a vital role in unlocking sustainable economic growth (Corfee-Morlot et al., 2019). Additionally, access to electricity can ensure better health and wellbeing.

---

<sup>1</sup> Distributed energy resources (DERs) are small or medium-sized resources that can potentially provide services to the power system, directly connected to the distribution network or near the end-user (European Commission, 2015).

Despite the electrification challenges, sub-Saharan Africa has multiple untapped renewable energy resources, having the largest global renewable energy potential. Taking solar as an example, the global irradiation average in this region is about 220 W/m<sup>2</sup> compared with 150 W/m<sup>2</sup> for parts of the USA, and about 100 W/m<sup>2</sup> for Europe and the United Kingdom (Renewable Energy in South Africa, 2021). Solar energy potential is estimated at 470 PWh for CSP and 660 PWh for PV (IRENA, 2014). Africa also has a wind potential of 460 PWh (IRENA, 2014). Hydro has a currently installed capacity of 37 GW which corresponds to only 11% of the total hydro potential. Consequently, sub-Saharan Africa has the highest untapped hydro potential with around 89% being underutilized (iha, 2020).

While it is becoming evident that renewables have a leading role to play in the electrification process of many countries in the region—including at small scale and off-grid—several challenges remain and there is not a straightforward solution due to the socio-economic complexities. These complexities are both on the supply and demand side. On the supply side they are insufficient technical capacity and poor utility performance in most of the rural areas. On the demand side these complexities can be insufficient uptake and low consumption which may discourage investments. The complexities also exist on the government's side when it comes to establishing appropriate regulations, attracting foreign investments, and setting clear targets. There is a need for capacity building in the form of financial literacy and educational campaigns to address some of these complex barriers. The local electricity market has been inaccessible to private-sector companies due to challenges such as market willingness to pay, high transactional costs for managing small loans, lack of clarity regarding leasing regulations for a non-financial institution. In addition, the rural consumers do not have any collateral to enable them to acquire financing from other institutions such as the commercial banks.

---

## 2 Aims & Objectives

This paper aims to:

1. Analyse the technical and socio-economic obstacles and drivers for the decentralized electrification for sub-Saharan Africa.
2. Explore the technological pathways and business approaches that are proven and successful.
3. Derive frameworks and conclusions for various parts of the system (supply to end consumers) based on a comparative analysis approach.



### 3 Methods

The study is based on a literature review of several case studies and academic papers about rural electrification in sub-Saharan Africa. Several of insights have been retrieved from reports by renowned organizations such as International Renewable Energy Agency (IRENA), The World Bank and the International Energy Agency. The assessment evaluates drivers for success and obstacles that countries and regions are likely to face.

This paper also dives deep into the emerging technological pathways that have been implemented as well as regional and country specific responses on the market and policy sides. Furthermore, an investigation of business models that have proven to be successful in certain cases is provided.

---

### 4 Electrification Barriers

The obstacles identified can be broadly categorized into four major categories: Market, Technical, Financial and Regulatory Barriers.

One of the biggest market obstacles is low Market Willingness To Pay (MWTP)- where consumers are not sufficiently informed regarding the value of electricity and that by paying for it, they enable provision of continuously running electricity services. Some effects of this are illegal connections to the grid or theft of power. Another market obstacle is low electricity uptake, where in most cases, consumers do not see the urge or the need to be connected to the grid even though distribution lines could be a few meters from their homes (Blimpo & Cosgrove-Davies, 2019). The connection charges and the complete process of getting connected are an entry point barrier because connection charges are high in comparison to income levels (Blimpo & Cosgrove-Davies, 2019). There is a lack of proven business models since most of the adapted economic strategies are relatively new. For private financiers, the risk return profile of a project is a determinant as to whether they should fund it or not. Such investors want to get a return proportional to the risk they undertake. Renewable energy projects are affected by foreign exchange risks as well as due to their novelty and short track record. As a result, local financial institutions do not have expertise on how to mitigate currency volatility and heavy reliance on foreign finance (UNEP, 2012). Finally, there is the diminishing utilities factor: connecting more consumers to the existing grid without creating new infrastructure implies higher maintenance costs and low profit margins and at times even losses (Blimpo & Cosgrove-Davies, 2019).

Technical obstacles are mostly driven by the dysfunctional and poor state of existing infrastructure in electricity grids. One reason for this is lack of planning from governments, with no progressive approach combining various delivery modes and harnessing digitalization trends where needed. Electricity together with digital technology is now considered a general-purpose technology (GPT). Digitizing the electrical grid leads to automated technology and analytics that can influence consumption and contribute to new customer services. Digitalization can improve reliability which then improves trust from customers (Blimpo & Cosgrove-Davies, 2019). Another technical obstacle is high rural connection costs due to geographical preconditions. Most countries in sub-Saharan Africa are large in geographical land size with spread but concentrated population settlements, where a majority of households does not meet minimum building connection standards as they have not been built with electrification plans in mind. This can be in part solved by creating regional power pools. National grids in many sub-Saharan countries have not been able to deliver reliable power supply at affordable prices to their citizens. Governments have therefore been interested in regional multi-lateral and bilateral agreements that emphasize coordination and combine their resources to create a more robust regional grid involving cross-border interconnections as well as electricity exchange and trade that can be traced (AfDB, 2011). Cross border transmission has a potential to lower costs and stimulate investments. It may increase trade volumes addressing lack of market challenge. Investments can then be paid up quicker, as more people get connected to the grid (Eberhard et al., 2011). Consequently, it can lead to an increase in market size as well as reducing CAPEX for grid/distribution infrastructure and the system operational costs (AfDB, 2011).

Thirdly, the financing obstacle has been a big barrier to decentralized electrification in sub-Saharan Africa. There is a lack of capital needed to build generation and transmission infrastructure. The region faces an annual infrastructure financing gap of 68–108 billion USD (AfDB, 2019), including electricity distribution grid costs. Unfortunately, there are limited regional financial instruments and institutions that can support such infrastructure. This leads to another problem. Since most of the grid generation and distribution infrastructure are not manufactured or produced within the continent, importing them from other parts of the world results in high CAPEX for investments.

Lack of regulation is the fourth major electrification barrier. Legitimate businesses may find it difficult to operate and compete with informal markets. These sell products such as solar PV home modules—typically with low-quality standards and in some cases smuggled into the country. They also do not pay any taxes or incur an administrative cost. As a result, they tend to be cheaper and, hence, more appealing to local customers. This in turn locks out potential legitimate com-

petitors. In certain circumstances, there may also be political manipulation of prices, especially in countries where electricity prices are subsidized by the government. As a result of locally vested interests defending the status quo, private investments may face adversities regarding cost coverage. Bolivia may serve as an illustrative example, where electricity prices increased due to reforms in the subsidy percentages, and this resulted into a public backlash against the reform (E. Besant-Jones, 2006). As much as some of the political risk may seem vague, trends like political sabotage, expropriation and monopoly by national utilities are still a common phenomenon (UNEP, 2012). There are, in theory, possibilities for new coming prosumers or commercial consumers to obtain bank loans from commercial banks to finance installation of distributed solar PV modules. However, commercial banks are usually not interested in issuing such loans because transaction costs for managing them are too high compared to expected returns. Costs involved in the administration and management of such small loans are usually in the range of 50 to 200\$ (ECA, 2018). Also, given the absence of lending history for such decentralized electrification products, their risk profile is perceived to be high (ECA, 2018).

From the regulatory perspective, standardization is needed for fair competition. It is exceedingly difficult for companies to enter, operate and compete in an economy where the electricity tariffs are fully regulated by the government. The wholesale electricity prices are normally high while the regulated retail tariffs are low (Blimpo and Cosgrove-Davies 2019).

Finally, there is lack of laboratory and R&D facilities or skilled knowledge for testing and inspection to approve the quality of such products. Also, there is no government entity or a regulatory body to control the quality of products supplied in such markets.

---

## 5 Drivers

Electrification in sub-Saharan Africa has partly been driven by stakeholder initiatives such as NGOs and Development Corporations. A strong example of such initiatives is Power Africa, an initiative led by United States Agency for International Development (USAID) with the aim to bridge the financial gap and double electricity access for millions of people in sub-Saharan Africa. Since the launch of Power Africa, the African Development Bank in cooperation with the World Bank Group and the Swedish government through the Swedish development corporation (SIDA), have committed cumulatively over nine billion dollars in support of electrification in Africa (AfDB, 2019). Another example is the Interna-

tional Finance Corporation (IFC) which established a leading position promoting private sector investment in Africa. Over six decades, IFC has invested more than \$25 billion in African businesses and financial institutions, with the current portfolio exceeding \$5 billion (IFC, 2021).

On a similar front, NGOs such as Lighting Africa, whose aim is to catalyse markets to deliver affordable, high-quality off-grid lighting and energy products such as solar home systems, have made a contribution. Lighting Africa has already enabled 32.3 million people across Africa to meet their basic electricity needs such as lighting and phone charging through quality verified solar off-grid products (Lighting Africa, 2021).

As explained previously, the region's ability to attract global commercial financing to tackle challenges is hampered by the high perceived risks of investing as well as a lack of scalable investment opportunities. To reduce the perceived risks, there is a need of de-risking private debt funds by combining them with impact financing. Such an innovative financing has been termed as blended financing. Blended financing is proving to be instrumental to incentivize commercial investors to invest in small and medium companies working towards sustainable infrastructure projects. Blended finance is the use of catalytic capital from public or philanthropic sources to de-risk transactions and improve their risk-return profile allowing for increased private sector investment (Wamicwe, 2020). Illustrative blended transactions include the Universal Green Energy Program by Deutsche Bank which has raised \$302 m to increase access to clean energy in sub-Saharan Africa, especially for rural populations (Wamicwe, 2020). It is estimated, this instrument could bridge the 2.5 trillion dollar per year of the investment gap in need for electrification in sub-Saharan Africa. In 2018, DFI blended concessional finance projects saw a more than 70% increase in the total volume of projects financed with an increase in private mobilization and doubling in growth in the low-income countries (DFI, 2020).

On the technologies perspective, the falling photovoltaic (PV) costs have been an enabler to electrification in sub-Saharan Africa. Solar PV costs decreased by roughly 77% between 2010 and 2018 according to the International Renewable Energy Agency (Schwerhof & Mouhamadou, 2020). The development of Unstructured Supplementary Service Data (USSD) has been leveraged with the accessible photovoltaic technology to revolutionize electrification in sub-Saharan Africa. In an ecosystem where mobile connectivity is higher than access to affordable electricity (44% of the population has mobile subscription (GSMA Intelligence, 2019) against 80% with no access to electricity (IEA, 2022)), there has been a huge development, since 2013, on the so called USSD. USSD has enabled the development of mobile money that is revolutionizing access to financial ser-

vices and therefore to electrification in the region. USSD is an advanced mobile technology that allows its users to perform transactions or banking without using the internet. This is made possible since USSD is an interface that links the merchant account and the user through a telecom operator. The users are therefore able to use banking features through short messages (SMS). Mobile payments, using USSD, allows users to receive, withdraw, and send money without being connected to the formal banking system, just between cell phone devices. It has been adapted to serve numerous operator functions and value-added services. This has high relevance in rural areas with limited network access or with no internet connection, as it enables the rapid proliferation of mobile payments. It has been the key driver for pay-as you-go (“PAYG”) business models, allowing low-income customers to pay off their purchases over an extended period. The PAYG business model emerged to provide electricity generated from Distributed Energy Resources (DER) at affordable prices and between 2015 and 2020, around eight million people gained energy access globally through it. The package usually includes a solar home system that customers pay for by using mobile payment technologies and mobile phone credit. An energy service provider rents or sells solar PV systems in exchange for regular payments through mobile payment systems. This also has benefits for energy companies that are able to reduce operational costs that would be incurred in physical collection of fees.

Financially, the incorporation of PAYG financing through mobile money has driven electrification in sub-Saharan Africa enabling consumers to pay in periodic instalments. It has also made it possible to incorporate smart metering and data analytics. Small businesses owners have often been forced to adopt solar photovoltaic technologies for electrification due to unreliable grid power supply which experiences frequent load shedding. Solar off-grid electricity suppliers are also more affordable than the electricity tariffs of the utilities, especially Energy Service Companies (ESCOs) offering aPAYG model. The switch to mini grids will be more beneficial and make more sense to entrepreneurs who in average experience 31% losses in sales due to power outages and lack of reliable supply to their businesses (World Bank, 2019).

Finally, electrification in sub-Saharan Africa is sometimes fuelled by the development of specific purpose infrastructure for critical needs such as hospitals, military bases that have in turn led to the development of microgrids and nano-grids. A case example was in Tanzania where the Bulongwa minigrad which was initially constructed exclusively to provide power to the Lutheran hospital enabled villagers to access electricity through standardized power producer’s agreement (SPPA) since the generation from the minigrad was beyond the hospital’s consumption (Ngowi et al., 2019).

## 6 Technological Pathways

Micro-grids and mini-grids, stand-alone solar off-grid systems and other technological solutions have become commercially viable and climate resilient to provide access to clean energy in sub-Saharan Africa. 40 million out of 315 million people in rural Africa that will gain access to electricity will be served by mini grids by 2040 according to the International Energy Agency Energy outlook for sub-Saharan Africa (PWC, 2016). In accordance with the SDG7, connecting 500 million people in sub-Saharan Africa by 2030 would require more than 210,000 mini grids and a total investment of around 220\$ billion. The current cost of solar hybrid mini grid is 0.55 \$/KWh, and to become economically more attractive across geographies, needs to be reduced to 0.22 \$/KWh by 2030 (World Bank, 2019). This will make the LCOE of Hybrid mini grids (at load factor of 40%) less than the LCOE of 24 of the 39 Utilities in Africa. Mini grids have already been implemented in countries like Kenya, Nigeria and Ethiopia and have proven to be successful. According to the World Bank more than 700,000 standalone solar systems have been installed in sub-Saharan Africa so far, ranging from lanterns to solar home systems (SHS). These systems are now driving a new market segment called PULSE (Productive Uses Leveraging Solar Energy) Systems applications. The most common PULSE appliances are water irrigation pumps, grain milling machines, cooling, and refrigeration and agro-processing, all powered by solar. A good example of PULSE application is a solar maize mill which can be used in rural areas and is an attractive option for remote farmers, bringing higher return on investment than a diesel generator after two years of use (Clean Energy Solutions, 2020). Currently, the estimated serviceable market for PULSE applications is around 734 million dollars with the potential to soar to 11.3 billion dollars in the future (Lighting Global 2021). Standalone Solar PV systems have proven to be cheaper than the costs of running diesel generators. For example, in Nigeria customers of Lumos (the largest provider of off-grid solar in Nigeria), are now paying only 15 \$ a month instead of relying on diesel generators whose fuel costs are around 70 \$ per month (Silverstein, 2019).

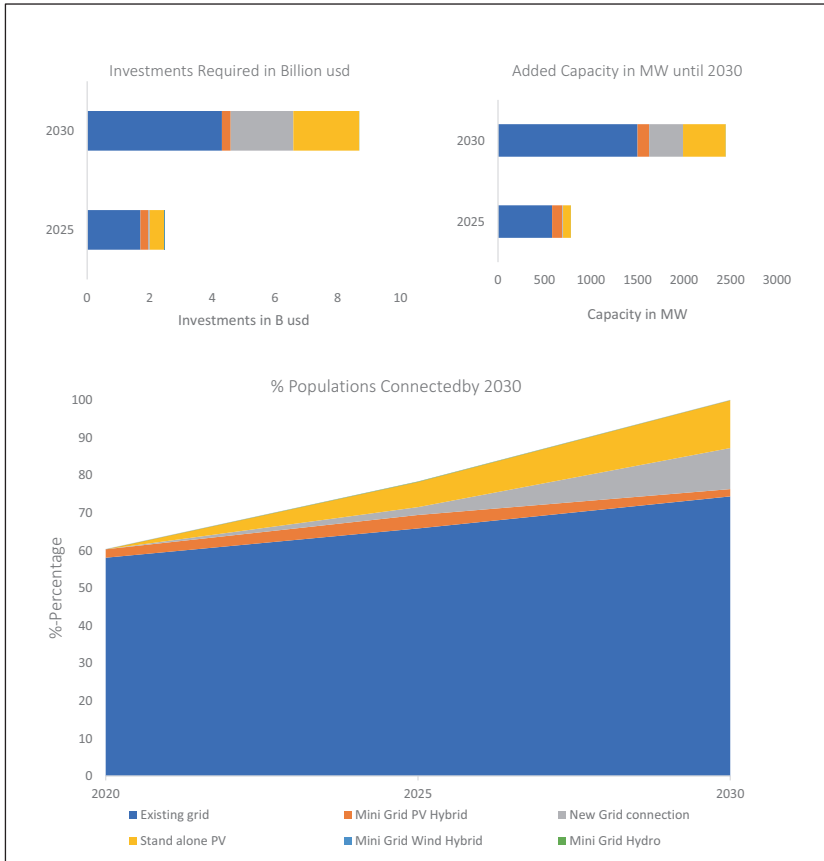
Different business approaches have been exploited to tackle electrification in sub-Saharan Africa and within the electrification value chain, entities can play distinct roles: manufacturers of electrification components, financiers, installers and DESCOs:

- Financiers could be impact investors that accelerate, scale, and improve deployment of capital in the decentralized electrification sector. Some players identified in that sector are CrossBoundary (CrossBoundary, 2021) and Responsibility (responsibility, 2021).

- Manufacturers mostly develop the hardware and then partner with local organizations for distribution. An example for this case would be Solaris, a start-up that offers modular solar home systems with integrated PAYG technology in Tanzania to more than 10 K customers. Some manufacturers also take the role of installers. Some installers do not operate the grid but instead train local communities to do it. An example is a start-up called Bennoo which through their Enterprise resource management software helps local entrepreneurs manage micro-grids by acting as an energy agency. Bennoo working in Djekloue, Togo has installed their system in 75% of the households reaching it to almost 220 families.
- Finally, Distributed Energy Service Companies (DESCO's) build a customer relationship by installing assets such as solar home systems or connections to mini grids at or near dwellings and small businesses. DESCOs then collect an on-going payment for energy (or recurring fees) from the customer (PAYG model), eliminating upfront costs thereby addressing the issue of affordability for households. DESCO has been proven to be a business model that provides return on investment.

Not only solar technologies are contributing to the transition of Africa in access to clean energy, but three modelling tools have been identified to play a role to electrification in sub-Saharan Africa. The focus areas for the tools can broadly be classified as monitoring of policy frameworks, creation of investment scenarios and finally country and regional long-term energy planning scenarios. The three tools are as summarized below:

1. RISE (Regulatory Indicators for Sustainable Energy): This is a tool designed specifically to monitor the status of policy frameworks to advance modern and renewable energy in the developing world. (Strasser et al., 2018).
2. OnSSET (Open-source Spatial Electrification Tool): It has been used to generate 216 electrification investment scenarios per country for sixty countries in Sub Saharan Africa, Central America, Asia, and the Pacific. This tool has been the basis of the UNDESA modelling tool for universal access to electricity. The same tool has also been used as the basis for the World Bank's Global Electrification Platform (GEP) (GEPE, 2021). The major electrification pathways are increasing investments into the existing grid, stand-alone PV and new grid connections. Figure. 1 shows that achieving 100% universal electricity access targets in Kenya will be achieved by doubling investments in the existing grid, increasing the investments in stand-alone PV by a magnitude of 5. An investment of around 3.6 billion USD would be required in new grid connections and stand-alone PVs, which are the major pathways in achieving global elec-



**Fig. 1** Open-source spatial tool depicting electrification scenario in Kenya. (Source: [www.electrifynow.energy.data](http://www.electrifynow.energy.data); ONSSET.ORG (2022))

trification by 2030, followed by an investment of around 2 billion USD into the existing grid. An increase in capacity of roughly 1.6 GW of power is needed to achieve the electrification targets, mainly contributed to by stand-alone PV with new grid connections.

3. OSeMOSYS (Open-Source Energy Modelling System): It is a full system optimization model for long-term energy planning. It was featured as one of the United Nation’s Modelling Tools for Sustainable Development. This tool calculates the least-cost of electricity, energy, and resources supply options for



countries all over the world. From this it is possible to evaluate and decide the necessary investments and their timeframe and location (OSeMOSYS, 2021).

All the tools mentioned are open-source, and simple energy modelling tools, readily accessible for researchers and decision makers from developing countries. This offers an alternative for energy policy makers and analysts from governments with limited resources and funding, to develop investment scenarios or even to be able to create longterm energy plans and roadmaps on how they want to develop the electrification infrastructure in a majority of the sub-Saharan countries.

---

## 7 Conclusions

Obstacles can be categorized on what part of the electrification value chain they are encountered. On the supply side there are both technical as well as financial obstacles. Poor and dysfunctional infrastructure can be in part answered by applying modelling tools for long term energy planning. Poor utility performance which is a market obstacle as it results into low revenues can be solved by the creation and integration of regional power pools which will reduce the CAPEX for grid and generation infrastructure and increases the market size.

From a governance perspective, lack of appropriate regulations and no clear electrification targets from the government are regulatory obstacles which can be solved by using free and open-source modelling software such as OseMOSYS for long term planning. RISE can be used for regulation tracking and monitoring. Also, the government should lead in attempts to attract and de-risk foreign investments which can be achieved by promoting blended financing instruments.

Finally, on the demand side, market obstacles such as insufficient uptake and low consumption can be addressed by raising awareness campaigns and education on the benefits of electrification. Demonstrating the benefits of adopting stand-alone solar off-grid systems and PULSE applications (such as irrigation systems and pico-devices) to local communities, farmers and small business owners will increase adoption as well. Also, if more energy companies adopt the DESCO model and offer a PAYG model option to local energy communities and small business owners, the main pain point of high upfront electrification costs will be decreased. For the 600 million people who live without electricity—80% of who live in rural areas—governments need to do more, and they need to do it better. There is not a one-size-fits-all solution, but there are positive changes (in technology, policy, and financing) happening that are transforming lives and increasing access to clean energy. To bridge the gaps in sub-Saharan Africa, it is necessary to focus on the actual people

who lack connections, those who are unable to pay for electricity services despite being connected, those with illegal connections, and those with unreliable or insufficient supply. Without this in mind, SDG7 and other development goals that rely on the availability of electricity will remain a distant reality.

---

## References

- AfDB. (2011). *Regional power status in African power pools*. Status Report, Infrastructure Consortium for Africa (ICA), Tunis Belvédère.
- AfDB. (2019). *African economic outlook 2019*. African Development Bank.
- Bahia, K., & Stefano, S. (2019). *The State of Mobile Internet Connectivity 2019*. London: GSMAIntelligence.
- Besant-Jones, J.E. (2006). *Reforming the power markets in developing countries*. World Bank.
- Blimpo, M. P., & Cosgrove-Davies, M. (2019). *Electricity access in Sub-Saharan Africa*. The World Bank.
- Clean Energy Solutions. (2020). Lighting Global. <https://cleanenergysolutions.org>. Accessed 20 Apr 2021.
- Corfee-Morlot, J., Parks, P., Ogunleye, J., & Ayeni, F. (2019). *Achieving clean energy access*. OECD.
- Crossboundary. (2021). Crossboundary. <https://www.crossboundary.com/>. Accessed 28 Apr 2021.
- DFI. (2020). *DFI working group on blended concessional finance for private sector projects*. Joint Report.
- Eberhard, A., Rosnes, O., Shkaratan, M., & Vennemo, H. (2011). *Africa's power infrastructure, investment, integration, efficiency*. The World Bank.
- ECA. (2018). *Off-Grid solar market assessment*. World Bank Report, Economic Consulting Associates Limited, Maputo.
- European Commission. (2015). *Study on the effective Integration of Distributed Energy Resources for providing flexibility to the electricity system*. Stockholm: European Commission.
- Howells, M., Rogner, H., Strachan, N., Heaps, C., Huntington, H., Kypreos, S., ... & Roehrl, A. (2011). OSeMOSYS: the open source energy modeling system: an introduction to its ethos, structure and development. *Energy Policy*, 39(10), 5850-5870.
- Hafner, M., Tagliapietra, S., & De Strasser, L. (2018). *Energy in Africa: Challenges and opportunities* (p. 112). Springer Nature.
- IEA. (2019). *Energy outlook, a focus on the prospects of Sub-Saharan Africa*. WEIA.
- IFC. (2021). IFC's priorities in Sub-Saharan Africa. [https://www.ifc.org/wps/wcm/connect/regionext\\_content/ifc\\_extenal\\_corprate\\_site/sub-saharan+afrika/priorities/priorities](https://www.ifc.org/wps/wcm/connect/regionext_content/ifc_extenal_corprate_site/sub-saharan+afrika/priorities/priorities). Accessed 20 Apr 2021.
- iha. (2020). *Hydropower status report, sector trends and insights*. International Hydro-power Association.
- IRENA. (2014). *Estimating the renewable potential in Africa, a GIS based approach*. Working Paper, International Renewable Energy Agency, Abu Dhabi.
- Lighting Global. (2021). <https://www.lightingglobal.org/pulse/>. Accessed 20 Apr 2021.

- Lighting Africa. (2021). About us. <https://www.lightingafrica.org/about/>. Accessed 20 Apr 2021.
- Navigant Research. (2016). Installed distributed energy resources capacity is expected to total \$1.9 trillion in investment from 2015 to 2024, according to navigant research. <https://www.businesswire.com/news/home/20160802005683/en/Installed-Distrib%E2%80%A6>. Accessed 17 Apr 2021.
- Ngowi, J. M., Bångens, L., & Ahlgren, E. O. (2019). Benefits and challenges to productive use of off-grid rural electrification; The case of minigrid in Bulongwa-Tanzania. *Energy for Sustainable Development* 1–4.
- ONSSET.ORG. (2022). Global electrification platform. <https://electrifynow.energydata.info/explore/ke-2>.
- PWC. (2016). Electricity beyond accelerating access to power for all. Renewable Energy in South Africa. <https://www.pwc.com/gx/en/energy-utilities-mining/pdf/electricity-beyond-grid.pdf>. Accessed 20 Apr 2021.
- responsAbility. (2021). responsAbility. <https://www.responsability.com/en>. Accessed 28 Apr 2021.
- Schwerhof, G., & Mouhamadou, S. Y. (2020). Renewable energy sources, especially solar, are ideal for meeting Africa's electrical power needs. p.54-57. <https://www.imf.org/en/Publications/fandd/issues/2020/03/powering-Africa-with-solar-energy-sy>. Accessed 4 September 2022.
- Silverstein, K. (2019). Forbes -Off-Grid solar power is making Africa's emerging economies a little brighter. 08 19. <https://www.forbes.com/sites/kensilverstein/2019/08/19/off-grid-solar-power-is-making-africas-emerging-economies-a-little-brighter/>. Accessed 2 March 2021.
- UNEP. (2012). *Financing renewable energy in developing countries; Drivers and barriers for private finance in Saharan Africa*. A study and survey by UNEP. Instprint.
- Wamicwe, P. (2020). How blended finance can accelerate MSME growth in Africa. 08 31. <https://www.theafricareport.com/39877/how-blended-finance-can-accelerate-msme-growth-in-africa/>. Accessed 3 Feb 2021.
- World Bank. (2019). *Mini grids for half a billion people. Market outlook and handbook for decision makers*. Technical Report, Washington DC, World Bank.

**Open Access** This chapter is licensed under the terms of the Creative Commons Attribution 4.0 International License (<http://creativecommons.org/licenses/by/4.0/>), which permits use, sharing, adaptation, distribution and reproduction in any medium or format, as long as you give appropriate credit to the original author(s) and the source, provide a link to the Creative Commons license and indicate if changes were made.

The images or other third party material in this chapter are included in the chapter's Creative Commons license, unless indicated otherwise in a credit line to the material. If material is not included in the chapter's Creative Commons license and your intended use is not permitted by statutory regulation or exceeds the permitted use, you will need to obtain permission directly from the copyright holder.





# Identifying Effective Electrification Approaches and Combinations Thereof to Meet Universal Electricity Access Targets in Eastern Africa

Charles Muchunku and Georg Heinemann

## Abstract

The gains made in increasing electricity access between 2010 and 2018 indicate the benefit of a multi-pronged approach to electrification, which combines on-grid and off-grid electrification approaches and efforts from both public and private actors. The gains still fall short of the rate of increase needed to achieve universal access to electricity by 2030, indicating the need to increase the effectiveness of the multi-pronged approach. To do this the paper applies the triple embeddedness framework theory. Within the scope of Eastern Africa, we consider actors in the delivery of electricity access (irrespective of approach or whether public or private) as delivering similar goods and services, and conceptualize them as a collective entity i.e., firms in the electrification industry. The paper then analyses how these firms are shaped by the industry regime and influenced by the socio-political and economic environments, with a view to identifying where and how external pressure can be exerted to stimulate and facilitate the reorientation and recreation required to make progress towards universal electricity access. Through this exercise we demonstrate that the triple embeddedness framework provides a structured

---

C. Muchunku  
Nairobi, Kenya

G. Heinemann (✉)  
TU Berlin, Berlin, Germany  
e-mail: [gh@wip.tu-berlin.de](mailto:gh@wip.tu-berlin.de)

way of laying out the key aspects associated with electrification to create a picture that enables one to ‘see the forest for the trees’ and identify where and how to achieve more effective complementarity between on and off-grid approaches, and public and private firms.

---

**Keywords**

Business models · Delivery models · Electrification · Energy access · Institutional economics · Off-grid

---

## 1 Introduction

The Sustainable Development Goal Target 7.1 sets out the global goal for universal access to affordable, reliable, sustainable, and modern energy services by 2030. The target covers access to electricity (7.1.1) and access to clean cooking (7.1.2). Recent years have seen rapid growth in access to electricity after accelerated deployment of affordable electrification options, consisting of both on- and off-grid solutions. While the global population lacking access to electricity dropped from 1.2 billion in 2010 to 789 million in 2018, these gains fall short of the annual rate of increase needed to achieve universal access to electricity by 2030. The world’s electricity access deficit is increasingly concentrated in Sub-Saharan Africa; under current and planned policies before the start of the COVID-19 crisis, it is estimated that about 620 million people will remain without access in 2030, 85% of them in Sub-Saharan Africa (International Energy Agency et al., 2020).

The gains made in increasing electricity access indicate the benefit of a multi-pronged approach to electrification. However, to increase the effectiveness of such an approach, it is necessary to understand how different electrification approaches and actors are interconnected and complementary. This suggests a shift from categorizing electrification actors i.e., by public or private, or categorizing electrification approaches (i.e., grid, mini-grid, or off-grid solar) and analysing the categories separately. Instead, a broader understanding of the ‘electrification industry’ is required. This includes, (1) an understanding of the firms in the electrification industry, their roles and influence with regard to shaping regime rules, (2) the economic and socio-political environment in which the firms in the electrification industry operate and how they respond to the pressures created by this environment, and (3) identifying where and how external pressure

can be exerted to stimulate and facilitate the reorientation and recreation required by firms in the 'electrification industry' to make progress towards the goal of universal electricity access.

---

## 2 Literature Review

To better understand what is involved in addressing societal problems through substantial industry reorientation, Frank Geels developed the Triple Embeddedness Framework (TEF) (Geels, 2014). The TEF was developed to provide a broad understanding of co-evolution of industries and their environments, and to conceptualize specific causal mechanisms. It aims to unravel the complexity of co-evolution of industries and their environments by distinguishing mechanisms through which different environments exert pressure on firms, strategies firms can use in response to these pressures, and regime elements which enable and constrain the perceptions and strategies of firms-in-industries. This paper aims to apply this framework to the electricity access challenge in Eastern Africa.

Other frameworks, notably the multi-level perspective, have been used to analyse the electricity access challenge in countries in sub-Saharan Africa. Bhamidipati et al. uses the multi-level perspective to investigate the role of transnational actors in the development of the off-grid solar PV (OGS) regime in Uganda, they develop a typology of transnational actors and examines their roles in mobilizing the flow of knowledge, capital and technology towards shaping the country's OGS rural electrification regime, and demonstrates the transnational nature of regime development by discussing the role of foreign actors, their underlying motives and shifting importance over time (Bhamidipati et al., 2019). Sergi et al. (2018) also uses the multi-level perspective to illustrate the interactions between state policies, investment in off-grid technologies, and expansion of electricity access. He examines the institutions in the Kenyan and Tanzanian electricity sectors, undertakes a quantitative analysis of investment and development aid transaction data for on-grid and off-grid projects, and demonstrates that these investments reveal the priorities and constraints of different actors across on and off-grid technologies.

Also of value is literature that considers multi-pronged approaches to electricity access and analyses the different environmental pressures exerted on firms delivering electricity access (even though the analysis is not done using a specific theoretical framework).

Using the history of electrification in South Africa, Gaunt demonstrates that electrification has been implemented to meet three significantly different objectives: initially economic, later socio-economic, and recently social. He determines that while different solutions are needed to achieve the different electrification objectives, this was not evident because existing processes, networks, tariffs, and regulations had developed around concepts of electrification driven by economic objectives. He concludes that the experience of electrification in South Africa indicates that identifying the differences between economic and social objectives, and their effect on electrification, electricity tariffs, electricity distribution industry restructuring and regulation, should contribute to better decision-making and greater effectiveness in future (Gaunt, 2005).

Levin et al. argues that the emergence of lower cost distributed technologies has created a fundamental shift in how energy services are being consumed, and that developing countries have a unique opportunity to leapfrog the traditional centralized model and achieve universal electricity access by transitioning to a more distributed approach to electrification (Levin & Thomas, 2016).

Drawing on lessons from successful electrification programs, Barnes shows that complementary solutions, involving both grid and off-grid approaches will be needed for electrification in developing countries. Grid extension should be pursued as a least-cost option in more densely populated and economically advanced areas, where power demand and load densities are high, and where grid extension is not least-cost or reaching remote communities through grid network expansion is economically impractical, off-grid technologies and business models should be adopted to provide basic levels of electricity service (Barnes, 2011).

Urpelainen describes three approaches to electrification and uses India as a case study to illustrate these. These approaches are (1) complete separation, in which off-grid electrification is pursued by private entrepreneurs and designated government agencies in areas that are currently not planned for grid extension, (2) uncoordinated integration, in which both grid extension and off-grid electrification are pursued independently of one another by different agents within and outside the government, and (3) integrated development, in which a consistent electrification policy guides the progress of coordinated off-grid electrification and grid extension. She concludes that explicit integration is the most effective because it prevents coordination failure. She argues that as long as there are ongoing grid extension efforts and offering power to some segments of the rural population through the grid would be expensive, off-grid electrification is a potentially useful complement to the conventional approach (Urpelainen, 2014).

Pedersen et al. investigates the practices and business approaches of private mini grid developers in Kenya. The paper's analytical focus is how private

mini grid developers are influencing the electrification regime to strengthen and expand the niche for private mini grids (Pedersen & Nygaard, 2018).

Bhattacharyya reviews funding needs and financing mechanisms for off-grid electrification to find whether the funding for these activities has been adequate, whether sufficient funding is likely to be available to meet the needs of universal energy access, and whether innovative approaches can be used in funding. He finds that the size of investment required is significantly higher than traditional levels for energy access provisions, and that development assistance will not be sufficient. He concludes that developing country governments and private sector will have to play a significant role. Governments will have to commit funds and create an enabling environment for private businesses, micro-finance organizations, and for the management and implementation of energy access activities in a timely and orderly manner (Bhattacharyya, 2013).

---

### 3 Methods

This paper considers actors in the delivery of electricity access (irrespective of approach or whether public or private) as delivering similar goods and services. This enables us to then conceptualize them as a collective entity i.e., firms in the electrification industry, and then ask the broader question—What shapes and influences the electrification industry? The paper focuses on the electrification industry in Eastern Africa, primarily considering Kenya, Ethiopia, Uganda, Tanzania, and Rwanda. We then apply Geels's Triple Embeddedness Framework (TEF) theory, which argues that firms are shaped by industry regimes and influenced by external environments (i.e., economic and socio-political), to answer this question (Geels, 2014).

The paper is divided into four sections. The first section identifies and describes firms in the electrification industry. The TEF distinguishes firms in industries into three types: core firms (which have the power to discipline other firms and shape regime rules to suit their interest), firms 'in the middle', and peripheral firms (fringe actors or new entrants for whom it is relatively easier to deviate from regime rules) (Geels, 2014). The second section describes what shapes the firms in the electrification industry i.e., the industry regime. This includes their core capabilities e.g., technical knowledge and competency, shared mindsets—that shape interpretations of external environments and influence strategic choices and decisions, industry mission and identity—beliefs that actors have about themselves and their role in society, and regulations, laws, and standards—that shape electrification markets and innovation activities and reduce the



set of choices available to firms in the electrification industry. The third section describes the socio-political and economic environments that firms in the electrification industry are operating in and how they are strategically responding to these environments i.e., how they are positioning themselves within this environment, attempting to shape the environment or reorienting and/or recreating themselves to fit better within it.

The fourth section synthesizes and analyses the previous sections to identify if, where and how external pressure can be exerted to stimulate and facilitate the reorientation and recreation required by firms in the ‘electrification industry’ to make progress towards the goal of universal electricity access. Reorientation involves substantial changes in technology and market strategy, while recreation additionally entails substantial changes in core beliefs and values (i.e., a foundational rethink). Reorientation of firms requires increasing pressures from economic and socio-political environments, without which firms are likely to be locked-in to existing industry regimes (Geels, 2014).

The paper is based on information sourced from: (1) the electrification strategies and plans for the five Eastern African countries under consideration, which detail the institutional environment and anticipated roles of public and private firms in electrification, (2) primary and secondary legislation relevant to electrification (2) off-grid solar market trend reports—a series of biennial assessments of the global off-grid solar market that provide information on the market environment for off-grid solar, the landscape of private firms and how they are responding to external pressures, (3) implementation reports for public electrification projects funded by the World Bank and governments, which provide information on how public firms are responding to external pressures, (4) other off-grid solar and mini grid market reports and (5) academic literature on electrification in sub-Saharan Africa and literature that analyses different electrification approaches.

---

## **4 Results**

### **4.1 Firms in the Electrification Industry**

In the 1990’s, as a result of the power crisis facing many countries, development finance institutions prompted governments to adopt a set of standardized power sector reforms with the offer of conditional financing. The need for reforms arose from two primary concerns: dissatisfaction over the poor technical, financial, and managerial performance of the state-owned electricity utilities, and the inability of utilities and the government to mobilize sufficient investment capital for

the electricity subsector's development and expansion (Bacon & Besant-Jones, 2002). The five major reform options implemented in sub-Saharan Africa include: (1) unbundling/restructuring—the process of separating vertically integrated utilities into independent generation, transmission and distribution companies, (2) management contracts—contracting out the management of a utility to a private entity with the utility remaining the owner of the assets, (3) corporatization/commercialization—transforming a state-owned utility into a limited liability corporate body often with the government as the main shareholder, (4) independent power producers (IPPs)—creating an opportunity for private sector investment in the wholesale power market by e.g., providing for long-term power purchase agreements backed by suitable guarantees, (5) electricity law amendment—to e.g., remove the monopoly of the national utility—a major barrier to private sector participation, provide for the establishment of an independent regulatory body for the electricity subsector, and create a provision for a rural electrification programme and/or fund.

Power sector reform is the origin of national electricity utilities and rural electrification agencies in many countries in sub-Saharan Africa today. The key objective of corporatization was to ensure that utilities ran their operations to maximize profits by adopting principles such as: separating the utility from the ministry, creating a clear accounting framework, cost recovery in pricing, reducing, or eliminating subsidies, and enforcing revenue collection. Rural electrification agencies were essentially established because these principles of profit maximization were incompatible with rural electrification, which aims to provide affordable electricity services in areas often characterized by low population density, lower incomes, low electricity consumption and high operating costs. Once electricity utilities were corporatized, it was no longer possible for governments to depend on them to achieve their rural electrification objectives.

Until recently there has been little coordination in Eastern Africa between rural electrification agencies, national electricity utilities and private firms to deliver electricity access. Historically, governments have focused on grid-based approaches (and diesel-powered mini grids to a lesser extent) implemented using public funds and through rural electrification agencies and national electricity utility companies. Where rural electrification agencies and national electricity utilities government have been unable to provide electricity connections and reliable electricity services, private sector has used this as an opportunity for value creation; commercially offering off-grid solar products and electricity services through renewable energy based mini or micro-grids.

The firms in the electrification industry can be categorised as follows:

### 4.1.1 Rural Electrification Agency

Typically, a dedicated government agency responsible for developing and monitoring rural electrification plans, as well as managing the rural electrification process and the funds dedicated for rural electrification. Their tasks include prioritizing areas for electrification, determining the electrification technology options to use based on their suitability for different areas, and clustering of electrification projects to optimize economies of scale. Kenya, Uganda, and Tanzania have established government agencies that are dedicated to rural electrification agencies. Although structured differently, Rwanda is similar, rural electrification is implemented as a program (the Energy Access Rollout Program (EARP)), which is managed by a department that is situated in the Energy Development Corporation Limited (EDCL), which is responsible for non-revenue generating infrastructure development (The World Bank, 2020b). Ethiopia on the other hand has a Directorate of Electrification within the Ministry of Water, Irrigation and Energy (Ethiopian Ministry of Water, Irrigation and Energy, 2019).

### 4.1.2 National Electricity Utility

A limited liability company, often with the government as the main or sole shareholder that is primarily engaged in the distribution of electricity. It is usually the sole buyer of electricity from the transmission company or directly from generation companies, has national coverage and is effectively a natural monopoly. In Kenya, Tanzania, Rwanda and Ethiopia, the national electricity utility is the electricity distributor. Uganda employs a different approach; through a concessional arrangement, the national electricity utility has leased its distribution assets to a private company who then distribute electricity. Unlike the other utilities, the Tanzanian utility is still vertically integrated; in addition to generation, it also performs the functions of electricity generation and transmission.

The national electricity utilities are characterized by a large customer base, with customer numbers as follows: Kenya—7 million, Ethiopia—2.7 million, Tanzania—2.3 million, Uganda—1.5 million and Rwanda—0.7 million (Source: Utility websites). In addition, most of their revenue (44%–56%) comes from less than 1% of customers who fall in the large commercial and industrial categories. While rural electrification is the remit of rural electrification agencies, where financially viable, national electricity utilities are usually responsible for investments in urban electrification. If necessary, customers must pay connection charges or additional monthly fees to contribute to investment costs that cannot be recovered through standard tariffs. To accelerate urban electrification, governments have also directly funded national electricity utilities.

### **4.1.3 Private Electricity Generation and Distribution Companies**

This category includes (1) private companies who develop, own and/or manage small, isolated electricity generation and distribution systems, and (2) private companies who manage publicly owned electricity grids under a concessional agreement (e.g., grid expansion projects implemented by the rural electrification agency); they purchase electricity in bulk from the national utility or transmission company for resale to consumers. Electricity customers on these privately owned or managed distribution grids range from as low as 50 (in micro grids) to tens of thousands (in distribution grid concessions). A 2020 mini grid market study commissioned by Sustainable Energy for All (Mini-Grids Partnership et al., 2020) estimates that Tanzania has 209 private isolated mini grids, while Uganda has 34, and Kenya has about 40 isolated mini grids (NewClimate Institute & EED Advisory, 2019). The private mini grid sector in Rwanda and Ethiopia is still in its early stages of development, Rwanda is estimated to have 66 private mini grids (although 59 of these are owned by one company and are micro grids below 4 kW) (Power Africa Off-grid Project, 2019a), while Ethiopia has about 6 (Power Africa Off-grid Project, 2019b).

### **4.1.4 Off-grid Solar Companies**

These are private companies marketing standalone solar PV solutions. These solutions range from solar lanterns to solar home systems kits (pre-designed systems sold as a complete package that include appliances) to component-based systems (custom designed to meet the consumers specific requirements). Special attention is paid to solar lanterns and solar home system kits (collectively referred to as off-grid solar products) because of the significant growth in global annual sales from less than 1 million units in 2010 to almost 40 million units in 2019 (Lighting Global et al., 2020).

## **4.2 What Shapes Firms in the Electrification Industry— The Industry Regime**

### **4.2.1 Core Capabilities**

To describe the knowledge and skills that reside in the electrification industry, we consider on-grid, mini grid and off-grid solar electrification technologies and implementation experience.

## On-Grid

We consider the scope of on-grid electrification as electricity distribution i.e., the final stage in the delivery of electricity from the transmission system to individual consumers. Distribution sub-stations lower the transmission voltage to medium voltage (1–33 kV). Primary distribution lines then carry this medium voltage power to distribution transformers. As a rule of thumb, multiplying the capacity of the primary distribution line by a factor of two gives an indication of how far it can be extended without negatively affecting voltage quality e.g., a 33 kV line should not be extended by more than 66 km from the distribution sub-station to the distribution transformer. Distribution transformers typically serve consumers within a 600 m radius via secondary distribution lines. Domestic and small commercial consumers are connected to secondary distribution lines through service drops, while large commercial and industrial consumers are connected directly to the primary distribution lines. The medium voltage network is considered the backbone for electricity distribution, and therefore for on-grid electrification.

On-grid electrification approaches can be categorized into: (1) grid densification—service drop installations and extending secondary distribution lines to connect unserved customers within reach of existing distribution transformers, (2) grid intensification—short extensions of the medium voltage network and installation of distribution transformers to connect housing clusters within 2.5 km of the existing medium voltage network, and (3) grid extension—longer medium voltage network extensions to connect settlements that are further away from the existing medium voltage network. In the countries considered, the average per connection costs for the different on-grid electrification approaches determined during the development of their electrification plans, are as follows: grid densification US\$ 160–747, grid intensification US\$ 600–1057, and grid extension US\$ 732–1273.

There has been experience with low-cost grid electrification technologies and approaches such as: (1) low-cost house wiring techniques—e.g., ready boards, which provide a standardized light and socket point for consumers who can afford to pay to wire their premises and incorporate a meter (Golumbeanu and Barnes, 2013), (2) single wire earth return technology (SWER)—suited to powering relatively small loads over long distances at low cost by cutting the quantity of conductors and insulators required and reducing labour requirements for line construction (Swiss Centre for Development Cooperation in Technology and Management, 1992), and (3) Shield Wire Systems—that run along existing high-voltage transmission lines and can supply household electricity to communities located within 20 km of the high-voltage corridor at a fraction of the cost of new substations or independent medium-voltage lines (ESMAP, 2017).

Having access to electricity at the normal tariffs does not confer on households the ability to afford to use it, which has necessitated the adoption of tariffs to support the social objectives of electrification. Gaunt outlines key specifications for a social tariff: (1) includes a subsidy to reduce the costs to customers to levels below a fully cost-reflective tariff, which may include the profits of a privatised utility. The subsidy will not be so large as to damage the economy and be derived from a source that can sustain it (e.g., a cross-subsidy), (2) promotes perceptions of fair pricing by incorporating geographic uniformity, (3) may restrict the terms of the service provided, such as by limiting the maximum current, (4) provides enough energy to make a difference in respect of the purpose for which it is intended, (5) enables beneficiaries to increase their power and energy consumption (when ready and able) without having to make a significant capital investment to access additional capacity (unlike off-grid solar products), (6) delivers the benefits to the targeted beneficiaries, with as little as possible leakage to those outside the group, (7) is structured a simple way to promote understanding and reduce the costs of implementing the tariff, and (8) is implemented in a way that does not reinforce long-term social dependency e.g., the tariff has a structure that provides flexibility for ‘managing’ it as conditions change (Gaunt, 2005). Lifeline tariffs are a good example of a social tariff. They are targeted subsidies based on the consumption level of households (i.e., subsidized rates based for a first block of consumption enough to cover basic needs). The domestic electricity tariffs for the countries considered, assuming a monthly consumption of 30kWh, are as follows: Ethiopia—US\$ 0.02/kWh, Kenya—US\$ 0.2/kWh, Rwanda—US\$ 0.23/kWh, Tanzania—US\$ 0.07/kWh, and Uganda—US\$ 0.2/kWh (The World Bank, 2017a).

Area coverage, a blanket electrification strategy based on connecting and supplying all potential customers, is also appropriate for social electrification and complements a social tariff. Restricting grid access to those customers who can make the greatest economic or socio-economic use of electricity, or who can afford connections, denies the benefit of a social tariff to the households most in need of the support (Gaunt, 2005).

### **Mini Grids**

Mini grids are generation and distribution systems that can provide electricity to a few customers in a remote settlement, or hundreds of thousands of customers in a town or city. They can be fully isolated from the main grid or connected to it but able to isolate themselves from the grid. Mini grids interconnected to the main grid can e.g., purchase power in bulk from the main grid to distribute and retail to customers on the mini grid, generate power to supply their customers and sell

excess power to the main grid via a power purchase agreement or net-metering arrangement.

Nearly all current centralized electricity grid systems started with isolated mini grids, which gradually interconnected. These first-generation mini grids were key to the early development and industrialization of most modern economies. A second generation of mini grids is widespread in many low-income countries today. These systems are typically small and isolated, powered by diesel or hydro, and built by local communities or entrepreneurs to provide access to electricity to households, primarily in rural areas that have not yet been reached by the main grid. Mini grid developers are now leveraging transformative technologies and economic trends to build third-generation mini grids with the potential to provide high-quality, affordable electricity at scale. A typical third-generation mini grid is an alternating current (AC) mini grid that consists of a solar-hybrid generation system that includes solar panels, batteries, charge controllers, inverters, and diesel backup generators and is designed to interconnect with the main grid. These mini grids typically use smart, remotely controlled electricity meters that allow customers to prepay for their electricity, and deploy remote monitoring systems to manage the status of the system in real time from a distance (ESMAP, 2019). Third generation mini grid developers are also stimulating electricity demand by implementing or facilitating activities that provide their customers with access to and financing for income generating appliances. Some directly invest in equipment, that uses the electricity they generate, to provide services such as refrigeration, water purification and milling for a fee (Absolute Energy, 2021).

Mini grid capital costs have been declining and are expected to continue a downward trend through 2030. The costs of key mini grid components, such as solar panels, inverters, batteries, and smart meters, have decreased by 62–85% because of innovations and economies of scale in utility-scale solar projects, the booming rooftop solar industry, and the growing electric vehicle market. This is expected to bring down the capital costs from US\$ 3900/kW in 2018, to below US\$ 3000/kW by 2030 (ESMAP, 2019). In the countries considered, the cost for establishing mini grids, as determined during the development of their national electrification plans, ranges from US\$ 630–1712 per connection.

ESMAP modelling, indicates that a well-designed solar-battery-diesel hybrid mini grid serving more than 1500 people has a levelized cost of energy (LCOE) of about US\$ 0.55/kWh when it serves household customers, giving it a load factor of about 22%. As the cost of efficient income-generating machines and equipment decreases and developers increase demand for income-generating uses of electricity during the daytime, mini grids can increase their load factor to more

than 40%. An 80% load factor can be achieved by inclusion of a water pump with storage tank and an anchor load, such as a telecom tower. As a result of declining capital costs and increased load factor, the per kWh cost of mini grid electricity is expected to decrease to US\$ 0.20/kWh by 2030.

While most mini grids installed are AC, solar mini grids can also be configured to be direct current (DC) mini grids (often referred to as micro-grids) that integrate DC electricity supply with DC distribution and DC electrical appliances. DC micro-grids possess significant energy efficiency and cost advantages over AC distribution systems because of the lack of a need for energy conversion (i.e., DC-AC inverters), and are well suited to rural communities with low power demands. Where future grid interconnection is unlikely to be technically or financially feasible, DC micro-grid designs can be far more optimal due to lower capital costs and greater reliability, particularly in settings where settlements are more compact and long-distance energy transmission or higher energy business uses are not a factor (Mini-Grids Partnership et al., 2020). In Tanzania, for example, Devery has been implementing DC micro-grids that are based on interconnecting small modular generation units, which are added as, when, and where needed to meet growing electricity demand and new customers. This approach enables the developer to expand the coverage and capacity of the micro-grid organically and affordably e.g., by developing multiple clusters of micro-grids over time as opposed to having to develop a single large mini grid at once.

### Off-grid Solar

Price reduction in solar PV modules and balance of system components, as well as technological advancements in LED lighting, Li-Ion battery technology and efficient appliances, enabled the development of a new generation of high-performance low cost off-grid solar solutions i.e., single light solar lanterns and multi-light solar systems (<10 Wp) and solar system kits (10–350Wp). A database of over 190 quality verified products of this type can be viewed at <https://data.verasol.org/>. This new range of solar lighting products provide a cost competitive alternative to kerosene for lighting, while pre-designed solar system kits (sold with lights and other appliances i.e., phone chargers, radios, TVs, fans and fridges) address challenges related to appropriate sizing of systems and installation (historically responsible for high solar PV system failure rates and associated with the component-based approach to selling solar PV systems (Muchunku et al., 2018)).

In Eastern Africa, off-grid solar companies also leveraged the development and uptake of mobile money transfer systems to facilitate consumer finance models by bringing down the cost and complexity of debt recovery and making it



possible to centrally manage a large pool of dispersed consumers. Mobile money makes it easier for consumers to make repayments for their systems wherever they can access a phone signal and make smaller payments more frequently. Furthermore, these electronic payments are linked to remote monitoring and control systems, enabling providers to monitor recovery rates in real time and remotely disable systems of defaulting or delinquent customers (Muchunku et al., 2018).

The most common business models employed by off-grid solar companies are (1) a retail model—cash sales for off-grid solar products up to 3Wp, in the US\$ 3–30 price range, and (2) a Pay-As-You-Go (PAYGo) model—a consumer financing model for products in 3–100Wp range, with a cash price value of US\$ 30–1000. The PAYGo model is based on a 13–19% down payment and periodic repayments (often daily) over a 12–36-month period (Lighting Global et al., 2020).

To a limited extent, a fee-for-service model has also been deployed for off-grid solar systems. The fee-for-service model is similar to the grid or mini grid model since customers only pay for the electricity services provided and ownership of the system is never transferred. In solar system fee-for-service models, electricity services are provided through standalone systems as opposed to an electricity distribution network. The fee-for-service model is typically based on a one-off joining fee and a monthly service fee for electricity services provided. For large off-grid solar systems this approach is significantly more affordable for customers than models where they have to pay for ownership as well as future maintenance and replacement costs. In its most basic form, it can be also applied as a rental model for solar lanterns or rechargeable batteries, where customers pay a recharging or usage fee. In 1999, the South African government introduced the fee-for-service is model for off-grid electrification i.e., to provide 50Wp solar systems to households more than 2 km from the distribution grid and in areas outside 3-year grid electrification plans (Energy Department: Republic of South Africa, 2012). Private companies who have implemented this model in Eastern Africa include Nuru Energy in Rwanda and FRES in Uganda.

IEA's Africa Energy Outlook forecasts that as income levels increase across sub-Saharan Africa, households will increasingly own appliances such as phones, televisions, refrigerators, washing machines and air conditioners. In rural areas the largest increases in appliance ownerships are expected to be for televisions and refrigerators. In the Africa Case policy scenario, television ownership is expected to increase from 0.2 units per household in 2018, to 0.8 units per household in 2040, while refrigerator ownership increases from 0.1 units per household to 0.7 units per household. Increases in ownership of air conditioners and washing machines are expected to be modest; in the range of 0.1 units per household

in 2040 (International Energy Agency, 2019). Significant improvements in the energy efficiency of DC household appliances and the bundling of these with solar home system sales now enables off-grid customers to use appliances previously reserved for grid-connected AC customers (Lighting Global et al., 2020). Today's off-grid solar systems can technically provide the energy services that most rural households are expected to require by 2040.

Most of the off-grid TVs currently sold are DC powered and are sold via PAYGo as part of a solar system. They are mostly in the 15–32 inch size range and the US\$ 53–300 price range (Verasol, 2021). In terms of global sales, the East African market represents the largest regional market for off-grid TV sales with 2020 sales figures as follows: Kenya—259,691, Uganda—15,684, Tanzania—30,709, Ethiopia—602, and Rwanda—10,414 (Global Off-Grid Lighting Association et al., 2020, 2021). Refrigeration units specifically designed for off-grid applications still have an extremely low penetration rate. In Eastern Africa, GOGLA's 2020 reports indicate sales of 2722 refrigeration units in Kenya, 1100 in Uganda, and 38 in Tanzania. Most refrigeration units are sold through PAYGO and bundled with a dedicated power system. These units, which range from 30–240 L in capacity, retail at US\$ 160–1050 excluding the power system (Verasol, 2021). The most common units are medium sized refrigerators i.e., 51–100 L units with one or more fresh food compartments but no freezer compartment.

Taking into consideration only sales of quality verified off-grid solar products (Verasol, 2021), 2020 annual unit sales were estimated as follows: Kenya—1.9 million, Ethiopia—600,000, Tanzania—290,000, Uganda—280,000 and Rwanda—150,000 (Global Off-Grid Lighting Association et al., 2020, 2021). This widespread adoption of off-grid solar systems is indicative of a change in taste that is challenging an informal constraint i.e., that grid-based electricity is the only form of electricity acceptable to consumers, and that solar PV systems should provide a level of service identical to that provided by a grid connection.

#### **4.2.2 Industry Mindset**

We postulate that the following notions shape the mindset of the electrification industry:

1. *In addition to meeting the economic and socio-economic objectives of electrification, governments and national electricity utilities also need to meet the social objectives of electrification.*

Using the South African experience, Gaunt demonstrates that electrification has been implemented to meet three very different objectives: initially economic (the first electricity utilities were the municipalities in the main towns

and private companies supplying business, mining and related industries and for 80 years (from 1900) economics drove electrification), later socio-economic (spurred by political pressures in the 1970's and 80's, the electricity utility extended subsidized supplies to farms and rural service centres to keep farmers in business and support the development of rural areas), and recently social (i.e., due to religious obligations to help the needy, philosophical principles of giving equal consideration to the interests of all, and political or pragmatic reasons to help the poor). Although different solutions are needed to reach different objectives, the change was not immediately evident in many cases, because all the existing processes, networks, tariffs, and regulations had developed around concepts of electrification driven by economic objectives (Gaunt, 2005).

The viability assessments of economic electrification projects are based on financial analysis e.g., financial models of net present value or internal rate of return. Revenues based on realistic estimates of the customers' demand and consumption recover all costs. Only viable projects are implemented. If necessary, customers must pay connection charges or additional monthly rental to contribute to investment costs that cannot be recovered through standard tariffs. The viability of electrification for socio-economic reasons is based on economic analysis that attempts to quantify how electrification supports development by contributing to improved health, education, and other services that eventually bring customers into the formal economy. However, economic and financial analysis are inappropriate for assessing the benefits of social electrification because the development impacts are long term, because it is difficult to express the benefits in economic values, and because of the tendency to understate welfare and multiplier benefits.

Social responsibilities have the potential to obscure or confuse the utilities' more obvious goals of delivering electricity efficiently and profitably. They also make more complex the role of the electricity regulators, who need to interpret conflicting aspects of government policy with regard to economic and social development.

2. *Electricity tariffs should be geographically uniform to promote perceptions of fair pricing.*

Private sector mini grids are still considered experimental due the cost reflective nature of their tariffs; they charge significantly higher electricity tariffs (4–20 times more than national grid tariffs), while political preference is for a national uniform tariff. However, private mini grid developers argue that consumers are able and willing to pay these high tariffs because they get a better

service at a lower price than the alternatives that are available to them (i.e., kerosene, diesel, and phone charging services) (Pedersen & Nygaard, 2018).

3. *Solar home systems are meant to be owned by the user.*

This results from solar home system business models being historically and predominantly based on selling products (i.e., transferring ownership) rather than selling electricity services.

4. *The solar home system is not socio-politically considered as a complete or final electrification solution for households, and the same applies to mini grids that do not provide a level of service equivalent to the national grid.*

This can be illustrated by the Multi-Tier Framework (MTF) for measuring access to electricity (Bhatia and Angelou, 2016), which uses five successive tiers categorized on the basis of their electricity supply attributes e.g., the ability to use certain appliances (or access certain energy service). Other supply attributes that are considered are the power/energy capacity, number of hours per day electricity is available and aspects such as reliability, quality, affordability, legality and health and safety, which mostly apply to higher electricity access tiers. A complete and final electrification solution is considered as one that allows a household to seamlessly graduate from the lowest to highest electricity access tiers when ready. While solar home systems can technically provide tier 0–5 levels of electricity access, affordability constraints restrict them to mostly providing tier 0–2 levels of access i.e., providing general lighting, phone charging, television, and air circulation (fan) if needed.

### 4.2.3 Values, Identity and Mission

Rural electrification agencies see themselves as responsible for facilitating equitable and universal provision of electricity for social and economic development in rural areas. Following changes in energy legislation in recent years, their mandate in some countries (e.g., Kenya and Tanzania) has been extended to include provision of other modern energy services and promoting the use of renewable energy technologies. However, provision of electricity in rural areas is still their focus.

Following the corporatization or commercialization of national electricity utilities, delivering shareholder value (where private investors have a stake), or delivering services commercially (where government is the main shareholder) is a key part of their mission. These utilities strive to deliver electricity services sustainably, while ensuring the quality and reliability of supply.

Both off-grid solar companies and private mini grid developers view themselves as social enterprises driven by a social mission to delivery electricity access in a financially sustainable way through advanced technological components and systems, and business models. The incentives of these companies are designed such that more impact directly correlates to more profit.

There was a strongly held belief amongst off-grid solar companies that the lower cost of energy access via off-grid solar products, and economies of scale were sufficient to enable access for all. Their position therefore was that public and donor funding should solely be directed towards activities that developed a sustainable and competitive open market e.g., subsidizing industry wide needs such as the development of quality standards, mass consumer education campaigns, and activities that provide consumers with opportunities to see the benefits of off-grid solar (Global Off-Grid Lighting Association, 2015). However, more recently, the prevailing view of these companies is that end-user subsidies will be needed to reach the poorest households with clean energy access. Nevertheless, they emphasize that due to the potential risk of negative market distortion, which could instead slow-down energy access, end-user subsidies need to be carefully designed and implemented to ensure there is no competition between the subsidized and commercial market (Global Off-Grid Lighting Association & Get.invest, 2021).

Private mini grid developers also consider themselves as niche actors working to challenge the incumbent electrification regime to develop and grow the private mini grid niche. The electrification regime is currently based on grid extension and mini grids for large towns, which are operated by the national electricity utility. The work these niche actors are undertaking includes: (1) research to generate data from pilot projects to build a business case for mini grids to attract investment, (2) creating a normative and moral narrative about the private mini grid model (e.g., challenging the national uniform tariff norm by demonstrating that private mini grids provide better service at a lower price than the inferior alternatives available to those without access), and (3) improving the policy framework for private sector mini grids by establishing the parameters of future institutional structures and practices e.g., tariff models, grid codes, grid interconnection and cross-subsidy models for private mini grids (Pedersen & Nygaard, 2018).

#### **4.2.4 Regulations, Laws, and Standards**

##### **Electricity Licensing Laws or Regulations**

Licensing regulations specify the license and permit application processes, fees, requirements, obligations and conditions for license or permit revocation for the following: (1) generation licensees—entities authorized to operate a generating station and connect to a distribution or transmission network, (2) transmission licensees—entities authorized to operate a transmission network and connect its network to another transmission or distribution network, (3) distribution

licensees—entities authorized to operate a distribution system, and (4) supply licensees—entities authorized to supply electricity to consumers through a series of commercial activities i.e., procuring the energy from other licensees, inspection of premises, metering, selling, billing and collecting revenue.

Rwanda's electricity law additionally provides for concession licenses—to be granted by the Minister in charge of electricity, and rural electrification licenses—a simplified license to expedite licensing for rural electrification projects for those operating in rural areas ("Law No.21/2011 Governing Electricity in Rwanda", 2011). Tanzania's legislation provides for licensing exemptions for generation, and off-grid distribution and supply activities in rural areas where the capacity is below 1 MW ("The Electricity Act of 2008, Tanzania", 2008).

Licenses contain particulars or conditions for e.g., provisions for bulk and retail tariffs or charges for electrical energy and capacity for different types of licensees and classes of consumers, provisions for the determination of charges for use of the transmission and distribution network services, the term of the licence, the maximum capacity of supply of the undertaking and the area of supply of the undertaking. Licensing regulations specify the factors considered in the granting of a license, which include: the economic and energy policies in place, the economic and financial benefits to the country or area of the undertaking, the proposed tariff offered, potential adverse effects to the contractual rights, and obligations of an existing licensee.

Electricity laws also require that all agreements relating to the sale of electrical energy and the provision of transmission and distribution network services between and among licensees, and between licensees and consumers, be approved by the electricity regulator before execution. The regulator also prescribes the principles for the tariff structure and the terms for the supply of electricity to consumers and is responsible for the review and approval of retail tariffs (which could be on a cyclical or need basis).

Licensing and tariff design principles have effectively legitimized and entrenched distribution utility monopolies and uniform national tariffs. Licensing regulations favour incumbent utilities since a distribution and supply license cannot be awarded for areas that have already been licensed out. Monopolies, however, make some regulations impossible to enforce e.g., revocation of licenses. In addition, since incumbent utilities have the widest network coverage nationally, the tariffs they charge become a national benchmark, which makes it politically inexpedient for regulators to approve higher tariffs for smaller distribution and supply licensees, even when they are justified.

### **Rural Electrification Fund**

Rural electrification funds are typically established through primary legislation with the objective of accelerating the development of electricity infrastructure to provide electricity services to improve economic and social development in rural areas. The legislation prescribes where the monies for the fund will be sourced e.g., electricity sales levy, and other monies appropriated by parliament, loans and grants from other governments and international finance institutions, and grants from non-governmental organizations. The fund is usually administered by the rural electrification agency.

Rwanda adopted a different approach to raising funds for electrification. The Ministers of Finance and Energy and senior development partners developed an energy sector-wide approach (SWAp) to help achieve its target of increasing electricity access. Under the SWAp approach, governments, donors, and other stakeholders join within a particular sector to coordinate sector specific policy, funding, and goals. Under government leadership, the approach involves movement over time toward common goals and coordination for funding and procurement. The SWAp is anchored in an investment prospectus for extending electricity access, which is used to raise co-finance from development partners to address the investment funding gap (Sanghvi and Gerritsen, 2012). In addition to this, the 2011 Law Governing Electricity in Rwanda provides for a Universal Access Fund to optimize access to electricity. It is based on contributions collected from dealers in electricity, as determined by Presidential Order (“Law No.21/2011 Governing Electricity in Rwanda”, 2011).

### **Net Metering**

Some electricity laws provide for net metering where a consumer who owns a renewable energy generator located in the area of supply of a distribution or supply licensee may enter into an agreement to operate a net metering system i.e., a system that measures the amount of electrical energy that is supplied by the distribution or supply licensee to the consumer who owns the renewable energy generator and vice versa (“The Energy Act No.1 of 2019, Kenya”, 2019). In the countries considered for this study, Kenya and Tanzania have legislation that provides for this. Uganda, Rwanda, and Ethiopia do not currently have net metering legislation, but there are indications of government interest. Under its Decentralized Renewables Development Program (African Development Bank, 2017) Uganda has plans to pilot net metering systems on public buildings and draft legislation and standards to scale-up net metering. Rwanda has piloted net metering, while Ethiopia is considering it as regulatory environment improvement for

mini grid development i.e., as a strategy for integration in mini grids are interconnected with the main grid (Ethiopian Ministry of Water, Irrigation and Energy, 2019).

### **Distribution Grid Code**

The distribution code is defined as the requirements that users (i.e., persons or entities), connected to or making use of the electricity distribution system, must meet to ensure safe, secure, reliable and efficient of the system. Users include generation licensees, distribution licensees, and consumers—a person or entity obtaining end-use electricity supply from a licensee. Since the grid code applies to licensees, it is used in conjunction with the electricity licensing regulations.

The distribution code specifies: the technical and design criteria and procedures for the planning and development of the distribution system, the minimum standards for the methods of connection to the distribution system, operational components of the distribution system (e.g., demand management, interruptions, incident reporting), safety and system emergencies, the technical and operational criteria for providing metering services, and the technical and operational performance standards for supply quality, power quality and distribution energy losses, and the indicators used to measure these.

Unlike distribution systems supplying economic customers, the costs of under-design and under-capacity for electrification systems implemented for social objectives are low. This enables conservative load forecasting, which allows for leaner, more flexible design specifications and for the adoption of low-cost solutions e.g., (1) greater application of single-phase instead of the traditional three-phase distribution at medium and low voltage, (2) adoption of new technologies in line design and feeder conductor selection, (3) broad application of pre-payment metering, and (4) revised industry standards and implementation procedures (Bernard et al., 2008). Since low-cost electrification technologies and approaches are in line with the government's objectives of increasing electricity access, the distribution code, which is typically developed and enforced by the electricity regulator, has not been a significant barrier to adoption. In Tanzania, for example, electricity legislation allows the regulator to prescribe different technical quality of supply and reporting standards for licensee activities in rural areas, where such standards can reduce the cost and promote investment in rural electrification ("The Electricity Act of 2008, Tanzania", 2008).

### **Electricity Supply Reliability and Quality**

Electricity supply reliability and quality are key attributes for defining and measuring energy access. Reliability is measured by the frequency and length of



unscheduled outages/interruptions, while quality relates to voltage and frequency fluctuations. The distribution code specifies thresholds for the quality of supply that distribution utilities should comply with. With regard to reliability of supply, utilities are required to measure and report on their performance using a set of prescribed indicators. In Tanzania, distribution utilities are required to make public their targets for reliability of supply for the following year, disaggregated into targets for rural, urban and industrial consumers (Energy and Water Utilities Regulatory Authority, 2017). Requirements for reliability of supply are rarely specified in the distribution code or actively enforced. Kenya does prescribe performance standards for unscheduled interruptions and voltage level tolerance values. Its distribution code disaggregates consumers into urban and rural, with lower performance requirements prescribed for rural consumers (The Energy and Petroleum Regulatory Commission, 2017).

Two indicators commonly used to monitor grid reliability are, (1) System Average Interruption Frequency Index (SAIFI)—a measure of the average number of outages experienced by a customer on the grid, typically measured over a year, and provided for a city, region, or entire national grid in units of outages per year per customer, and (2) System Average Interruption Duration Index (SAIDI)—a measure of the average time of outages experienced by a customer on the grid, typically measured over a year, and provided in units of minutes or hours of outages per year per customer. The tolerances prescribed in Kenya for unscheduled interruptions for urban and rural customers respectively are SAIFI—3 and 6 outages per year, and SAIDI—2.5 and 7 h per year. Grid reliability data for Kenya collected as part of the World Bank's Doing Business (The World Bank, 2021a) and Enterprise surveys (2021b) gives SAIFI and SAIDI values of 6.9 outages and 12 h from the 2019 Doing Business surveys, and SAIFI and SAIDI values of 45.6 outages and 264.5 h from the 2018 Enterprise surveys.

By comparing reliability data across 109 low- and middle-income countries, Taneja demonstrated that utilities on average reported 15% of the outage durations that customers reported (Taneja, 2017). This conclusion was based on comparing data from the Doing Business surveys (which is reported by utilities) with information from the Enterprise surveys (which is reported by consumers). Before electricity reliability can be improved, it needs to be accurately measured. However, many utilities in low- and middle-income countries have limited instrumentation for measuring electricity reliability events. While there may be sensors for monitoring the condition of transmission lines, distribution lines often go unmonitored, and outages go unreported until unhappy customers contact the utility directly. While this can be addressed by smart meters capable of automatic notification of electricity outages, due to the technical capacity and

excessive costs of meters, installation, and the analytic packages required, many utilities in the developing world have few, if any, plans to install such meters. In their absence measuring the reliability of electric grids is difficult (Taneja, 2017).

The foremost cause of electricity outages in Nairobi, Kenya is fuses. These faults occur when there is a local overload on a transformer, causing one phase to blow its fuse and lose power until the fuse is replaced. Proactive strategies to prevent such outages include replacing undersized transformers and rebalancing of phases i.e., moving customers from phases with heavier loads to phases with lighter loads. Though phases were likely initially balanced, unequal evolution in customer demand is likely to create imbalances over time. Faults with wider scope were found have a larger impact on the SAIFI and SAIDI indicators than those with the highest frequency. These are: (1) feeder faults—large scale outages resulting from maintenance activities (including scheduled outages) and other major events, and (2) phase across feeder faults—medium voltage conductor faults that can affect customers on the same phase of all transformers on the feeder. These can be addressed with better maintenance scheduling strategies and accelerating response to unexpected large faults. Beyond the customer service benefits of fewer and shorter outages, a key motivation for reducing outages is collecting revenue from additional electricity sales (Taneja, 2017).

A case study of a rural distribution grid in Unguja, Tanzania illustrates that when electricity is supplied by a capacity constrained grid to a resource constrained population, the quality of service can vary both spatially and temporally (Jacome et al., 2019). Using measurements from sensors at increasing distance from transformers revealed periods in which voltage measurements were well below the standard of 10% of the nominal voltage, which can lead to damaged appliances. Notably this was predominant for connections outside the 600 m recommended connection radius for the transformer. The study showed that voltage quality was more of a problem for respondents who owned high tier appliances (e.g., fridges, freezers, or blenders), than for those who only owned low-tier appliances (e.g., lights, television, or irons), which are common and less sensitive to voltage fluctuations.

The Multi-Tier Framework (MTF) for measuring access to household electricity supply sets thresholds for electricity reliability and quality. The thresholds for reliability are based on the SAIFI and SAIDI indicators and are more than 728 outages per year for tiers 0–3, 208–728 outages per year for tier 4, and less than 156 outages per year and a SAIDI of less than 312 h for tier 5. The quality requirement is that voltage is within the parameters specified by the distribution code and that voltage problems do not prevent the use of desired appliances.

The World Bank has implemented surveys on energy access using the MTF in Kenya, Rwanda and Ethiopia (The World Bank, 2020c). In Kenya 48.8% of grid-connected households experienced outages between 3–14 times a week (SAIFI of 156–728 outages), and 17.5% faced voltage issues that resulted in appliance damage (The World Bank, 2019). In Ethiopia 57.6% of grid-connected households experienced 4–14 outages a week (SAIFI of 208–728 outages), and 15.8% of households faced voltage issues that led to appliance damage (The World Bank, 2018a). In Rwanda 91.7% of grid-connected households experience more than 4 electricity disruptions a week (SAIFI of >208 outages). Nationwide, 20.9% of grid-connected households face voltage issues such as low or fluctuating voltage (The World Bank, 2018b).

### Mini Grid Regulations

Tanzania is considered a regional leader in mini grid development (Odarno et al., 2017). In 2008, Tanzania adopted a ground-breaking mini grid policy and regulatory framework to encourage investment in the sector, which has been reviewed and updated several times, most recently in 2020 (Energy and Water Utilities Regulatory Authority, 2020). A possible key success factor is the formal establishment, through the regulations, of a working group on small power development comprising of representatives of key public and private sector actors and stakeholders in the mini grid sector. The role of the working group includes advising the regulator on modifications or general improvement of the rules and guidelines related to small power development.

Tanzania's mini grid legislation defines a strategic area as an existing publicly owned distribution network operating at 33 kV or below with at least 10,000 customers. Small power projects, defined as electricity generating projects with a capacity of 100 kW–10 MW, can only be developed in strategic areas if: (1) they improve the voltage profile, (2) reduce the distribution network operator's system losses by at least 10%, or (3) they are being served using diesel or furnace oil engines. Small power projects can be developed through unsolicited proposals i.e., an application to a distribution network operator for a letter of intent—a statement of intent from a distribution network operator to connect and purchase power that a small power project developer offers to produce. A distribution network operator may also invite developers to submit bids to supply identified strategic areas. The regulations prescribe a 20-year standardized power purchase agreement based on technology specific tariffs pre-approved by the regulatory authority.

Very small power projects are defined as electricity generating projects with a capacity of <15 kW at a single site selling power to at least 30 retail customers, or a with a capacity of 15–100 kW either selling power at wholesale to a public

distribution network operator or retailing it to end customers. These types of projects shall only be developed in remote areas certified by the Ministry responsible for electricity.

Electricity generating, distribution or supply activities for projects with a capacity below 1 MW are exempt from licensing. However, developers of these projects are required to apply for and be issued with a certificate of registration from the regulatory authority before commencement of commercial operations. Mini grid operators are granted exclusive rights to distribute electricity in the area of service specified in the license or registration certificate issued by the regulator.

If a public distribution network operator or the rural electrification agency intends to connect a mini grid to the national grid, Tanzania's legislation makes provisions for the small power producer serving the mini grid, and the small power distributor retailing electricity to customers on the mini grid. The small power producer selling electricity to the mini grid may apply to the regulator for the right to sell electricity to the public distribution network operator, and the small power distributor may apply to purchase electricity from the national grid (i.e., through the public distribution network operator) under a bulk supply tariff, for resale to the customers on the mini grid. Alternatively, the small power producer and small power distributor may apply for asset compensation from the public distribution network operator or the rural electrification agency. The valuation of the distribution assets is dependent on their conformity to prescribed standards and the compatibility of the meters used with the public distribution network operator's billing and collection system.

Tanzania's legislation also prescribes specific tariff design principles for small power producers that retail the electricity they generate, and small power distributors, who purchase electricity in bulk for resale. The tariff design principles are based on full-cost recovery and a reasonable return on equity, and tariffs require approval by the regulator before the sale or offer of sale of electricity to customers. In addition, the community to be supplied should be informed about any tariff application due to be submitted to the regulator for approval. To calculate a reasonable return, the assets considered by the regulator exclude grants received from the rural electrification agency, government, or donors. Retail tariffs may include on-bill financing for e.g., connection charges, internal wiring, and end-use equipment for productive use.

Bilateral power purchase agreements for the sale of electricity to eligible customers are exempt from tariff approval. Eligible customers are entities authorized by the regulator to enter into contract for the purchase of electricity directly from an entity licensed to supply electricity.

Mini grid regulations in Kenya, which are under development, are more onerous, they propose a three-step process comprising of: (1) submission of an expression of interest (EOI) to the Ministry for exclusive site reservation and allocation, (2) an application for tariff approval from the regulator, and (3) an application to operate the generation and distribution infrastructure (Energy & Petroleum Regulatory Authority, 2021). These requirements are for all mini grids with a capacity of up to 1 MW i.e., there is no provision for exemptions or simpler requirements for low-capacity mini grids (e.g., <100 kW), as is the case in Tanzania.

To submit and EOI for site reservation private mini grid developers already have to had undertaken a feasibility study, engaged with the local community, received a letter of no objection from the local government and developed an indicative tariff. Subsequent to the EOI being approved, the developer then has to fulfil additional and more detailed requirements for tariff approval (e.g., full feasibility study, environmental authority approval, proof of land ownership or land lease agreement for the generating plant, way leave agreements for the distribution network and a community endorsement contract), and for licensing (e.g., local government planning approvals, evidence of a physical office or dedicated on-site staff, and publishing of a public notice of the license application to enable persons who may be affected to lodge an objection with the regulator). Kenya's proposed regulations also have provisions for the arrival of the national grid and its interconnection with the mini grid, which are intended to enable private developers to (1) continue generating income from the generation or distribution and supply of electricity, or (2) to sell off their assets to recover their investment.

In contrast, for the development of public mini grids for which the national uniform tariff shall apply, the implementing agency is only required to submit a notification to the regulator, which comprises of: (1) a feasibility study, (2) environmental authority approval, (3) an agreement between the implementing agency and the agency that will be responsible for operation and management of the mini grid where applicable (it is common practice for the rural electrification agency to develop mini grids and then transfer them to a distribution and supply licensee for operation and maintenance), and (4) evidence of dissemination of a public notice of the intention to develop the mini grid.

Uganda and Rwanda's mini grid regulations are similar to Kenya's, but they have simplified requirements i.e., requiring only application for registration for mini grids with a capacity below 500 kW and 50 kW in Uganda and Rwanda respectively (Electricity Regulatory Authority, 2020) (Rwanda Utilities Regulatory Authority, 2019). In Ethiopia, while developers or mini grids with a capacity of up to 50 kW also require a license, they are allowed to negotiate tariffs directly with the community and enter into a contractual agreement with customers, subject to endorsement from the local authority. They are exempted from a tariff application and review by the regulator (Ethiopia Energy Authority, 2020).

Rwanda and Kenya explicitly provide for DC mini grids, while Uganda and Ethiopia's power quality specifications only allows for AC mini grids. However, in all the countries considered, DC mini grid developers have no recourse when the main grid arrives.

There is information asymmetry between public actors (i.e., rural electrification agencies and national electricity utilities) and private mini grid developers with regard to which sites are not considered for grid extension or mini grids, in the short to medium term, in the national electrification plans. The result of this is that mini grid developers can, and do, spend a lot of resources in identification of potential sites and the preparatory work to develop these, only to be informed that the sites are already considered for electrification by the rural electrification agency or national electricity utility.

To a significant extent current mini grid regulations lean more toward being tokens to appease private mini grid developers rather than an acknowledgement of the value they can add and a deliberate attempt to fully integrate them into national electrification planning and implementation. The regulations require a significant level of effort required from private mini grid developers to identify and develop a site. In contrast, due to government support, rural electrification agencies and national electricity utilities do not have to put in anywhere near the same level of effort to identify and develop mini grid sites. Considering the remoteness, low population density and low economic activity in most of the available sites, this effort is not concomitant with the potential return on investment for mini grid developers.

Pedersen et al. point out that in Kenya, some private mini grid developers are deliberately avoiding the time-consuming and bureaucratic process of obtaining licences and negotiating tariffs with the regulator. Instead, they have established a verbal agreement that they can run their projects as pilots to avoid the bureaucratic process. They focus on, (1) improving operations and services to put themselves in a position to a first choice for potential investors, and (2) developing collaborative relationships with the national utility to position themselves to provide contractor services and supply technology. Other developers are adopting a more head on approach, initiating bilateral and multilateral meetings with the regulator, the national electricity utility and the rural electrification authority to agree on how the proposed policy and regulations can be implemented effectively in practice (Pedersen & Nygaard, 2018).

### **Off-grid Solar Quality Standards**

In a review of solar home system projects supported by the World Bank and the Global Environmental Facility from 1993–2000, Martinot et al. state that the market for solar home systems has historically been plagued by challenges of poor quality products, poor installation and maintenance, and systems being oversold

(i.e., through marketing claims that raise false expectations about what the systems can deliver) (Martinot et al., 2001). Funded projects can prescribe and enforce the standards within the scope of their project. However, after project completion, this task should transition to government by supporting the development and implementation of broader national compliance frameworks to enforce the standards.

The Lighting Africa program, developed by the International Finance Corporation and the World Bank and launched in 2009, adopted this approach (World Bank & IFC, 2021). Lighting Africa is a regional market development program with the objective of catalysing markets to deliver affordable, high-quality off-grid lighting and energy products. To protect consumers from poor-quality products and promote consumer confidence, Lighting Africa developed a series of quality standards and test methods for pico-PV lanterns and subsequently for solar home system kits with a peak solar PV capacity up to 350Wp. To meet the standards, products were tested against a baseline level of quality, durability, and truth-in-advertising. The market development program then exclusively worked with products that met the prescribed minimum standards, which resulted in a virtuous cycle of positive consumer experiences leading to increasing consumer confidence and increased adoption. These positive consumer experiences have also contributed to increasing government confidence in off-grid solar products and subsequently resulted in them ratifying the use of public funding to support the use of off-grid solar as an electrification approach.

As part of the transition to adoption and enforcement of these standards by governments, these program standards were adopted the International Electrotechnical Commission (IEC), which paved the way for their adoption by governments as national standards (Verasol, 2020). These standards have recently been adopted by Kenya, Tanzania, Uganda, Rwanda, and Ethiopia as mandatory national standards, which will be enforced by restricting the importation of off-grid solar products to only those that can demonstrate that they meet the adopted standards.

### **4.3 What Influences Firms in the Electrification Industry—External Environments**

#### **4.3.1 Socio-Political Environment**

##### **National Electrification Plans and Strategies**

Largely driven by commitments to deliver on the sustainable development goals, most of the governments in the countries considered for this study have recently developed or updated their national electrification plans and strategies with a

view to achieving universal electricity access by 2030. These strategies incorporate both on-grid and off-grid approaches, with private sector envisioned as having a key role in delivering electricity access through off-grid approaches.

Electrification planning typically uses geospatial data on e.g., electricity transmission and distribution infrastructure, population settlements (e.g., administrative cities, towns and villages, clustered housing structures, and trading centres), and social and administrative infrastructure (e.g., educational institutions, public water supply, health facilities and police stations), to determine which on-grid or off-grid electrification approach is most technically and economically suitable to deliver access. Using this geospatial information, integrated electrification planning defines the grid expansion boundary which demarcates where off-grid projects are developed, prescribing mini grids for settlements with sufficiently high housing density and off-grid solar for those without.

The foundation of an electrification plan is based on, (1) the existing medium voltage distribution network coverage, and how it is projected to grow over the planning period, and (2) the unit of electrification—the minimum size of the population settlement considered for grid extension or mini grid projects.

Countries with low medium voltage network coverage usually have unelectrified population settlements that are large in both size and number. These countries have a greater need for grid extension or mini grids to deliver electricity access to these large population settlements. In addition, where it will take time to increase the medium voltage network coverage, off-grid approaches are expected to have a long-term role i.e., the duration before mini grids are interconnected with the national grid and before households with off-grid solar systems get access to a grid connection. In Tanzania, development centres are considered as the unit for electrification, these are defined as settlements with at least 1500 inhabitants with existing social or administrative infrastructure (e.g., a school, dispensary, police station etc.), good access by road and some business activities. Tanzania's electrification plan leans heavily towards grid extension (i.e., 57% of the 3.8 million connection target) (Innovation Energie Développement, 2014), and is supplemented by a program to support the development of private mini grids (SIDA & DFID, 2016).

On the other end of the spectrum are countries with high medium voltage network coverage and unelectrified population settlements that are generally fewer and much smaller in size. These countries have less need for grid extension and mini grids and instead focus on grid densification—to connect unserved customers within reach of existing distribution transformers, and grid intensification—to connect housing clusters within 2.5 km of the existing medium voltage network. Off-grid solar is then considered for those who fall outside the reach of



grid intensification. In Kenya grid intensification is considered for housing clusters, within 2 km of the medium voltage network, which can justify short medium voltage line extensions with distribution transformers. The justification is based on whether the grid intensification costs significantly exceed the average cost of grid extension projects. Where this is the case consideration is then given to off-grid solar systems. Kenya's electrification plan therefore leans heavily toward grid densification and intensification (i.e., 56% of the 5.65 million connection target), and to off-grid solar (i.e., 40% of the connection target) (NRECA International, The World Bank, & ESMAP, 2018).

On-grid electrification plans are implemented through a phased approach with different criteria being used for prioritization. Since it takes time to increase the medium voltage network coverage, and because governments often have a long-term vision of eventually electrifying the whole country with the grid, this sometimes influences whether off-grid approaches are considered interim (i.e., as pre-electrification) or final.

In Tanzania, settlements are connected as the medium voltage backbone is expanded, with development centres in proximity of expanded backbone (up to 40 km) being prioritized. In Ethiopia, the grid program will be expanded from the centre to the periphery, while off-grid technologies are distributed in parallel from the periphery (beyond 25 km). The strategy acknowledges that many consumers targeted for the grid program will have to wait a long time for a connection, it tries to address this through the provision of off-grid solutions as an interim solution. Grid connections are prioritized for areas within 2.5 km of the grid, off-grid solutions provided as a pre-electrification solution for areas 2.5–25 km of the grid, and as a long-term solution for areas beyond 25 km. After the arrival of the grid, it is expected that off-grid solutions will support the quality and reliability of electricity by providing backup services. In Kenya, the sequencing of grid and mini grid projects over the implementation duration is based on prioritizing 'low hanging fruits' i.e., areas with the lowest average cost per connection and the highest potential for new connections. Rwanda's rural electrification strategy aims to prioritize high consumption areas when rolling out the electricity grid network e.g., productive use centres, agro processing industries and mining areas, that will drive economic growth and households capable of paying for the connection costs (Rwanda Ministry of Infrastructure, 2016).

The table above (Table 1) provides an overview of the electrification approaches and targets of the five countries considered for the study as extracted from the national electrification plans of these countries. The investments costs are based on unit cost estimates for the different electrification approaches. The per connection costs across the five countries for the different approaches are as

**Table 1** Overview of the electrification approaches and targets of the five countries considered for the study. Source: Authors' elaboration

Country	Date of Electrification Plan	Access level (Date)	Electrification Target (Date)	Number of Target Connections	Electrification Approach (Target connections)	Total Investment Costs
<b>Tanzania</b>	Jul 2014	18% (2013)	75% (2035)	3.8 million	On-grid – 99% (Grid densification – 42%, Grid extension – 57%) Off-grid – 1%	\$3.5 billion
<b>Rwanda</b>	Jun 2019	40.5% (2017)	100% (2024)	3.2 million	On-grid – 53% Off-grid – 47% (Off-grid solar – 38%, Mini grids – 9%)	
<b>Uganda</b>	Aug 2018	20.4% (2018)	60% (2027)	6.3 million	On-grid – 67% (Grid densification – 48%) Off-grid – 33% (Mini grids – 2%, Off-grid solar – 31%)	\$0.56 billion *Grid densification only
<b>Kenya</b>	Nov 2018	50% (2016)	100% (2022)	5.65 million	On-grid – 60% (Grid expansion – 5%, Grid densification – 45%, Grid intensification – 11%) Off-grid – 40% (Mini grids – 1%, Off-grid solar – 39%)	\$2.75 billion
<b>Ethiopia</b>	Mar 2019	34% (2018)	100% (2025)	14.2 million	On-grid – 35% (Grid densification – 32%, Grid intensification – 3%) Off-grid (final) – 7% (Mini grids – 2%, Off-grid solar – 5%) Off-grid (interim) – 58% (Combination of mini grids and off-grid solar)	\$4.1 billion

follows: grid densification US\$ 160–747, grid intensification US\$ 600–1057; grid extension US\$ 732–1273; off-grid solar US\$ 192–210; and mini grids US\$ 630–1712. NB: The off-grid solar cost per connection does not reflect the cost of the system, but rather the government's contribution; it is expected that these systems will be delivered by the private sector with customers contributing to the cost.

Electrification planning has identified electricity connection fees as a key barrier to the achievement of electrification targets. Connection subsidies and providing end users with payment plans for grid connection fees are common strategies for addressing this. Uganda has chosen to provide a subsidy of US\$ 160 for all new household connections within the secondary distribution network; to be connected new customers are only required to pay a US\$ 14 inspection fee after wiring their premises (Uganda Ministry of Energy & Mineral Development, 2018). Tanzania and Kenya combine a connection subsidy with a payment plan. In Tanzania, the fees (US\$ 111–201) must be paid in three subsequent monthly instalments before the customer is connected. In Kenya, the connection fee (US\$ 150) is paid over a 12-month period as part of the electricity bill. This approach enables a blanket electrification strategy to be deployed. In Ethiopia, the connection fee is based on electricity consumption and ranges from US\$ 0–370\$. Households in the first income quintile are exempted, while those in the second quintile pay US\$ 50. The fee increases progressively for subsequent income quintiles (Ethiopian Ministry of Water, Irrigation and Energy, 2019).

### Financing Plans for Electrification

The implementation of national electrification plans is a resource intensive undertaking and most of the plans considered for this study highlight, investment funding gaps, dependence on development partners, and the importance of private sector contribution and customer contributions from connection fees.

In Tanzania, the electrification plan is to be financed through levies (on electricity, pre-destination inspection and fuel) that contribute the rural energy fund (REF). Donors i.e., the governments of Sweden and Norway, also contribute to the REF. Private sector contribution is expected for off-grid projects; about 30% of the investment and preparatory costs. An annual funding gap of US\$ 123 million is estimated, and to partially address this the electrification program prospectus proposes that the electricity connection subsidy also be recovered from customers through a monthly surcharge of US\$ 5, which would represent a significant percentage of electrification costs for low consuming customers) (Innovation Energie Développement, 2014). In Uganda, the electrification plans are to be mainly funded through: (1) budgetary allocation from the Consolidated Fund (i.e., a fund consisting of all revenues generated by the central government, local govern-

ments, or other public agencies) and the transmission levy, (2) US\$ 80 million committed for last mile connections from the World Bank, the UK Department for International Development (via the Energizing Development Program), the German Development Bank (KfW), the European Union (via the African Development Bank) and the French Development Agency, and (3) government commitment of 50% of its annual rural electrification budget to finance connections (Uganda Ministry of Energy & Mineral Development, 2018).

The Government of Kenya has made progress towards reaching universal electricity coverage through the Last Mile Connectivity Program which has been supported by donor-financed agreements. The levels of investment for grid expansion, densification, intensification, and mini grids over the first two years of the electrification plan, are roughly equivalent to the funding that has been pledged for the Last Mile program. Funding for Last Mile activities beyond year three has not yet been secured. The African Development Bank, the World Bank, the European Investment Bank, and the French Development Agency have jointly pledged approximately US\$ 770 million, while years 1 through 3 requirements for densification and intensification are equivalent to approximately US\$ 1082 million. Kenya's electrification strategy also recommends the establishment of a National Electrification Trust Fund that could be used to (1) manage all treasury allocations or (2) only manage the pool of repayments from customers connected through the last mile program. It is estimated that the latter could grow to US\$ 280 million over the next 5 years (NRECA International, The World Bank, and ESMAP, 2018).

Ethiopia involved development partners in the design of its electrification program to facilitate buy-in and support. The grid component is to be funded through government contributions (15%), customer contributions (35%), and concessional finance and grants from development partners (50%). Customer contributions will be from connection fees charged; an average of US\$ 150 per connection. For the off-grid component, the government's contribution is 40%, with the balance expected to be covered by contributions from development partners and private sector resources. Most of the funding from development partners is yet to be secured, aside from a US\$ 375 million loan from the World Bank for the Ethiopia Electrification Program approved in 2018 (Ethiopian Ministry of Water, Irrigation and Energy, 2019).

### **Influence of Development Agencies**

Bhamidipati et al. demonstrates that transnational agencies (e.g., development agencies) tend to play a leading role in mobilizing resources, exert varying degrees of influence through financing projects and providing expertise, and

enjoy a superior position in global networks. This allows them higher bargaining power, with the opportunity to advocate and support their preferred solutions. They gain legitimacy due to their embeddedness and siting within the wider global network instead of specific actor characteristics as such (Bhamidipati et al., 2019).

A review of the history of World Bank policies toward aid to the electric utility sector over the last three decades of the twentieth century, shows a shift in policy from supporting large infrastructure projects of vertically integrated, government-owned utilities, to support for liberalization, privatization, and restructuring of the electric utility industry in potential recipient countries, with aid often hinging on reforms of this nature (Hausman et al., 2014). This demonstrates the bargaining power that transnational agency such as the World Bank have, and how they use it to influence electricity policy (including electrification approaches).

Recent World Bank electrification project designs suggest a shift towards results-based financing mechanisms (e.g., output-based aid). The Global Partnership on Output-Based Aid (GPOBA) is a global partnership program administered by the World Bank. It was established in 2003 to develop output-based aid (OBA) approaches across a variety of sectors—among them water, energy, health, and education. As of September 2015, through a portfolio of 44 projects with US\$ 228 million in commitments for subsidy funding and ongoing technical assistance activities, GPOBA is demonstrating that OBA can deliver a diverse range of services and lasting results for the poor (Khalayim, 2016). OBA has been used as a model to finance on-grid electrification activities in Ethiopia, Uganda, and Kenya. Ongoing World Bank electrification projects in Kenya, Rwanda and Burundi are now incorporating the use of results-based financing mechanisms to deliver electrification through solar home systems (Kenya (The World Bank, 2017b), Rwanda (The World Bank, 2020b) and Burundi (The World Bank, 2020a)).

### **The Role of Civil Society**

Broadly speaking some civil society organizations have been contributing to electricity access by implementing or supporting projects that pilot or demonstrate new or different approaches to delivering electricity access. These organizations use funds that they source from development partners and donors. Their approach ranges from developing and implementing projects or programs that provide demand side or supply side subsidies (e.g., results-based financing programs targeting underserved areas and low-income households (EnDev, 2021)) to programs supporting innovative technologies and business/delivery models that demonstrate alternative electrification approaches and drive systemic change. Some

of the alternative approaches nurtured by civil society have been subsequently adopted by governments. EnDev, for instance, has served as an incubator and source of innovation in the development of new types of results-based financing instruments in the energy access sector, some of which have subsequently been adopted for wider implementation by the governments of Kenya, Rwanda and Burundi for off-grid solar electrification, using funding from the World Bank (i.e., the projects mentioned in the section above).

### **Public-Private Partnership Models for Electrification**

If structured properly and offering appropriate incentives, Public-Private Partnerships (PPPs) can enlist private resources to supplement public resources, thereby increasing the pool of capital available to meet the electrification challenge. Some PPP strategies considered in the electrification plans reviewed include: (1) demand side subsidies—proposed in Rwanda, Kenya and Ethiopia to address off-grid solar affordability challenges for low-income households by directly reducing the retail cost, (2) supply side support—proposed in Kenya and Ethiopia in recognition of higher working capital costs and extra capital and operational expenditure costs associated with marketing off-grid solar in areas beyond the grid. This support is to avoid these costs being borne by the end-customer, either in terms of a higher system price or the absence of the service altogether, (3) market support services—proposed in Ethiopia in the form of collection of customer and market information, and customer aggregation for businesses, and (4) reducing costs, de-risking investment and providing credit lines for prospective mini grid developers in Tanzania and Ethiopia.

Governments also acknowledge that the ability of private sector to provide off-grid solar products or mini grid services affordably depends in part on exemptions from tax and import duties. Until 2014, most governments in East Africa offered tax and duty exemptions for equipment for the generation of solar and wind energy, including accessories, spare parts and batteries that use or store solar energy (which allowed appliances solar with solar PV systems to also benefit from tax and duty exemptions). However, the scope of these exemptions was subsequently limited to equipment used for generation and storage of energy, thereby excluding appliances, spare parts, and other accessories (Coffey International Development Ltd, 2019).

### **Electricity Concessions**

Electricity concessions represent one approach to increase the flow of private sector resources and expertise to electrification. Under concession arrangements, the state delegates to the private sector the right to provide a service yet retains

some control over the sector by incorporating in a concession contract or license the terms and conditions that will govern the infrastructure project or company. Concessions may be better understood when located along the continuum of PPP arrangements in the provision of infrastructure services. Options along that continuum vary based on the allocation of risks and responsibilities—from pure public to pure private ownership and operation (Guislain and Kerf, 1995).

Leasing represents a type of concession in which the public sector retains ownership of the assets as well as responsibility for making new investments and expanding the asset base. The private partner assumes responsibility for operating and maintaining the assets, providing the public service, and collecting payments for it. In exchange for the right to collect payments, the concessionaire makes regular lease payments to the asset owner. Strict concessions, as opposed to leases, require the private lessor to operate, maintain, and expand the asset in accordance with negotiated and specified terms. The lessor must return the asset, with all improvements, to the owner at the end of the concession period.

The rural electrification concessions that have been attempted in sub-Saharan Africa are:

1. Mini grid concessions—Mostly for isolated mini grids generating and distributing power. However, some serve as local distributors of power acquired from the national grid e.g., concession of small grid extensions—distribution-only networks that sell power generated by a national utility to local areas previously unconnected to the grid. Some mini grid concessions have been established through competitive selection (e.g., the WENRECo mini grid in the West Nile region of Uganda), while others have been selected and negotiated on a case-by-case basis. In Uganda, in the concessions for distribution only networks, the rural electrification agency finances, designs and constructs grid extensions and then leases the lines to private entities. The agency also covers major maintenance costs e.g., repair and replacement of transformers. However, electricity tariffs are designed to be cost reflective; the lease allows concessionaires to apply for tariff reviews. Uganda has 5 concessionaires operating under this model, who as of 2015, were together serving 40,000 customers (Castalia, 2015).
2. Solar Home System concessions—Contracting of private firms to install and maintain solar home systems in defined geographic areas (typically sparsely populated areas far from the grid). Solar companies compete to have an exclusive right to supply solar home systems or electricity from solar home systems to the area. The expectation is that in return for these exclusive rights, the concessionaire will invest in establishing supply and maintenance networks in the

target region. This was implemented in South Africa where the concessionaire was expected to assume the risks of capital investment, operations, collection, system losses, inflation, and fluctuating rates of interest and foreign exchange. The only shared risk was that of fluctuating demand, which was split between the participating municipalities and consumers. The latter were charged a minimum monthly service charge and the former were meant to provide a monthly operating subsidy to reduce the demand risks assumed by the concessionaire. Cost-recovery remained a significant operational challenge to the continued operation and expansion of these companies (Hosier et al., 2017).

3. Rural zonal concessions—enable governments to concede the rights to electrify a large area or zone. The terms of the contract may be technology-neutral, leaving the concessionaire free to deploy whatever technology they consider most advantageous to service the area. The area of a rural zonal concessions should be large enough to permit economies of scale. Concessionaires charge cost-recovery tariffs subject to regulatory oversight, but the rural electrification agency may help keep costs low by providing initial capital subsidies as part of its contribution to the partnership. In Senegal, which hosts the one case of a rural zonal concession in Sub-Saharan Africa, the risk associated with the prices of purchased power and fuel is shared between the concessionaire, the government (which provides subsidies to the utility that are passed through to concessionaires in pricing), and consumers (fuel-price pass-throughs). Owing to the complexity of risk-sharing formulations; the rules and standards governing multiple electrification technologies in the same contract; and the need for negotiation of capital cost subsidies, rural zonal concessions require strong institutional capacity both to establish and to regulate (Hosier et al., 2017).

The characteristics of the rural electricity market in developing countries limit the scope of concession arrangements and the potential of private sector participation. Because rural electrification has usually been inconsistent with the investment requirements of private investors, many concessionaires demand public grants or cost-sharing to meet the financing gap associated with rural electrification projects (Hosier et al., 2017).

### **Sufficient Electricity Access and Energy Mobility**

Monyei et al. argues that electrification policies in the global south are ambiguous and inconsistent with regard to (1) what constitutes sufficient electricity access and (2) how electrification projects can guarantee energy mobility for connected households (Chukwuka G. Monyei et al., 2019). Energy mobility is defined as the ability of households to increase their energy demand (which may result from an



increase in the number of electrical appliances they own or extending the usage of already owned electrical appliances) (C. G. Monyei et al., 2018).

Monyei et al. uses the South African example to illustrate the disparity and injustice in the distribution of resources between poor households that are grid connected and those that are off grid. Under the 2014 Free Basic Electricity (FBE) policy, poor households that are grid connected are guaranteed electricity supply of up to 50 kWh/month and peak electricity demand of up to 20A. In contrast, the 2018 Non-Grid Electrification Policy Guidelines identify solar home systems as a suitable temporary alternative to grid electricity and specify a 95Wp capacity solar home system with the capacity to supply 475 Wh/day (14.25 kWh/month). The system limits the appliances the household can use and the number of hours they can be used i.e., allows for the use of a DC colour television for four hours; four hours of lighting using high efficiency lights; the use of a portable radio for ten hours; and charging of mobile phones (NB: This is an upgrade from the 2012 policy guidelines which specified a 50Wp solar home system) (Energy Department: Republic of South Africa, 2018). Monyei et al. argues that advocating for implementation of solar home systems in poor off-grid households boosts rural peripheralization and caps electrical appliance ownership by households. Since most of these households cannot afford the systems (which are subsidized by government and implemented via a fee-for-service model), it follows that they will not be able to afford a system upgrade on their own.

The electrification plans of Kenya, Ethiopia, and Rwanda, prescribe off-grid solar systems capable of at least delivering Tier 1 level of electricity service to a household i.e., an entry level solar home system kits with a capacity of 11–21Wp. Ethiopia tries to address energy mobility through its pre-electrification strategy and the expectation that they will electrify the whole country with grid equivalent service in the long term. Off-grid solar and mini grids will be used to offer mid-term pre-electrification to 5 million households between 2.5–25 km from the existing grid. These households are expected to be connected to the grid between 2025 and 2030. An additional 3.3 million households are expected to get a grid connection by 2025, but since the rollout will take up to seven years, short-term pre-electrification through off-grid approaches will be used to provide them with access. Finally, about 1 million households located >25 km from the existing grid, and not expected to be connected at least-cost by the grid by 2030, are considered for long term pre-electrification (Ethiopian Ministry of Water, Irrigation and Energy, 2019).

Electrification planning therefore tries to guarantee households access to a minimum quantity of electricity (i.e., a Tier 1 level of service), and tries to address energy mobility through the expectation that all households will

eventually be connected to the grid. However, while commendable, the ambition to connect all households to the national grid it is unlikely to be realized in practice. As a starting point, electrification planning should therefore consider how households who are initially connected through an entry level solar home system (delivering Tier 1 level of service), can at least graduate to an off-grid solar system delivering Tier 2 level of service—more specifically along the trajectory of entry-level systems (11–21Wp) to basic systems (21–50Wp) to medium systems (50–100Wp) to high-capacity systems (>100Wp) as defined by the Lighting Global program (Lighting Global et al., 2020).

### **4.3.2 Economic Environment—What selection pressures, exerted by markets, are faced by different firms?**

#### **Rural Electrification Agency**

The International Energy Agency estimates that to reach full access by 2030 and maintain it to 2040 in Africa, would require multiplying current investment levels by five. The cumulative investment would reach more than \$2 trillion between 2019 and 2040 (or over \$100 billion per year). Half of the investment needs would be spent on grid expansion, reinforcement, and maintenance. Most of the rest would be for low carbon power capacity, where solar PV takes an important role, reaching almost \$25 billion per year on average (International Energy Agency, 2019). With electrification agencies heavily dependent on international funds from development agencies and banks, these agencies are effectively competing against each other for the same limited pool of funds for electrification. In addition, with pressure to achieve universal electrification by 2030, electrification agencies must stretch the funds they have at their disposal to deliver increasingly more connections per dollar spent.

#### **National Electricity Utility**

While most of the capital costs for electrification are not borne by national electricity utilities, experience has shown that electrification programs (especially large-scale blanket electrification programs) have resulted in increased operation and maintenance costs for utilities without a concomitant increase in revenue from newly connected customers.

The unviability of South Africa's electrification program was found to be a direct consequence of the household energy consumption being substantially lower than expected during the planning stages. Average energy consumption during the first 5 years after connection was reported as 83, 95, 106, 121 and 138 kWh/month, while a consumption per household of 400 kWh/month is

needed to break even. Thus demonstrating that the electrification programme was uneconomic and unsustainable without cross-subsidisation (National Electricity Regulator, 1998). Rwanda's Ministry of Infrastructure arrived at a similar conclusion, their Energy Sector Strategic Plan estimated that a consumer would need to use approximately 130 kWh per month to fund the cost of their own connection. However, results from their Electricity Access Roll-out Programme (which increased electricity access for households from 364,000 in 2012 to 590,000 in 2016) showed that almost half of the consumers connected were using less than 20 kWh per month (Rwanda Ministry of Infrastructure, 2016). Kenya's aggressive electrification program led to an increase in domestic consumers from 1.5 million in 2010, to 4.5 million in 2015. However, newly electrified consumers are lower consuming, and they brought down the average electricity consumption of domestic consumers in 2016 to 30% of 2009 levels. A deeper look into how consumption develops for newer customers showed that their consumption peaked at a lower level; between 20–25 kWh per month for rural consumers and 25–40 kWh per month for urban and peri-urban consumers (Taneja, 2018).

With most of the electricity revenue for national electricity utilities coming from a small number of large industrial and commercial consumers, electrification activities that focus on domestic consumers in rural areas are of no financial benefit to these utilities. With rural domestic consumers frequently falling within the subsidized segment of the tariff structure (the lifeline tariff), utilities struggle to cover the costs of supplying electricity in rural areas. While this could be addressed by reviewing the tariffs, the tension resulting from these utilities being government owned and/or government regulated, and the government being keen for electricity to remain affordable for all, prevents this from happening.

It is reasonable to suspect that the increased operation and maintenance burden resulting from grid extension projects, will subsequently result in a reduction in the responsiveness of the utility to electricity outages, and that this will be more so the further away that customers are from urban and peri-urban areas (i.e., as one approaches the external boundaries of the national grid). However, without accurate, disaggregated, and representative grid reliability measurements, this theory is difficult to prove.

Where national electricity utilities are already in a weak financial position (e.g., TANESCO in Tanzania), the approach of handing over grid extension projects financed and implemented by the electrification agency to the national electricity to operate and maintain is being reconsidered. In Tanzania, a consequence of the significant increase in grid extension projects will be an increase in operation and maintenance activities for TANSECO e.g., maintenance of the lines and substations, connection of customers (only a first wave of customers is connected

under the grid extension projects), extensions of the distribution network, installation of the logistics for pre-paid meters, and control of pre-paid meters. The implication is that TANESCO will need more personnel to cope with the high increase in the workload, as well as organizational or even institutional changes. The alternatives considered in Tanzania's National Electrification Program Prospectus include: (1) the creation of a rural electrification business entity in TANESCO with separate accounts, (2) the creation of private distribution companies which buy in bulk from TANESCO and assume all functions of a distribution company, (3) the outsourcing of the distribution activities to private companies under a management contract, and (4) the creation of a separate rural utility (Innovation Energie Développement, 2014).

### **Small Private Electricity Generation and Distribution Companies**

Mini grids are expected to have a key role in delivering electricity access in rural areas sub-Saharan Africa. IEA estimates that mini grids are the least cost option for 160 million people (about 28% of the full access target for rural areas) (International Energy Agency, 2019). However, jury is still out on whether purely private mini grids, which generate their own electricity and whose revenue is solely or primarily from retail electricity sales, will play a significant role. The indication currently is that purely private mini grids are still in the experimental phase, and that commercial investors will not invest until the business models for private mini grids are documented, and credible and robust evidence provided for investors to base decisions on. To address this, some mini grid developers are working to collect data from their installed mini grids to generate key success indicators for mini grids, which can be used to advise new investors in the field (Pedersen & Nygaard, 2018).

The main challenges faced by private mini grids include: (1) lower average revenue per user than the threshold required to make private mini grids viable, which is due to small, inconsistent or dormant users (inconsistent electricity use is linked to the seasonality of income), and (2) the difficulty in identifying and consolidating large numbers of commercially viable sites to sustainably cover their overhead costs (Muchunku et al., 2018).

Since most private mini grids do not currently generate enough revenue for private companies to depend on them exclusively, some mini grid developers double up as contractors, technology suppliers and/or service providers for other mini grid developers (including governments and donors) (Pedersen & Nygaard, 2018). Where private mini grids are interconnected with the national grid and can sell power to the grid (e.g., in Tanzania), these companies combine retail electric-

ity sales with independent power production and sale to the national utility under a long-term power purchase agreement.

Uganda has experience with public private partnerships through mini grid and grid extension concessions. Mini grid concessions were designed to encourage entrepreneurs to electrify regions on the principle of commercial viability, through delineating concession areas and providing a 20-year concession to generate, distribute and sell electricity within the concession area. However, this approach did not work as envisioned. The reasons for this included: (1) tariff caps, which meant the concessionaire was unable to cover operational costs, and (2) lack of capital or delays in accessing capital, which translated into significant delays in developing new generating capacity and expanding the distribution network to increase the customer base. The lessons learnt from piloting this approach were that (1) there was a significant commercial risk in rural electrification, and (2) there was a lack of commercial interest in financing electrification projects.

In response to these experiences, the concession model was restructured so that the government would finance and construct grid extension projects (through the rural electrification agency) and the lease these lines to private entities. The rationale was that simple operating agreements allocated less risk to the private sector. By creating concessions that are less focused on capital improvement, grid extension concessionaires would be able to focus more resources on customer relation and service quality. Uganda's experience with these grid extension concessions has shown some promise, with concessionaries able to consolidate large numbers of customers, and most of them being cash flow positive (or demonstrating the potential to be) (Castalia, 2015).

The profitability of grid extension concessionaires is ultimately dependent on revenue from electricity sales i.e., the number of customers, the quantity of electricity they consume, and the margin between the tariff that concessionaries charge and the bulk supply tariff they pay. The rural electrification agency is responsible for the design, extension, and upgrade of the distribution systems (i.e., to connect new customers), and major maintenance (e.g., the repair and replacement of transformers). Since the electrification agency's objectives are non-commercial, this translates into how they design and plan the distribution grids; they tend to focus on the quantity of connections rather than the quality (i.e., larger consumers). In addition, since concessionaires are dependent on the electrification agency for major maintenance, upgrades and extensions, implementation delays significantly affect revenue generation and growth. Concessionaires lack the capital to implement these themselves (as and when required), and then apply for reimbursement from the rural electrification agency (Castalia,

2015). Operational challenges and timely access to capital are the main barriers to the success of small grid extension concessionaires. However, these challenges do not appear to be insurmountable.

### **Off-grid Solar Companies**

The predominant business model for systems that can at least deliver Tier 1 level of electricity service (the minimum requirement for most national electrification plans) is the PAYGo model. The PAYGo value chain consists of the following segments: Product manufacturing, product design, software development (for sales and customer management), marketing and distribution, consumer financing and after-sales support. The PAYG model requires a responsive customer service system to register customers, address technical challenges, coordinate, and deploy technicians and follow up on defaulters (customers tend not to make repayments when their system is not working). First generation PAYGo companies are typically vertically integrated, dealing with all segments of the value chain, excluding manufacturing. However, the sector now has a diverse array of companies who only focus on specific segments of the value chain (Lighting Global et al., 2020).

The vertically integrated PAYGo business model inherently necessitates rapid growth and scale. Companies that implement this model require finance to develop new products, set up software platforms and distribution networks, expand into new markets and extend consumer loans. PAYGo companies do not accept deposits like a commercial bank, and are therefore dependent on funding from investors, lenders, and internal cash reserves to finance the consumer loans. The larger the value of a consumer loan and the lengthier its term, the more the working capital needed to fill the negative cash flow gap that is generated during the normal course of business. For example, a PAYGo company selling 1500 units per month (with a system cost of US\$ 200 and an 18-month repayment period), can create a loan book of approximately US\$ 1 million after five months (Lighting Global et al., 2020). As a result, working capital is necessary for a PAYGo business to scale up, and the lack of it will restrict growth. Financing needs for receivables are closely tied to the rate of revenue growth, and thus PAYGo companies will not remain reliant on external capital indefinitely. They will be able to finance most of their operations from internal cash flows once they reach scale and their growth rates slow (conversely, the more aggressive the company's growth, the greater the need for external funds). It is therefore estimated that they may need to rely on external sources of funding for 8–15 years (Bar-douille et al., 2017).

Market experience has shown that aggressive growth can affect long-term sustainability, creating a tension between maintaining both fast growth rate and high

portfolio quality. Fast growth can be generated by e.g., lowering the amount of customer down payment to make sales easier, extending repayment periods to increase addressable market, simplifying customer vetting processes, using part time contractors to maximize deployment speed, and using commissions that focus on rewarding acquisition (without putting sufficient emphasis on portfolio quality). However, while these approaches generate fast initial growth, they subsequently lead to low earnings and plateauing growth due to higher default rates and sales force churn. This not only leads to increased direct costs but also translates into negative word-of-mouth and lower penetration (Hybrid Strategies Consulting, 2017).

In response to both investor pressure and the challenges of building a sustainable off-grid solar business, PAYGo companies are shifting from growth at all costs to focus on unit economics, profitability, and sustainable scale. A key business model shifts is optimizing the customer relationship established and the knowledge generated from initial PAYGo sales (e.g., the creditworthiness of the customer) to offer other energy products and services (e.g., clean cooking solutions) and new products e.g., insurance, cash loans and other durable goods. Essentially increasing the value generated from each PAYGo customer secured.

The off-grid solar industry is also seeing the disintegration of the vertically integrated business model as companies find and focus on their niches and increase efficiency along the value chain. The industry is seeing more specialization, including from previously vertically integrated companies, as companies focus on financial sustainability and the off-grid solar industry grows large enough to support a wider array of specialist firms. Examples of this include, (1) emergence of third-party service providers offering PAYGo software to off-grid solar companies in different parts of the value chain, (2) large international companies are partnering with better positioned local distributors to reach unserved markets, rather than trying to establish large-scale last mile distribution themselves, and (3) several PAYGo companies have expressed interest in and the intent to outsource consumer finance to both microfinance institutions and larger finance institutions so that they can focus on their core capabilities (e.g., product or software) (Lighting Global et al., 2020).

Notably, off-grid solar software providers have developed an application programming interface that allows mini- or micro-grid developers to integrate off-grid solar PAYGo software into their platforms. This enables the integrated management of both mini grid and off-grid solar revenue streams (Lighting

Global et al., 2020). One implication of this is that companies no longer need to fit into either the mini grid or off-grid solar category, they can provide either or both depending on the context.

Customer repayments for PAYGo systems are dependent on the cost of the system and repayment duration; for more expensive systems, the repayment duration would need to be longer for the repayment fee to be lower. The effectiveness of the PAYGo model in delivering affordable electricity access is therefore dependent on the amount of daily/weekly/monthly repayment fee charged i.e., the extent to which this fee can be covered by the discretionary income of the target market segment (the lower the fee, the larger the potential market). The 2014 Africa Energy Outlook estimates that Kenyan households spend 3–5% of their income on electricity, with poor households spending the larger percentage (Global Energy Economics Directorate, International Energy Agency, 2014). This would indicate that the PAYGo model is primarily serving households in the US\$ 6–40 \$/day income range, who would not typically be considered as low income.

The 2020 Off-Grid Solar Market Trends Report provides estimates for the addressable market in sub-Saharan Africa for different off-grid solar products based on theoretical affordability. The addressable market is the population of households without electricity access, a product is considered affordable if the monthly cost is <5% of total monthly expenditure, and theoretical affordability assumes the payment of equal monthly instalments of the product cost throughout its lifecycle. Based on these assumptions the percentage of households in sub-Saharan Africa able to afford the different sizes of PAYGo solar home systems is as follows: entry-level systems (11–21Wp)—83%, basic systems (21–50Wp)—35%, medium systems (50–100Wp)—32%, and high-capacity systems (>100Wp)—10% (Lighting Global et al., 2020).

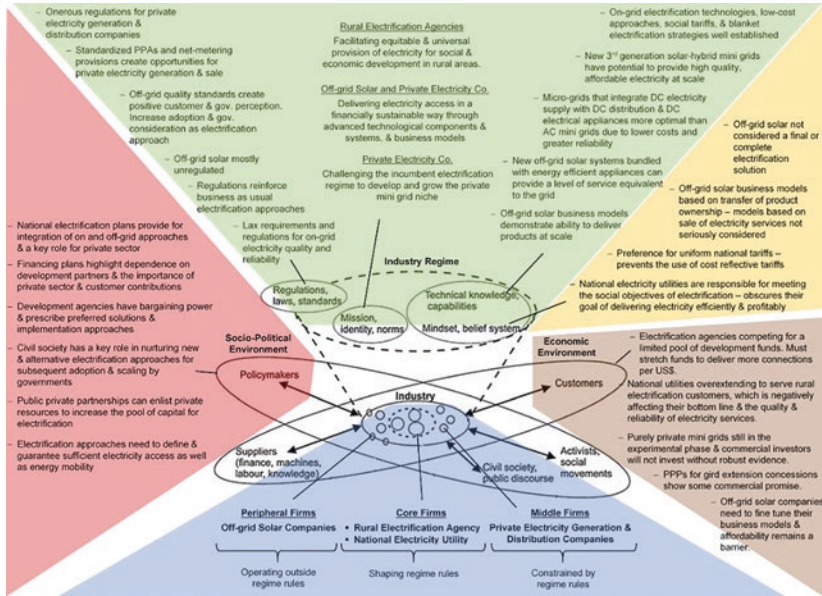
---

## 5 Discussion

### 5.1 Representing the Electrification Industry using the TEF—A Summary of the Findings

Geels illustrates the triple embeddedness framework using a diagram that highlights the relation between firms and the industry regime and their interactions in economic and socio-political environments. Figure 1 below uses the TEF diagram to summarize the findings from the sections above.





**Fig. 1** An illustration of the electrification industry using the triple embeddedness framework. (Source Authors' elaboration)

## 5.2 Postulating the Reorientation and Recreation Required to Make Progress Towards the Universal Electricity Access Goal

Acknowledging electrification funding constraints, the capacity limitations of national electricity utilities (in terms of their ability to provide a similar level of service to both urban and deep rural customers), and that new rural household connections are eating into the revenue margins of national electricity utilities, two challenges that should be addressed are, (1) increasing the flow of private sector resources and expertise to electrification, and (2) reducing the burden that on-grid (and mini grid) electrification activities are creating on national electrification utilities.

Grid densification and intensification should remain the preserve of national electrification utilities, especially in urban and peri urban areas. However, for grid intensification additional criteria should be used to determine which settlements

or housing clusters qualify i.e., intensification should be done for economic or socio-economic reasons, but not solely for social reasons. Thresholds based on standardized financial and economic analysis that applies realistic estimates of customer demand should be used to determine the settlements or housing clusters that qualify for grid intensification. For settlements or housing clusters that do not qualify for grid intensification, a combination of DC micro-grids and off grid solar systems should be considered.

Due to the industry lock-in created by the long-held perception that AC electricity is superior to DC electricity, the potential of DC micro-grids is not fully appreciated. ESMAP's projection that the development costs for third-generation AC mini grids will reduce, and their LCOE as a result, could be further extrapolated when considering DC micro-grids. Furthermore, because these systems are based on low voltage DC, they represent a low safety risk, which justifies the deregulation of these types of grids. Deregulation would allow DC micro-grid developers to completely bypass the onerous regulatory requirements applicable to the development of private AC mini grids and enable them to identify and serve household clusters in the same way that off-grid solar companies identify and serve individual households.

While deregulation implies that the question, 'what happens when the national grid arrives,' remain ambiguous, it is also reasonable to assume that if a household on a DC micro-grid has affordable and reliable access to all the electricity services they need and want, then the arrival of the national grid will be of no interest to them. When the grid arrives, customers with high power and energy demands can be specifically targeted. In addition, with AC-DC converters readily available in the market, it would be straightforward to supplement the capacity of the DC grid with electricity from the national AC grid, if required.

The availability and affordability of high efficiency DC appliances is invaluable for off-grid electrification efforts since they are suited to both off-grid solar systems and DC micro-grids. The demand for these appliances is still low (relative to AC appliances), making it difficult for manufacturers to achieve economies of scale and drive down costs. Government policy should therefore be targeted at addressing this by bringing down the cost and increasing demand. However, the opposite is happening, with import duty and taxes currently being levied on appliances used in off-grid solar systems.

The key challenges that need to be addressed to effectively use off-grid solar to meet national electrification targets are energy mobility and market distortion. The off-grid solar fee-for-service model has characteristics that suggest potential to address these challenges. The fee-for-service model provides a low entry requirement for the customer (in form of a connection fee) and lower ongoing

payments since the customer is only paying utility bills for the electricity service, rather than making payments to own the system. The model also provides for energy mobility; when customers are ready and willing to make larger utility payments, the off-grid solar provider can upgrade their system by e.g., increasing the generation and battery storage capacity to enable them to use their existing appliances for longer and/or use additional appliances. If an upgrade requires replacement of the existing system with a new system, then the off-grid solar provider can remove and refurbish the old system for reuse (i.e., to provide electricity services to a new customer), or sell it at its residual value on a cash or PAYGo basis.

The fee-for-service model for off-grid solar is well suited for the application of both a demand side and supply subsidy because it contributes to making electricity services more affordable for the consumer. In addition, as it is provided as a capital subsidy to the off-grid solar provider, it reduces the company's capital requirements and reduces the long payback period associated with the fee-for-service model. The model is also compatible with the application of results-based financing instruments.

Targeted subsidies would be the most effective way of addressing market distortion i.e., when using subsidies to deliver connections through off-grid solar. However, targeting low-income groups works best in countries with the institutional capacity to collect accurate income data, or where there is a comprehensive classification system in place e.g., the Ubudehe program in Rwanda, which classifies the Rwandan population into four categories based on income levels. Other countries implement more generic social protection programs with databases of beneficiary households. While these provide a good start for identifying who should benefit from an off-grid solar system subsidy, they are not exhaustive.

The fee-for-service model can mitigate against market distortion because of the following: (1) there is little overlap between the two models, which means they don't directly compete—one sells electricity as a service and the other sells off-grid solar products, (2) to date there has been limited use of the fee-for-service model in Eastern Africa, which means the playing field will be levelled for everyone—the subsidy won't provide one PAYGo company a unique advantage over another, (3) it will be possible to clearly communicate the distinction to customers i.e., PAYGo being used to provide an off-grid solar system on a commercial basis and fee-for-service being used to provide an off-grid solar electricity connection under the public electrification program, and (4) this distinction will facilitate the continuous monitoring, evaluation and review of the eligibility criteria being used to provide the subsidy and the effectiveness of how it is being applied.

A notable advantage of using PAYGo companies to provide off-grid solar connections is the potential to leverage their interest in also providing other energy products and services (e.g., clean cooking solutions) and new products e.g., insurance, cash loans and other durable goods. With SGD 7.1 also setting out targets for universal access to clean cooking solutions and governments keen to address this as well, the interest that PAYGo companies have in also delivering clean cooking solutions provides an opportunity for governments to combine electricity access programs with access to clean cooking programs and use the same companies to deliver on their targets.

The capacity of national electrification utilities to operate and manage existing grid extension and mini grid projects (i.e., those that have been or will be financed and developed through the rural electrification agency) should be evaluated. For existing projects (mini-grid and grid extension distribution networks) comprehensive electricity quality and reliability measurement protocols should be established and minimum performance requirements set. If, as determined by the regulator, the national electricity utility repeatedly fails to meet these performance requirements, then these projects should be withdrawn from the national electricity utility and leased out private electricity distribution and supply companies. These companies would purchase electricity in bulk from the national electricity utility for resale to end consumers, be allowed to develop their own renewable energy generating capacity to supply the distribution network and have the option to enter into a net metering arrangement with the national electricity utility. To optimize logistics and facilitate economies of scale for private companies, the rural electrification agency would have to develop suitable clusters of these projects when inviting private companies to bid for them.

Rural electrification agencies should also re-evaluate the current approach of unconditionally handing over grid extension and mini grid projects developed with rural electrification funds to national electricity utilities. Because most national electricity utilities are owned by the government, it is likely that they take up these projects out of obligation as opposed to commercial interest. Rural electrification agencies should instead invite both private companies and national electricity utilities to bid for the operation and management of newly established distribution networks.

The current practice of developing mini grids or grid extension projects is based on engineering, procurement, and construction (EPC) contracts i.e., turn-key projects procured by the rural electrification agency. A key flaw with this approach is that the EPC contractors have no long-term responsibility for the operation and maintenance of the distribution network. A procurement process that combines the EPC contract with a lease to operate and maintain the

distribution network could in theory result in a better-quality distribution network, because it would be in the interest of the EPC contractor to design and construct the grid in a way that makes it cost effective to operate and maintain. It also creates a larger financial opportunity for private companies, who would generate revenue from the EPC contract in the short term, and from electricity sales in the long term.

---

## 6 Concluding Remarks

When the triple embeddedness framework was developed, it had in mind industries associated with societal problems (e.g., decarbonisation and air pollution control) and large incumbent firms (mostly private) with bargaining power. While the societal problems could be addressed through sustainability transitions, the firms in these industries are reluctant to address them. The TEF postulates that the reorientation of incumbent industries towards radical innovations that address grand challenges will require pressure from consumers, policymakers, civil society, and social movements. The accumulation of such pressures may stimulate incumbent firms to overcome lock-in mechanisms and reorient towards more radical innovations.

This paper sought to apply the TEF to a different kind of societal problem i.e., universal access to affordable, reliable, and modern energy services (SDG 7), where the incumbents are public companies and government agencies (i.e., national electricity utility companies and rural electrification agencies) and the private firms in the industry are small and have little or no bargaining power. The application of the TEF to this problem was then used to identify (1) how to facilitate the foundational rethink (unlearning of existing beliefs) required, and (2) where and how external pressure could be exerted to achieve electricity access targets. The TEF provides a structured way of laying out the key aspects associated with electrification to create a picture that enables one to ‘see the forest for the trees’ and identify where and how to achieve more effective complementarity between on and off-grid approaches, and public and private firms.

---

## References

- Absolute Energy. (2021). Kitobo Island, lake victoria, Uganda: Our pilot project. Company website. <https://ae-capital.com/kitobo-island/>.
- African Development Bank. (2017). Uganda decentralized renewables development program. [https://www.afdb.org/fileadmin/uploads/afdb/Documents/Project-and-Operations/UGANDA\\_-\\_Approved\\_Decentralised\\_Renewables\\_Development\\_Program.pdf](https://www.afdb.org/fileadmin/uploads/afdb/Documents/Project-and-Operations/UGANDA_-_Approved_Decentralised_Renewables_Development_Program.pdf).

- Bacon, R. W., & Besant-Jones, J. (2002). Global electric power reform, privatization and liberalization of the electric power industry in developing countries. Energy & Mining Sector Board Discussion Paper Series, Paper No. 2. The World Bank Group. <https://documents1.worldbank.org/curated/en/226491468780869282/pdf/280850Global0electric0power0EMSo0no-02.pdf>.
- Bardouille, P., Shepherd, D., & Vanzulli, G. (2017). There is such a thing as too much, too fast: Avoiding ‘Mismatched Expectations’ in off-grid energy investing. Article. *Next Billion*. <https://nextbillion.net/there-is-such-a-thing-as-too-much-too-fast-avoiding-mismatched-expectations-in-off-grid-energy-investing/>.
- Barnes, D. F. (2011). Effective solutions for rural electrification in developing countries: Lessons from successful programs. *Current Opinion in Environmental Sustainability*, 3(4), 260–264. <https://doi.org/10.1016/j.cosust.2011.06.001>
- Bernard, B., Eberhard, A., Gaunt, T., & Marquard, A. (2008). South Africa’s rapid electrification programme: Policy, institutional, planning, financing and technical innovations. *Energy Policy*, 36(8), 3125–3137. <https://doi.org/10.1016/j.enpol.2008.04.014>
- Bhamidipati, P. L., Hansen, U. E., & Haselip, J. (2019). Agency in transition: The role of transnational actors in the development of the off-grid solar PV regime in Uganda. *Environmental Innovation and Societal Transitions*, 33(November), 30–44. <https://doi.org/10.1016/j.eist.2019.02.001>
- Bhatia, M., & Angelou, N. (2016). Beyond connections: Energy access redefined. Conceptualization Report 008/15. ESMAP, The World Bank Group. <https://openknowledge.worldbank.org/handle/10986/24368>.
- Bhattacharyya, S. C. (2013). Financing energy access and off-grid electrification: A review of status, options and challenges. *Renewable and Sustainable Energy Reviews*, 20(April), 462–472. <https://doi.org/10.1016/j.rser.2012.12.008>
- Castalia. (2015). *Evaluation of rural electrification concessions in Sub-Saharan Africa: Detailed case study—Uganda*. Castalia.
- Coffey International Development Ltd. (2019). Importation guidelines for solar PV products and systems in Kenya. Africa Clean Energy Technical Assistance Facility. <https://www.ace-taf.org/wp-content/uploads/2019/10/Importation-Guidelines-For-Solar-PV-Products-and-Systems-in-Kenya-2019-ACE-TAF.pdf>.
- Electricity Regulatory Authority. (2020). The electricity (Isolated Grid Systems) regulations, 2020. Uganda Gazette.
- EnDev. (2021). Results based financing. *Endev*. <https://endev.info/approach/results-based-financing/>.
- Energy and Petroleum Regulatory Authority. (2021). The draft energy (Mini Grid) regulations, 2021. <https://www.epra.go.ke/wp-content/uploads/2021/06/REVIEWED-ENERGY-MINI-GRIDS-REGULATIONS-2021.pdf>.
- Energy and Water Utilities Regulatory Authority. (2017). *The Tanzania electricity distribution code*. Energy and Water Utilities Regulatory Authority.
- Energy and Water Utilities Regulatory Authority. (2020). The electricity (Development or Small Power Projects) rules, 2020. <https://www.ewura.go.tz/electricity-regulatory-tools/>.
- Energy Department: Republic of South Africa. (2012). Non grid electrification policy guidelines. [https://www.cityenergy.org.za/uploads/resource\\_88.pdf](https://www.cityenergy.org.za/uploads/resource_88.pdf).
- Energy Department: Republic of South Africa. (2018). Non grid electrification policy guidelines for integrated national electrification programme. <http://www.energy.gov.za/files/policies/electrification/Non-Grid-Policy-Guidelines-for-INEP.pdf>.

- ESMAP. (2017). Rural electrification using shield wire schemes. A Knowledge Note Series for the Energy and Extractives Global Practice 2017/79. Live Wire. <https://www.esmap.org/sites/default/files/resources-document/120679-BRI-PUBLIC-24-10-2017-15-16-28-LWOKR.pdf>.
- ESMAP. (2019). Mini grids for half a billion people: Market outlook and handbook for decision makers. The World Bank Group. <https://openknowledge.worldbank.org/bitstream/handle/10986/31926/Mini-Grids-for-Half-a-Billion-People-Market-Outlook-and-Handbook-for-Decision-Makers-Executive-Summary.pdf?sequence=1&isAllowed=y>.
- Ethiopia Energy Authority. (2020). *Draft mini grid directive*. Ethiopia Energy Authority.
- Ethiopian Ministry of Water, Irrigation and Energy. (2019). *National electrification program 2.0: integrated planning for universal access*. Ethiopian Ministry of Water, Irrigation and Energy.
- Gaunt, C. T. (2005). Meeting electrification's social objectives in South Africa, and implications for developing countries. *Energy Policy*, 33(10), 1309–1317. <https://doi.org/10.1016/j.enpol.2003.12.007>
- Geels, F. (2014). Reconceptualizing the co-evolution of firms-in-industries and their environments: developing an inter-disciplinary triple embeddedness framework. *Research Policy*, 43(2), 261–277. <https://doi.org/10.1016/j.respol.2013.10.006>
- Global Energy Economics Directorate, International Energy Agency. (2014). *Africa energy outlook: a focus on energy prospects in Sub-Saharan Africa*. Global Energy Economics Directorate, International Energy Agency.
- Global Off-Grid Lighting Association. (2015). *GOGLA industry opinion towards the use of public and donor funding in the off-grid lighting industry: Adopted at AGM, Amsterdam, June 16, 2015*. Global Off-Grid Lighting Association.
- Global Off-Grid Lighting Association, and Get.invest. (2021). How end-user subsidies can help achieve universal energy access. Discussion Paper. Views From the Off-Grid Solar Industry. <https://www.gogla.org/resources/discussion-paper-how-end-user-subsidies-can-help-achieve-universal-energy-access>.
- Global Off-Grid Lighting Association, Lighting Global, Efficiency for Access Coalition, & Berenschot. (2020). Global Off-Grid Solar Market Report Semi-Annual Sales and Impact Data: January–June 2020. Global Off-Grid Solar Market Report. GOGLA. <https://www.gogla.org/global-off-grid-solar-market-report>.
- Global Off-Grid Lighting Association, Lighting Global, Efficiency for Access Coalition, and Berenschot. (2021). Global off-grid solar market report semi-annual sales and impact data: July–December 2020. Global Off-Grid Solar Market Report. GOGLA. <https://www.gogla.org/global-off-grid-solar-market-report>.
- Golumbeanu, R., & Barnes, D. (2013). Connection charges and electricity access in Sub-Saharan Africa. Policy Research Working Paper 6511. The World Bank Group. <https://documents1.worldbank.org/curated/en/499211468007201085/pdf/WPS6511.pdf>.
- Guislain, P., & Kerf, M. (1995). Concessions-The way to privatize infrastructure sector monopolies. Note No. 59. Viewpoint. The World Bank Group. <https://openknowledge.worldbank.org/handle/10986/11648>.
- Hausman, W. J., Neufeld, J. L., & Schreiber, T. (2014). Multilateral and bilateral aid policies and trends in the allocation of electrification aid, 1970–2001. *Utilities Policy*, 29(June), 54–62. <https://doi.org/10.1016/j.jup.2013.12.004>



- Hosier, Richard, Morgan Bazilian, Tatia Lemondzhava, Mitsunori Motohashi, & David Vilar de Ferrenbach. (2017). Rural electrification concessions in Africa: What does experience tell us? The World Bank Group. <https://documents.worldbank.org/en/publication/documents-reports/documentdetail/347141498584160513/rural-electrification-concessions-in-africa-what-does-experience-tell-us>.
- Hybrid Strategies Consulting. (2017). Reaching scale in access to energy: Lessons from practitioners. <https://www.adb.org/sites/default/files/publication/372436/access-energy-lessons.pdf>.
- Innovation Energie Développement. (2014). *United republic of Tanzania national electrification program prospectus*. Innovation Energie Développement.
- International Energy Agency. (2019). Africa energy outlook 2019. World Energy Outlook Special Report. <https://www.iea.org/reports/africa-energy-outlook-2019>.
- International Energy Agency, International Renewable Energy Agency, United Nations Statistics Division, The World Bank, & The World Health Organisation. (2020). Tracking SDG 7: The energy progress report 2020. <https://openknowledge.worldbank.org/handle/10986/33822>.
- Jacome, V., Klugman, N., Wolfram, C., Grunfeld, B., Callaway, D., & Ray, I. (2019). Power quality and modern energy for all. *Proceedings of the National Academy of Sciences*, 116(33), 16308–16313. <https://doi.org/10.1073/pnas.1903610116>
- Khalayim, O. P. (2016). Science of delivery for quality infrastructure and SDGs: Energy sector experience of output-based aid. ACS18763. World Bank Group. <https://documents1.worldbank.org/curated/en/481551468320685794/pdf/Energy-Sector-Study.pdf>.
- Law No.21/2011 Governing Electricity in Rwanda. (2011). Official Gazette directorate general.
- Levin, T., & Thomas, V. M. (2016). Can developing countries leapfrog the centralized electrification paradigm? *Energy for Sustainable Development*, 31(April), 97–107. <https://doi.org/10.1016/j.esd.2015.12.005>
- Lighting Global, Global Off-Grid Lighting Association, ESMAP, Vivid Economics, & Open Capital Advisors. (2020). Off-Grid solar market trends report 2020. International Finance Corporation. <https://www.lightingglobal.org/resource/2020markettrendsreport/>.
- Martinot, E., Cabraal, A., & Mathur, S. (2001). World Bank/GEF solar home system projects: Experiences and lessons learned 1993–2000. *Renewable and Sustainable Energy Reviews*, 5(1), 39–57. [https://doi.org/10.1016/S1364-0321\(00\)00007-1](https://doi.org/10.1016/S1364-0321(00)00007-1)
- Mini-Grids Partnership, Bloomberg New Energy Finance, & Sustainable Energy for All. (2020). State of the global mini-grids market report 2020: Trends of renewable energy hybrid mini-grids in Sub-Saharan Africa, Asia and Island Nations. [https://minigrids.org/wp-content/uploads/2020/06/Mini-grids\\_Market\\_Report-20.pdf](https://minigrids.org/wp-content/uploads/2020/06/Mini-grids_Market_Report-20.pdf).
- Monyei, C. G., Jenkins, K., Serestina, V., & Adewumi, A. O. (2018). Examining energy sufficiency and energy mobility in the global south through the energy justice framework. *Energy Policy*, 119(August), 68–76. <https://doi.org/10.1016/j.enpol.2018.04.026>
- Monyei, C. G., Oyedele, L. O., Akinade, O. O., Ajayi, A. O., & Luo, X. J. (2019). Benchmarks for energy access: Policy vagueness and incoherence as barriers to sustainable electrification of the global south. *Energy Research and Social Science*, 54(August), 113–119. <https://doi.org/10.1016/j.erss.2019.04.005>



- Muchunku, C., Ulsrud, K., Palit, D., & Jonker-Klunne, W. (2018). Diffusion of solar PV in East Africa: What can be learned from private sector delivery models? *WIREs Energy and Environment*, 7(3). <https://doi.org/10.1002/wene.282>.
- National Electricity Regulator. (1998). *Lighting up South Africa 1997/1998*. National Electricity Regulator.
- NewClimate Institute, & EED Advisory. (2019). The role of renewable energy mini-grids in Kenya's electricity sector: Evidence of a cost-competitive option for rural electrification and sustainable development. [https://ambitiontoaction.net/wp-content/uploads/2021/04/A2A\\_Mini-Grids-in-Kenya\\_201911.pdf](https://ambitiontoaction.net/wp-content/uploads/2021/04/A2A_Mini-Grids-in-Kenya_201911.pdf).
- NRECA International, The World Bank, and ESMAP. (2018). *The Kenya national electrification strategy*. NRECA International, The World Bank, and ESMAP.
- Odarno, L., Sawe, E., Swai, M., Katyega, M. J. J., & Lee, A. (2017). Accelerating mini grid deployment in Sub Saharan Africa: Lessons from Tanzania. World Bank Group. <https://documents1.worldbank.org/curated/en/532751512396163620/pdf/WP-acceleratingminigriddesploymentsubsaharanafrica-PUBLIC.pdf>.
- Pedersen, M. B., & Nygaard, I. (2018). System building in the Kenyan electrification regime: The case of private solar mini-grid development. *Energy Research and Social Science*, 42(August), 211–223. <https://doi.org/10.1016/j.erss.2018.03.010>
- Power Africa Off-grid Project. (2019a). Off-grid solar market assessment: Ethiopia. USAID. [https://www.usaid.gov/sites/default/files/documents/1860/PAOP-Ethiopia-MarketAssessment-Final\\_508.pdf](https://www.usaid.gov/sites/default/files/documents/1860/PAOP-Ethiopia-MarketAssessment-Final_508.pdf).
- Power Africa Off-grid Project. (2019b). Off-grid solar market assessment: Rwanda. USAID. [https://pdf.usaid.gov/pdf\\_docs/PA00W6C8.pdf](https://pdf.usaid.gov/pdf_docs/PA00W6C8.pdf).
- Rwanda Ministry of Infrastructure. (2016). *Rural electrification strategy*. Rwanda Ministry of Infrastructure.
- Rwanda Utilities Regulatory Authority. (2019). *Regulation No. 03/R/EL-EWS/RURA/2019 Governing the Simplified Electricity Licensing Framework for Rural Electrification in Rwanda*. Rwanda Utilities Regulatory Authority
- Sanghvi, A., & Gerritsen, B. (2012). Rwanda—Extending access to energy: Lessons from a Sector-Wide Approach (SWAp). Knowledge Series 013/12. ESMAP, The World Bank Group. [https://www.esmap.org/sites/esmap.org/files/ESMAP\\_Energy\\_Access\\_RwandaSWAp\\_KS013-12\\_Optimized.pdf](https://www.esmap.org/sites/esmap.org/files/ESMAP_Energy_Access_RwandaSWAp_KS013-12_Optimized.pdf).
- Sergi, B., Babcock, M., Williams, N. J., Thornburg, J., Loew, A., & Ciez, R. E. (2018). Institutional influence on power sector investments: A case study of on-and off-grid energy in Kenya and Tanzania. *Energy research & social science*, 41, 59–70.
- SIDA, & DFID. (2016). *Results based financing for renewable energy investments in green mini and micro grids: Rural energy agency operating guidelines*. SIDA and DFID.
- Swiss Centre for Development Cooperation in Technology and Management. (1992). *Village electrification*. SKAT, Swiss Centre for Development Cooperation in Technology and Management.
- Taneja, J. (2017). Measuring electricity reliability in Kenya. <https://blogs.umass.edu/jtaneja/files/2017/05/outages.pdf>.
- Taneja, J. (2018). If you build it, will they consume? Key challenges for universal, reliable, and low-cost electricity delivery in Kenya. Working Paper 491. Center for Global Development. <https://www.cgdev.org/publication/if-you-build-it-will-they-consume-key-challenges-universal-reliable-and-low-cost>.
- The Electricity Act of 2008, Tanzania. (2008).

- The Energy Act No.1 of 2019, Kenya. (2019). The Government Printer.
- The Energy and Petroleum Regulatory Commission. (2017). *Kenya National Distribution Code*. The Energy and Petroleum Regulatory Commission.
- The World Bank. (2017a). Making power affordable for Africa and Viable for its utilities: Tariff database. <https://datacatalog.worldbank.org/dataset/making-power-affordable-africa-and-viable-utilities>.
- The World Bank. (2017b). Kenya off-grid solar access project for underserved counties. Project Appraisal Document PAD2008. <https://documents1.worldbank.org/curated/en/212451501293669530/pdf/Kenya-off-grid-PAD-07072017.pdf>.
- The World Bank. (2018a). Ethiopia—Multi-Tier Framework (MTF) Survey. MTF Survey. <https://energydata.info/dataset/ethiopia-multi-tier-framework-mtf-survey-2018a>.
- The World Bank. (2018b). Rwanda—Multi-Tier Framework (MTF) Survey. MTF Survey. <https://energydata.info/dataset/rwanda-multi-tier-framework-mtf-survey-2018b>.
- The World Bank. (2019). Kenya—Multi-Tier Framework (MTF) Survey. MTF Survey. <https://energydata.info/dataset/kenya-multi-tier-framework-mtf-survey>.
- The World Bank. (2020a). Burundi solar energy in local communities project. Project Appraisal Document PAD2630. <http://documents1.worldbank.org/curated/en/247351583204580950/pdf/Burundi-Solar-Energy-in-Local-Communities-Project.pdf>.
- The World Bank. (2020b). Rwanda energy access and quality improvement project. Project Appraisal Document PAD4005. <https://documents1.worldbank.org/curated/en/819241600653622828/pdf/Rwanda-Energy-Access-and-Quality-Improvement-Project.pdf>.
- The World Bank. (2020c). Measuring energy access in multidimensional way through household surveys multi-tier energy access tracking framework global surveys. Results Briefs. November 2020. <https://www.worldbank.org/en/results/2020/11/10/measuring-energy-access-in-multidimensional-way-through-household-surveys-multi-tier-energy-access-tracking-framework-global-surveys>.
- The World Bank. (2021a). Doing business: Measuring business regulations. Doing Business. <https://www.doingbusiness.org/en/doingbusiness>.
- The World Bank. (2021b). Enterprise surveys: What businesses experience. Enterprise Surveys. <https://www.enterprisesurveys.org/en/enterprisesurveys>.
- Uganda Ministry of Energy and Mineral Development. (2018). *Electricity connections policy: Financing and implementation for connections 2018–2027*. Uganda Ministry of Energy and Mineral Development.
- Urpelainen, J. (2014). Grid and off-grid electrification: an integrated model with applications to India. *Energy for Sustainable Development*, 19(April), 66–71. <https://doi.org/10.1016/j.esd.2013.12.008>
- Verasol. (2020). Technical notes: IEC adopts quality standards for standalone solar energy kits. Technical Notes Issue No. 32. Verasol. [https://storage.googleapis.com/verasol-assets/IEC-Quality-Standards-for-Standalone-Solar\\_Final.pdf](https://storage.googleapis.com/verasol-assets/IEC-Quality-Standards-for-Standalone-Solar_Final.pdf).
- Verasol. (2021). Verasol product database. Product Database. Verasol Product Database. 2021. <https://data.verasol.org/>.
- World Bank, & IFC. (2021). Lighting Africa. Lighting Africa. <https://www.lightingafrica.org/>.

**Open Access** This chapter is licensed under the terms of the Creative Commons Attribution 4.0 International License (<http://creativecommons.org/licenses/by/4.0/>), which permits use, sharing, adaptation, distribution and reproduction in any medium or format, as long as you give appropriate credit to the original author(s) and the source, provide a link to the Creative Commons license and indicate if changes were made.

The images or other third party material in this chapter are included in the chapter's Creative Commons license, unless indicated otherwise in a credit line to the material. If material is not included in the chapter's Creative Commons license and your intended use is not permitted by statutory regulation or exceeds the permitted use, you will need to obtain permission directly from the copyright holder.





---

# Are Mini-Grid Projects in Tanzania Financially Sustainable?

Elias Zigah, Mamadou Barry and Anna Creti

---

## Abstract

While it is commonly acknowledged that mini-grids are the new pathway to bridging the high electricity access deficit in Sub-Saharan Africa (SSA), comparably few studies have assessed how existing regulations and tariff policies in SSA affect their potentials to attract the number of private investments required to scale-up deployments. Private investors' participation is particularly crucial to meet the annual electrification investment needs of \$120 billions in SSA. We study the regulatory framework, the tariff structure, and the subsidy schemes for mini-grids in Tanzania. Additionally, using an optimization technique, we assess the profitability of a mini-grid electrification project in Tanzania from a private investment perspective. We find that the approved standardized small power pro-

---

E. Zigah

African School of Regulation (ASR), European University Institute - Florence School of Regulation (FSR), Florence, Italy

e-mail: [mamadou.barry@chaireeconomieduclimat.org](mailto:mamadou.barry@chaireeconomieduclimat.org)

E. Zigah

e-mail: [elias.zigah@eui.eu](mailto:elias.zigah@eui.eu)

M. Barry · A. Creti

Chaire Économie du Climat, Université Paris Dauphine (PSL), Paris, France

e-mail: [mamadou.barry@chaireeconomieduclimat.org](mailto:mamadou.barry@chaireeconomieduclimat.org)

A. Creti

e-mail: [anna.creti@dauphine.psl.eu](mailto:anna.creti@dauphine.psl.eu)

© The Author(s) 2023

S. Groh et al. (eds.), *Electricity Access, Decarbonization, and Integration of Renewables*, Energiepolitik und Klimaschutz. Energy Policy and Climate Protection, [https://doi.org/10.1007/978-3-658-38215-5\\_10](https://doi.org/10.1007/978-3-658-38215-5_10)

233

ducers' tariffs and subsidy scheme in Tanzania still do not allow mini-grid for rural electrification projects to be profitable. A further study is required to identify successful business models and strategies to improve mini-grids profitability.

---

**Keywords**

Electricity Access · Mini-grids · Africa · Clean Energy Policy · Energy Regulation · Pricing

---

## 1 Introduction

Mini-grids are becoming the mainstream solution to electrification problems in high electricity access deficit countries, especially in Sub-Saharan Africa (SSA), where there is evidence of a significant gap between urban and rural population (IEA; IRENA; UNSD; WB; WHO, 2019). Given the enormous solar energy potential (about 300,000 Giga Watts) of SSA and the declining cost of renewable energy technologies, it is expected that by 2030, solar mini-grid solutions would provide more than 60% of rural electricity access in SSA (IEA, 2017a, b). Large-scale commercial deployments of mini-grids require a degree of profitability to ensure their financial sustainability (Peters et al., 2019). For this to happen, new regulations and cost-reflective electricity tariffs for small power producers are needed to incentivize private sector participation in the power sector. Private investors' participation is particularly crucial to meet the annual electrification investment needs of \$120 billions in the region (IEA, 2019). However, in most SSA countries, non-cost-reflective electricity tariffs as a result of institutional and political pressure to keep tariffs low and high commercial risk of mini-grid projects<sup>1</sup> are significant barriers that disincentivize private mini-grid developers from investing in the power sector (Eberhard & Shkaratan, 2012; Peters et al., 2019; IEA et al., 2019).

Amidst these challenges, Tanzania policymakers have implemented innovative policies and regulatory frameworks that have seen increased investments in small power projects. According to the World Bank (2019), Tanzania's comprehensive approach to mini-grid developments has achieved one of the fastest results in electricity access (56% and 73% increase in national and rural access rates respectively over the past decade) in SSA. The Tanzanian mini-grid model

---

<sup>1</sup>Commercial risks refer to low customer ability to pay for power and or low demand for power due to inefficient power use.

is anchored on public–private partnerships, where the government introduced a regulatory framework and legal and financial support to attract private mini-grid developers (Peters et al., 2019). This remarkable performance makes Tanzania a unique case of interest in Sub-Saharan Africa (Org et al., 2016). Therefore, this study is interested in understanding the factors that account for the proliferation of small power projects in Tanzania. Besides, given the need for increased private sector investments in mini-grid deployments to meet Tanzania's electrification needs, we further investigate whether the current tariff structure in Tanzania is cost-reflective for private commercial mini-grid developers.

Understanding mini-grid projects' profitability from an investment perspective is particularly crucial for designing optimal regulations and cost-reflective tariff schemes to attract adequate private sector investments in the power sector. However, this is a less explored area in the literature. Comparably, only a few quantitative studies have critically assessed how existing regulations and tariff policies in SSA affect mini-grid projects' potential to attract the number of private investments required scale-up deployments (Williams et al., 2018). From another perspective, there is no consensus in the literature about whether mini-grid projects in SSA are profitable enough to crowd in private financing of mini-grid projects. On the one hand, some researchers argue that mini-grid projects powered by renewable energy are economically viable and capable of paying-off their financing cost and earning adequate returns for investors (Arowolo et al., 2019). On the other hand, other studies also argue that mini-grid projects in SSA are not economically feasible; thus, it requires subsidies to enable investors to recover their production (Azimoh et al., 2016). This controversy about the profitability of mini-grid projects in SSA further strengthens the motivation of this paper.

Firstly, we review the regulatory policies and the operation of mini-grid systems in Tanzania to draw useful lessons for other SSA countries. Secondly, we use an optimization model to estimate the levelized cost of energy (LCOE) for three mini-grid project designs: Thermal, PV+Battery and Hybrid systems in Mafinga Town. The model uses a derivative-free optimization<sup>2</sup> to search for the least costly system. The LCOE for the least costly system is then compared with the regulated mini-grid tariff and the available subsidy schemes in Tanzania to access the mini-grid project's profitability. Mafinga Town, the study's specific location, is based on recommendations by the Electricity and Water Regulatory Authority (EWURA)

---

<sup>2</sup>Derivative-free optimization: It is a search algorithm that the model employs to find the most efficient system configuration that delivers the lowest LOCE; however, since this is a non-derivative method of optimization, the optimality cannot be guaranteed.

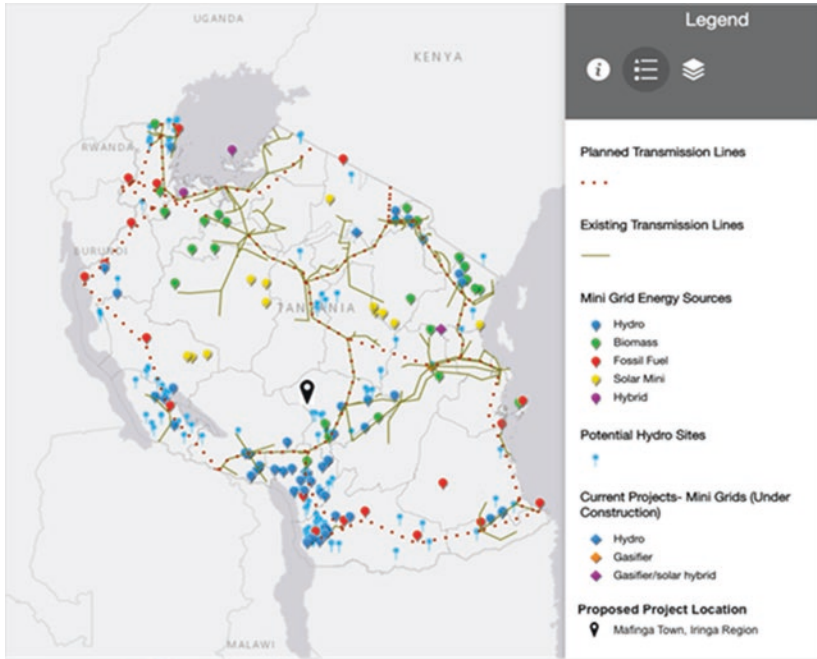
and the World Resource Institute (WRI). It is one of the preferred locations for private mini-grid investments in Tanzania. Additionally, this choice is also motivated by other factors, including high electricity need (92% unconnected households) and the presence of a high solar resource of 6.24 kWh/m<sup>2</sup>.

We organize the rest of the paper as follows. Section 2 presents a background of mini-grid development, regulation, financing, and operation in Tanzania. In Sect. 3, we describe both the methodology and the study area chosen for this paper. Section 4 discusses the results from our LCOE model vis-à-vis the current tariff structure in Tanzania. Section 5 concludes with some policy recommendations.

---

## 2 History of Mini-Grid Projects in Tanzania

Tanzania has rich experience in terms of mini-grid developments and regulations. The development and operation of mini-grid systems in Tanzania is dated as far back as 1908 during the colonial era, where the colonial masters developed mini-grid systems to power railway workshops, mining and agricultural industries (Org et al., 2016). During the same period, faith-based organizations also developed mini-grid systems to provide social services in a particular part of Tanzania. After independence in 1964, Tanzania continued to develop mini-grid systems to provide electricity access to decentralized communities in the country. Despite Tanzania's long history with mini-grid systems development, electricity access in the country is still low. According to the World Bank (2016b) household electrification survey, only 32.8% of Tanzanians have access to electricity. About 6.2 million rural households in Tanzania lack access to electricity (World Bank, 2016b). Given the dispersed type of settlement in rural Tanzania, grid extension is not a cost-effective option for extending electricity access to rural consumers. Therefore, TANESCO, the national utility company, uses standalone mini-grid systems powered by diesel and natural gas to extend electricity access to isolated communities. Tanzania currently has about 109 mini-grid systems in 21 regions operated by the national utility company, faith-based organizations, local communities, and private developers. Figure 1 shows the various types of mini-grid systems in Tanzania as of 2014. It highlights areas suitable for various mini-grid technologies based on the energy resources available in those areas. The black location indication on the map represents the specific area of interest for our study..



**Fig. 1** Mini-grid Projects in Tanzania. (Source: Authors’ elaboration from the WRI energy access map)

## 2.1 Regulatory Framework

After several years of operations, mini-grid developers in Tanzania still face some challenges, including a lack of regulatory framework and a specific tariff policy for mini-grid systems. The Electricity and Water Utilities Regulatory Authority (EWURA), which oversees Tanzania’s power sector regulation, introduces a specific regulatory framework for small power producers (SPPs). The regulatory intervention saw the implementation of standardized power purchase agreements (SPPA) and standardized power purchase tariffs (SPPT), popularly known as feed-in-tariffs (FiT) for SPPs. However, the first generation of feed-in-tariffs EWURA introduced was technology-neutral, which means that the FiT favours some technologies. The regulator also quotes the FiTs in the local currency, which exposes developers to high currency risks.



In response to the above challenges, in 2008, the regulator developed attractive mini-grid policies and regulatory frameworks that address the power sector's challenges and encourage further investments in renewable energy-based mini-grid systems in the country (Org et al., 2016). EWURA revised the SPP regulatory policies to provide clear policy guidance for SPPs connected to the national grid and mini-grid systems that serve isolated communities. The regulations require developers of mini-grid systems with capacities of 1 MW and above to obtain a license from the regulator before commencing operations. Mini-grid systems between 1 MW and 100 kW are required to register with the regulator, whereas projects below 100 kW require neither a license nor the regulator's tariff approval. Additionally, EWURA implemented the technologic-specific and size-specific feed-in-tariffs for various mini-grid technologies. Feed-in-tariffs for mini-grid systems connected to the national grid were denominated in the US dollar to reduce the currency risks. Also, EWURA removed taxes and import duties on renewable energy technologies to make them more competitive. Additionally, the EWURA introduced a mini-grid information portal and geospatial portfolio planning tools, which provide comprehensive information on mini-grid developments in Tanzania and reduce pre-site preparation costs significantly.

## **2.2 Financing Mini-Grid Systems in Tanzania**

Furthermore, from 2008 to 2014, the Tanzanian government, with support from the World Bank, established some financial support schemes to encourage local mini-grid developers to invest in the rural electrification program. The financial support scheme includes Smart Subsidies and Credit Line Facility. Under the Smart Subsidies, policymakers assist local developers with a matching grant of \$100,000 for environmental impact assessment and business plan development. Also, as part of the Smart Subsidies, developers benefit from a performance grant of \$500 for each household connected. However, renewable energy-based mini-grid systems require high initial capital investments that are often difficult for local developers to access from financial institutions due to doubts about mini-grid projects' economic viability (Ahlborg & Hammar, 2012). Therefore, the government introduced the US \$23 million credit line facility to provide commercial loans to small power producers. The loan facility is accessible through the Tanzania Investment Bank with 15 years payback period. Additionally, the World Bank has also made available \$75 million under the Renewable Energy Rural Electri-

fication Program to support the development of mini-grid projects between 2015 and 2019 (Org et al. 2016).

Despite the above regulatory interventions, there is still uncertainty among private developers about the fate of their investments in the arrival of the national grid. Up to date, there is no clear regulatory directive in that regard. However, the regulator envisages the following possible options. Firstly, the mini-grid operator can continue its operations as a small power producer and sell excess electricity to TANESCO. Secondly, in the event where the mini-grid operator is unable to compete with the national utility, the operator has the option to decommission its generation asset and buy electricity from TANESCO as a small power distributor. Lastly, the operator has the option to decommission its generation assets and sell-off its distribution assets to TANESCO.

### **2.3 Tariff Regulatory Policy in Tanzania**

Electricity regulators in SSA face the choice of applying the uniform national tariff or the cost-reflective tariffs for mini-grid systems operators.

The uniform national tariff is a fixed regulated rate that the regulator charges all customers irrespective of whether they are served by the national grid or by mini-grid systems. The idea behind this tariff scheme is to ensure equality and fairness across all consumer types. Mostly, utility regulators fix the electricity tariff for commercial mini-grid operators at the same rate as the state-owned utility service, which the government often subsidises below the cost of supply (Reber et al., 2018). Usually, the main drivers of the tariff scheme are political and social considerations. Mini-grid systems operators struggle to be competitive under the national uniform tariff scheme as their production costs are often significantly higher than the uniform national tariffs.

Under the cost-reflective tariff scheme, the regulator deregulates the electricity rates, and operators are allowed to charge rates that will enable them to recover the power supply costs and earn favourable returns on their investments. With the cost-reflective tariff scheme, economic considerations are the main determinants of the electricity rates underpinned by ‘willing buyer – willing seller agreements’. Therefore, it is perceived as a more effective scheme for attracting private mini-grid developers and encouraging efficient electricity supply (Economic Consulting Associates Viewpoint Mini-Grids: Are Cost-Reflective Tariffs Necessary? What Are the Options? Economic Drivers of Tariff Policy, 2017). However, it does not consider the consumer ability to pay for power.

According to the Economic Consulting Associates (ECA), there is a mid-way approach that serves as a third option for regulators. Under the mid-way approach, operators are allowed to charge regulated cost-reflective tariffs. However, the regulator and the operator must agree on the rate of financial returns and the payback periods (Economic Consulting Associates Viewpoint Mini-Grids: Are Cost-Reflective Tariffs Necessary? What Are the Options? Economic Drivers of Tariff Policy, 2017). In the case of Tanzania, the regulator is more inclined towards the mid-way approach. EWURA sets the mini-grid tariffs relatively higher than the grid rate (TZS203.11/kWh or \$0.08/kWh). However, EWURA determines the rate of financial returns and the payback periods for the mini-grid operators. EWURA uses the ‘avoided cost’ methodology to determine the electricity tariffs for small power producers in Tanzania. Moner-Girona et al. (2016) define avoided cost as “the price that the utility would have paid if it had to produce the power by itself or bought it.” In other words, it is the best-forgone alternative for a set of consumer groups at a particular location. Therefore, “the avoided cost, therefore, serves as the ‘floor’ price (a price specified in a market-price contract as the lowest purchase price of electricity, even if the market price falls below the specified floor price)” (Moner-Girona et al., 2016). Once the floor price is determined, a capacity band is applied to balance the tariff option for the various mini-grid technologies effectively. The approved standardized small power producers’ tariffs are then subject to review once every three years. Table 1 presents the recently updated approved tariffs for various mini-grid system operators in Tanzania.

**Table 1** Approved Standardised Small Power Producers Tariffs (Selling to the Grid). (Source: EWURA, 2019a)

Capacity (MW)	Minihydro USc/kWh	Wind USc/kWh	Solar USc/kWh	Biomass USc/kWh	Bagasse USc/kWh
0.1–0.5 MW	10.65	10.82	10.54	10.15	9.71
0.51–1 MW	9.90	9.95	9.84	9.34	9.09
1.01–5 MW	8.95	9.42	9.24	8.64	8.56
5.01–10 MW	7.83	8.88	8.34	7.60	7.55

### 3 Methods and Data

This section describes the methodology adopted by this study. We provide an overview of the selected community for the study, followed by the explanations on the LCOE and modeling approach. Later, we describe the data used for this project.

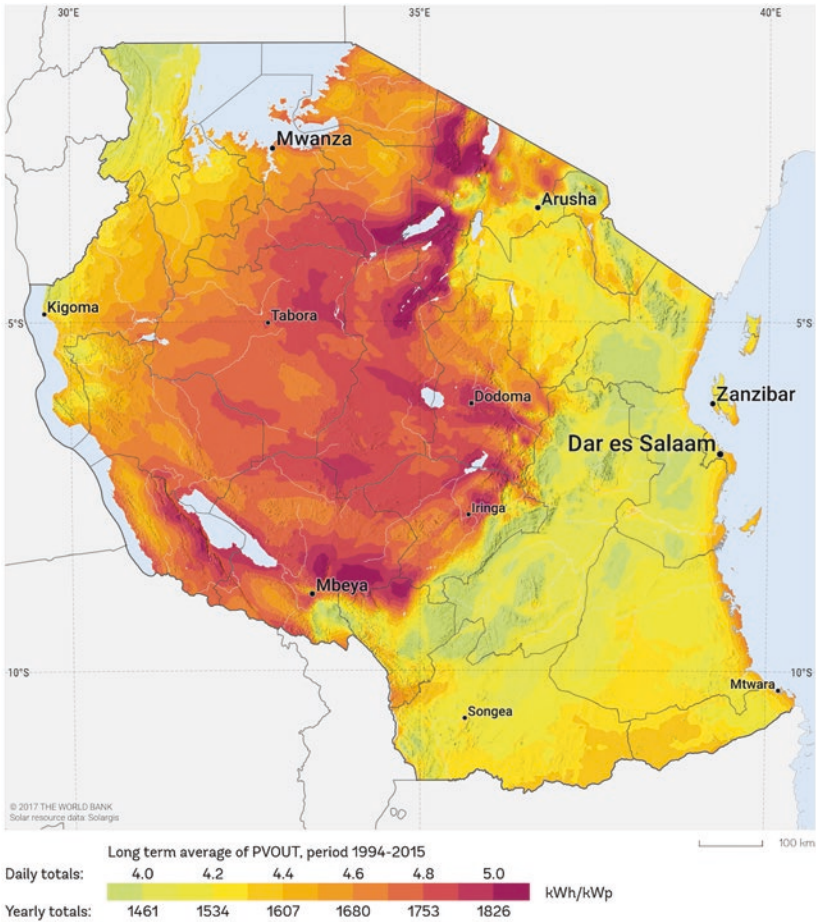
#### 3.1 Description of Project Site – Mafinga Town

Our study's area comprises five villages in Mafinga Town, located in the Mufindi district of central Tanzania (Iringa Region). The villages are Ivambinungu, Mkombwe, Pipeline, Malingumu, and Mjimwema. According to the 2012 Tanzania national census, Mafinga Town has a total population of 51,902 and a total household number of 12,532 (The United Republic of Tanzania, 2013). We choose Mafinga Town for our study because both EWURA and the World Resource Institute (WRI) identify the Mufindi district as a preferred location for mini-grid enterprise investment. Both in terms of the rich solar energy resource potential and the economic buoyancy of the district. However, the district has one of the lowest electrification rates in the region. Out of the total households in Mafinga Town, 11,629 households with about 92.8% do not have access to electricity. Kerosene remains the primary energy source of light in the entire Mafinga Township to the extent that its usage has decreased by only 3.8% between 2012 and 2016 (The United Republic of Tanzania 2017). The five villages considered in this study have a total unconnected population of 18,140 people and 4424 unconnected households. Figure 2 shows a satellite image of Mafinga Town with the five villages earmarked for mini-grid electrification.

#### 3.2 Solar Resource

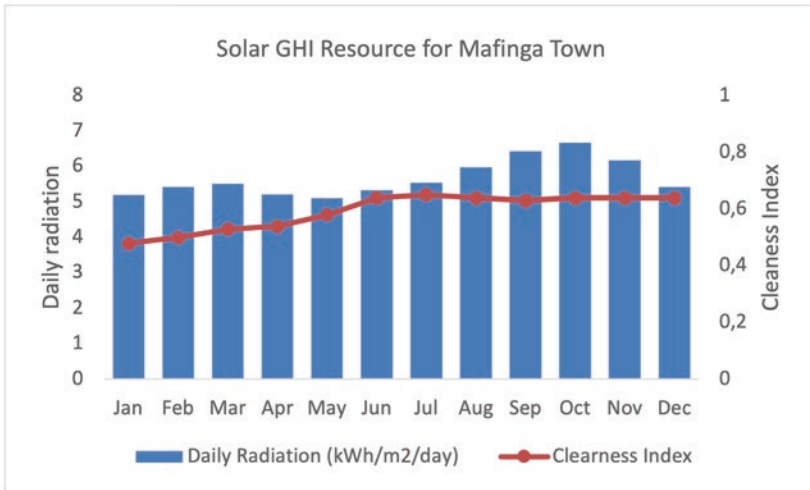
The Iringa region is considered to have one of the highest solar energy resources in Tanzania, as presented in Fig. 3 (ESMAP, 2015). The Global Horizontal Irradiance (GHI) of the region located at latitude 7.67 south and longitude 35.75 east is estimated at 6.24 kWh/m<sup>2</sup> (ESMAP, 2015). We use the HOMER software, linked to NASA's Surface Meteorology and Solar Energy (SSE) dataset, to estimate the region's average daily radiations. The SSE has proved to be an accurate and reliable source for providing solar and meteorological data for regions with sparse or





**Fig. 3** Photovoltaic Power Potential of Tanzania. (Source: World Bank Group, 2013)

best system configurations required to meet the load demand and estimate the system’s minimum capital and operating and maintenance costs over the project’s lifetime. HOMER uses a derivative-free optimization to search for the least costly system ranked by the LCOE, which is then compared with the approved mini-grid tariff to determine the mini-grid project’s profitability. Figure 5 illustrates the system design..



**Fig. 4** Solar GHI for Mafinga Town- Iringa Region, Tanzania. (Source: Authors' elaboration with data obtained from the SSE database, 2019)

### 3.4 Modelling the Energy Flow and the LCOE

We discuss the calculation of the energy flow and the simulation of the feasible system configuration components that feed into the financial model.

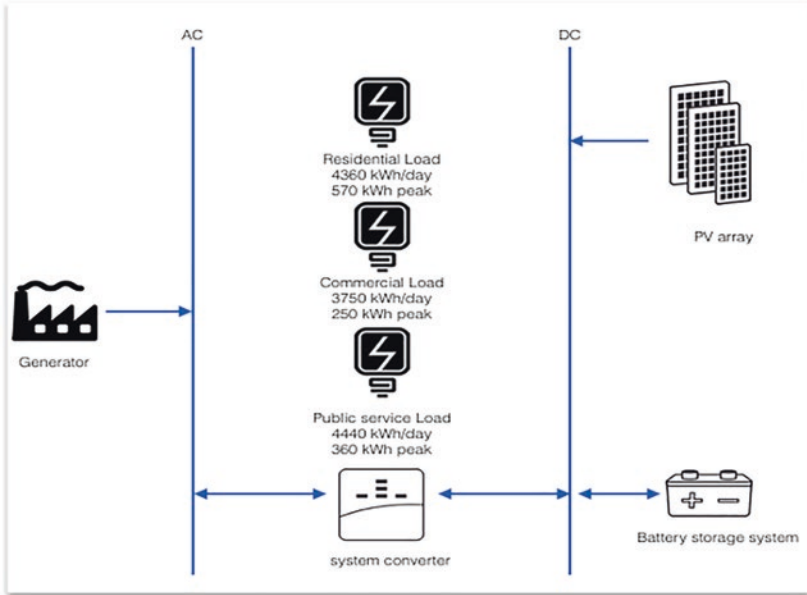
#### 3.4.1 The PV+Battery system model

The PV+Battery system consists of a PV array, a battery storage system,<sup>3</sup> and a converter<sup>4</sup> as illustrated in Fig. 5. The model uses Eq. 2 to simulate the PV array power output from a series of parameters, including the solar irradiance of Mafinga Town, temperature, degradation factor, PV module installation and system

<sup>3</sup>Battery Storage System (BSS) a group of batteries connected using a series or parallel wiring to store the excess power generated from the solar PV.

<sup>4</sup>Converter (Inverter): a device that converts the direct current (DC) from the PV array to alternating current (AC).





**Fig. 5** Proposed mini-grid system design. (Source: Authors’ own elaboration)

component specifications. We present the PV module's system optimized capacity in the LCOE result summary in Table 4 and the total net present cost and the annualized cost of the PV module in Appendix A.

Equation 1: PV array power output

$$P_{pv} = Y_{pv} f_{pv} \left( \frac{\bar{G}_T}{\bar{G}_{T,STC}} \right) [1 + \alpha_P (T_c - T_{c,STC})] \quad (1)$$

Where:  $Y_{pv}$  is the predicted average power output of the PV array under standard test conditions in kW,  $f_{pv}$  denotes the derating factor of the PV array,  $\bar{G}_T$  is the solar radiation incident on the PV array in the current time step expressed in (kW/m<sup>2</sup>),  $\bar{G}_{T,STC}$  represents the incident radiation at the standard test condition given as (1 kW/m<sup>2</sup>),  $\alpha_P$  is the temperature coefficient of power expressed as (%/°C),  $T_c$  equals to the ambient temperature of PV cell, average throughout the test (°C), and  $T_{c,STC}$  equals to the PV cell temperature of 25 °C under standard test condition.



### 3.4.2 Battery Storage System

“The variability and intermittency of solar generation require a flexible storage system” (Hoarau & Perez, 2019). Therefore, to ensure the system’s higher reliability, we consider a battery storage system consisting of several Lithium-Ion (Li-ion) batteries. Li-ion batteries have higher round-trip efficiency (97.5%) and a higher life span than lead-acid batteries. The temperature at which a battery is kept has a strong bearing on the storage system’s life span. According to Smith et al. (2017), batteries exposed to higher temperature often have a shorter life-span. Therefore, we consider a battery maintenance system consisting of air conditioning, active air circulation, and direct evaporative cooling to control the batteries’ temperature and improve the storage system’s useful life for the proposed project. Lockhart et al. (2019) referred to this maintenance system as the heating, ventilation, and air-conditioning (HVAC) configuration, which the Authors found to be very useful in prolonging a battery’s life-span in SSA. However, it costs relatively more to implement the battery maintenance system’s HVAC configuration; therefore, we consider \$20 per kWh as the battery maintenance cost, consistent with Lockhart et al. (2019).

The battery storage system (BSS) model requires the following values to calculate the total cost of the BSS: The Battery initial and replacement cost (\$/kW), maintenance cost (\$/kW), the life-span of BSS (years) and BSS total capacity. HOMER uses a simulation optimization technique to determine the optimal BSS capacity. We present the storage systems’ capacity in the LCOE result summary in Table 4. Table 4 shows the BSS initial cost, and in Appendix A the replacement cost and maintenance cost are included.

The life-span of the BSS is determined using the following Equation.

Equation 2: Life-Span of the storage bank

$$R_{\text{batt}} = \text{MIN} \left( \frac{N_{\text{batt}} \cdot Q_{\text{lifetime}}}{Q_{\text{thrpt}}}, R_{\text{batt},f} \right) \quad (2)$$

Where  $R_{\text{batt}}$  is the BSS’ life (yr.),  $N_{\text{batt}}$  is the number of batteries in the BSS,  $Q_{\text{lifetime}}$  is the lifetime throughput of a single battery (kWh),  $Q_{\text{thrpt}}$  and  $R_{\text{batt},f}$  represent the annual storage throughput (kWh/yr.) and storage float life (yr.) respectively.

### 3.4.3 Generator model

Following values are needed to model the LCOE for the diesel generator system design: the generator capacity, fuel consumption rate, generator efficiency rate, diesel cost (\$/litre), generator life-span and operation and maintenance cost. The

fuel cost is a significant cost parameter of the generator model, depending on the generator’s fuel consumption curve. The fuel consumption curve is defined as the amount of fuel the generator consumes to produce a kilowatt-hour of electricity; thus, it is linearly related to the electrical output as expressed in Eq. 3 and illustrated in Fig. 6.

Equation 3: Fuel consumption curve

$$F = F_0 \cdot Y_{gen} + F_1 \cdot P_{gen} \tag{3}$$

Where F denotes the total fuel consumption for each timestep,  $F_0$  represents the non-load fuel consumption per kW by the generator (fuel curve intercept coefficient expressed in (units /hr/kW)), and  $Y_{gen}$  represents the rated capacity of the diesel generator (kW).  $F_1$  is the marginal fuel consumption per kW of the generator output in each timestep (the fuel curve slope also expressed in (units /hr/kW)), and  $P_{gen}$  represents the electrical output of the diesel generator. For our proposed project, we use the system optimized  $F_0 = 32.4$  L/hr and  $F_1 = 0.236$ , which give the fuel consumption curve illustrated in Fig. 6.

The life-span of the generator represents the generator's actual operational life ( $R_{gen}$ ), after which a replacement is required. It is defined in Eq. 4 as the life-

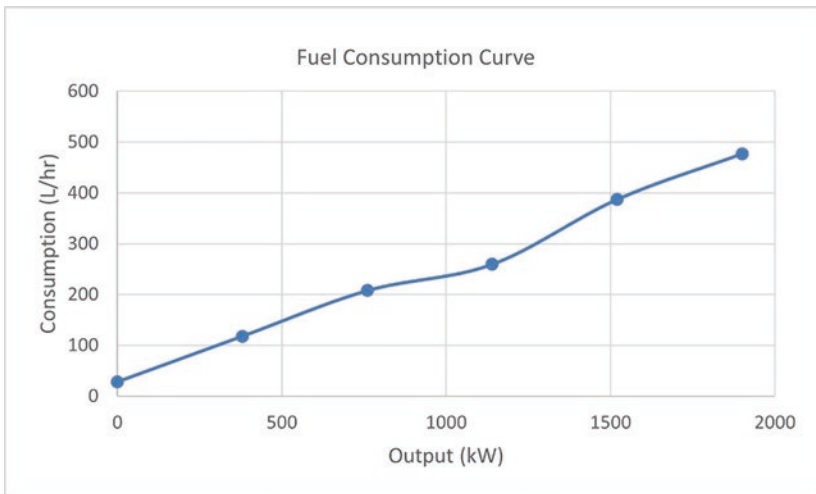


Fig. 6 Fuel Consumption Curve. (Source: Authors’ elaboration)

time hours of the generator ( $R_{\text{gen, hr}}$ ) divided by the number of hours the generator operates during the year ( $N_{\text{gen}}$ ).

Equation 4: Operational life-span of the generator

$$R_{\text{gen}} = \frac{R_{\text{gen, hr}}}{N_{\text{gen}}} \quad (4)$$

The summation of the annualized fuel cost, generator initial and replacement costs, and OPEX divided by the total electrical load served gives the LCOE for the generator model. We present the individual cost components in Appendix A and the generator's auto-sized capacity in Table 4 (LCOE result summary).

#### 3.4.4 Modelling the LCOE

The LCOE is the total annual cost of installing, operating and maintaining the mini-grid system divided by the total electricity served to consumers. We use Eq. 5 to calculate the LCOE,

Equation 5: Levelized Cost of Energy

$$LCOE = \frac{C_{\text{ann, tot}}}{E_{\text{served}}} \quad (5)$$

where  $C_{\text{ann, tot}}$  is the total annualized system cost per year expressed in (\$/yr). The  $E_{\text{served}}$  is the total electrical load served respectively.

#### 3.4.5 The Annualized Cost

As mentioned, the proposed mini-grid system has a life-cycle of 25 years, which implies that system components such as the battery storage system, converter and Genset will require replacements at particular times. Therefore, we assume a discount rate of 10% to translate all future cash flows of the project to present costs to estimate the proposed project's net present cost. This assumption is consistent with (Hittinger et al., 2015). The total NPC and annualized cost of each system components are presented in Appendices A and B.

Equation 6: Annualized Cost

$$C_{\text{ann, tot}} = CRF \cdot C_{NPC, \text{tot}} \quad (6)$$

Where  $C_{\text{ann, tot}}$  represents the total annualised cost,  $C_{NPC, \text{tot}}$  is the total net present cost (\$), CRF is the capital recovery factor (the present value of an annuity), and it is defined in Eq. 7 as:

Equation 7: Capital Recovery Factor

$$CRF = \frac{i(1+i)^N}{i(1+i)^N - 1} \quad (7)$$

Where:  $i$  and  $N$  represent the real discount rate and the number of years, respectively.

### 3.5 Data and Load Estimation

We obtain the local economic and techno-economic data from the Tanzania 2012 National Population Census, Tanzania mini-grid portal, World Bank Group, and the National Renewable Energy Laboratory (NREL) publications. We obtain about two-thirds of the cost assumptions from the World Bank Group's publication on mini-grids market outlook (ESMAP, 2019). Table 2 shows the cost assumptions used in this study.

### 3.6 Electricity Demand Estimation

We rely on data from the following two sources to estimate the potential electricity demand from the five villages in Mafinga Town (Ghosh Banerjee et al., 2017); (Williams et al. 2017). Ghosh et al. (2017) include case-studies of two mini-grids systems in Tanzania, of which the Mwenga mini-grid project is of comparable size as the proposed project, in terms of similar household types, commercial, community and agricultural activities. Likewise, the study by Williams et al. (2017) is based on case-studies of mini-grid projects in four different Tanzania communities, which exhibit similar daily load consumption reported by the World Bank report. The Rural African load profile tool simulates the hourly electrical load profile for various households and commercial entities commonly found in rural Sub-Saharan Africa. Thus, based on the data obtained from the world bank publication and validated with (Williams et al., 2017), we used the Load profile tool to simulate the potential electricity demand for Mafinga Town. Table 3 presents the total estimated daily, yearly loads and the peak demand for the various consumer types in the five villages in Mafinga Town. The projected load profile for Mafinga Town is exhibited in Fig. 7.

**Table 2** Cost assumptions of the input parameters. (Source: see table)

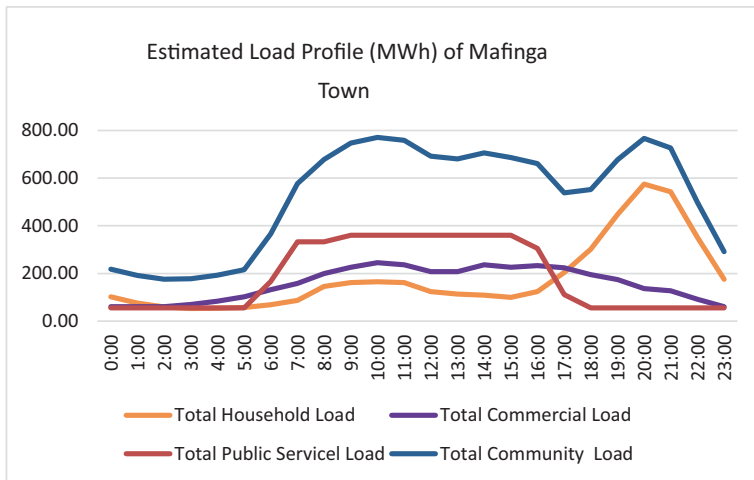
Assumptions	Base Case	Future Projections	References
Solar generation			
Installed PV cost [\$/kW]	\$230	\$140	Estimated 39% cost reduction by 2030 (ESMAP, 2019)
PV O&M \$/kW	\$10	\$6.1	
Useful life	25 years	25 years	
Battery storage cost [\$/kWh]	\$263	\$95	Estimated 64% cost reduction by 2030 (ESMAP, 2019)
Battery useful life	15 years	15 years	
Battery O&M [\$/kWh-installed]	\$20	\$10	
Converter costs [\$/kW]	\$115	\$58	Estimated 50% cost reduction by 2030 (ESMAP, 2019)
Converter replacement cost [\$/kW]	\$58	\$58	
Converter useful life	15 years	15 years	
Thermal generation			
Diesel genset cost [\$/kW]	\$500	\$400	NREL and ASES ( <a href="https://www.nrel.gov/">https://www.nrel.gov/</a> )
Useful life	10 years	10 years	
Fuel cost [\$/L]	\$0.95/L	\$0.95/	(EWURA, 2019a, b)
Fuel escalation rate	3%	3%	NREL and ASES
System fixed and operational cost			
Total distribution system costs	\$160/client	\$160/client	(ESMAP, 2019)
Smart Meters	\$40/client	\$30/client	
Pre-operating soft costs [\$/kW]	\$2'300	\$2'300	(Reber et al., 2018) and NREL, (ESMAP, 2019)
Annual labor costs [\$/year]	\$38'000	\$38'000	
Annual land lease costs [\$/year]	\$800	\$800	

## 4 Results

This section discusses the results of the HOMER model. Table 4 shows the possible system configuration, such as the system components' capacity, the system cost summary, and the LCOE for the three system designs. Figure 8 demonstrates

**Table 3** Load Profile Output Table. (Source: Author’s estimation)

	Household Load	Commercial Load	Public Service Load	Total Community Load
Total MWh/day	4.36	3.75	4.44	12.55
Total MWh/year	1'591.40	1'368.75	1'620.60	4'580
Peak MW/day	0.57	0.25	0.36	0.77
Reserve Margin	10%	10%	10%	10%
Timestep variability	16%	16%	16%	16%
Daily Variations	20%	20%	20%	20%
Load Factor %	22%	27%	27%	31%



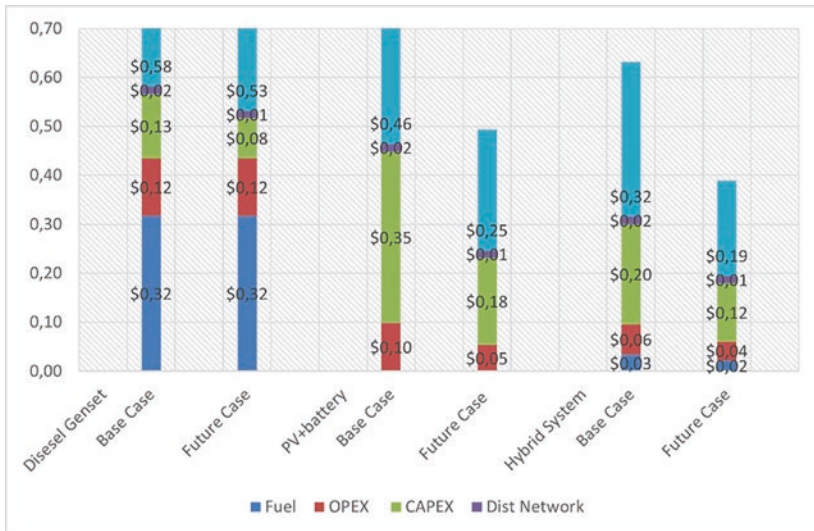
**Fig. 7** Estimated Load Profile of Mafinga Town. (Source: Authors’ estimation)

the breakdown of the LCOE by system cost components. Appendix A and Appendix B offer the detailed cost summaries for the Base Case and the Future Case.

The LCOE vary significantly from one technology option to another. The Hybrid System emerges as the most cost-effective solution with approximately 89% penetration of renewable energy generation (PV+Battery) throughout the year. Its optimal system configuration is expected to generate 16.75 MW of

**Table 4** LCOE Result Summary. (Source: Authors' elaboration)

	Diesel Genset	PV+Battery	Hybrid System
PV capacity	–	5095 kW	2849 kW
Battery (LA) capacity	–	24,122 kWh	10,625 kWh
Converter capacity	–	2276 kW	1460 kW
Diesel generator capacity	1900 kW	–	1900 kW
NP life-cycle cost	\$33'495'760	\$26'713'380	\$18'186'120
Initial Capital cost	\$1'837'100	\$20'231'101	\$11'922'078
Operating Cost	\$2'518'502	\$515'677	\$498'315
<b>LCOE</b>	<b>\$0.58</b>	<b>\$0.46</b>	<b>\$0.32</b>
Total emission/yr	4,067,580 kg	0.00 kg	451,083.50 kg
SSP Tariff \$/kwh	\$0.10	\$0.10	\$0.10
<b>Difference \$/kwh</b>	<b>–\$0.48</b>	<b>–\$0.37</b>	<b>–\$0.22</b>
<b>Annual Loss</b>	<b>–\$2'213'876</b>	<b>–\$1'675'193</b>	<b>–\$995'855</b>



**Fig. 8** LCOE Breakdown. (Source: Authors' elaboration)

electricity per day, approximately 22% more than the estimated load demand of 12.55 MW per day. It has a total life-cycle cost (net present cost) of \$18.20 million and requires an electricity tariff of 32 cents to breakeven. The PV+Battery System appears to be the second cost-effective solution and compared to the Hybrid System, it will cost consumers extra 14 cents per kWh of electricity consumed. The PV+Battery system generates almost twice the projected electricity demand (23.17 MWh per day) to ensure high system reliability, indicating that the feasible system configuration is over-sized to make-up for the PV's intermittent generation. The Diesel Genset option is the least cost-effective solution. Besides, it has a higher impact on the environment and produces about 4,067 tonnes of greenhouse gas emission per year. It also produces about 16% excess electricity to ensure high system reliability. The cost of fuel accounts for about half (\$0.36/kWh) of the LCOE. However, under the PV+Battery and the Hybrid Systems, capital expenditure (CAPEX) accounts for more than half of the LCOE (see Fig. 8).

#### **4.1 The Profitability of the Proposed Mini-Grid System**

The approved tariff for the proposed mini-grid project is approximately 10 cents per kWh, below the LCOE of the most cost-effective solution for the proposed project – the Hybrid System. The Hybrid system requires a minimum of 32 cents per kWh to recover its cost of investments. Thus, selling electricity at the current rate of 10 cents per kWh for the proposed mini-grid system will result in a loss of 22 cents on every kWh of electricity produced, which amounts to a total gross loss of \$998,145 per year. Besides, EWURA approves an 18.5% return on equity for SPPs. Therefore, for the proposed mini-grid project to be financially sustainable, it must retail its electricity at a minimum rate of 38 cents per kWh, which implies that the project will require a subsidy of approximately \$1 million per year to be financially feasible.

However, most of the subsidies for mini-grid projects in Tanzania were implemented between 2008 and 2014 (Org et al., 2016). Even if we apply the subsidies that used to be in place (Marching Grant and Performance Grant), they will not be enough to make the project profitable. Therefore, we argue that under the current tariff scheme in Tanzania, mini-grid projects are not financially viable from an investment perspective.



## 4.2 Sensitivity Analysis

Although the Hybrid System emerges as the most cost-effective solution, the competitiveness of the PV+Battery system is highly influenced by parameters such as cost of capital, system reliability and capital investment cost. Therefore, given the rapidly declining cost of renewable energy technologies, we performed a sensitivity analysis on the LCOE for the three system designs using the 2030 cost estimates by ESMAP (2019), different discount rates from 3 to 15% and annual capacity shortages from 5 to 30%.

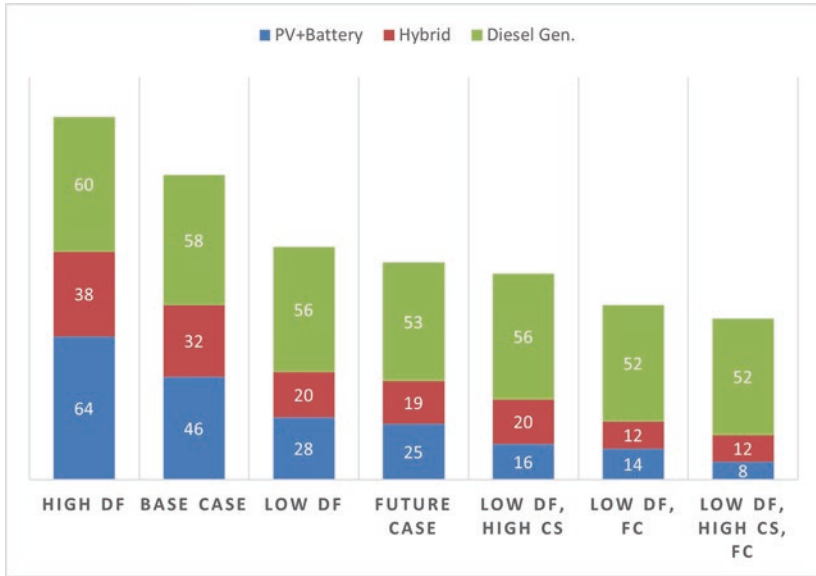
We assess the effect of all the variables on the LCOE and find that combining the three factors will deliver the lowest LCOE between 10 cents per kWh and 7 cents per kWh. However, this is an extreme case, which in the context of Tanzania, is neither feasible now nor by 2030. This is based on the assumption that given the high investment risks associated with mini-grid projects in SSA, most private investors prefer to discount their future cash flows at the interest rates they anticipate receiving over the life of their investments (Williams et al., 2018; Grant Thornton, 2018). Thus, it is less likely for solar mini-grid projects to be discounted at the rate of 3% in SSA from an investment perspective. Therefore, this reinforces our argument that private commercial mini-grid projects in Tanzania purposely for rural electrification are not profitable even by 2030. Figure 9 illustrates the sensitivity of the LCOE to all three variables.

---

## 5 Conclusion and Policy Implication

Our analysis shows that despite a well-structured mini-grid tariff system and subsidies initiatives in Tanzania, operating privately-owned mini-grid systems in rural communities is not financially feasible. Further, we describe some of the challenges with the effective deployment of mini-grid systems in Tanzania. Specifically, we highlight non-cost-reflective tariff for mini-grid projects and the commercial risk of mini-grid projects as significant challenges facing the commercial deployment of mini-grid systems in Tanzania. Therefore, the government may consider the following:

Firstly, EWURA may want to review its tariff scheme for mini-grid developers to reflect the electricity supply cost from an off-grid system to serve isolated rural communities. This is particularly important because it appears the current tariff scheme is based on mini-grids systems connected to the grid. Meanwhile,



**Fig. 9** Sensitivity analysis using DF<sup>5</sup> and CS<sup>6</sup> for the 2030 cost (FC<sup>7</sup>) estimates. (Source: Authors’ elaboration)

the grid-connected mini-grids enjoys significant trade-offs between buying unmet load from the grid and selling excess load to the grid and oversizing the system to ensure system reliability. This option is rarely available to off-grid developers except for the latter, which is considerably more expensive.

Secondly, given the Hybrid and PV+Battery systems’ high initial capital requirement, the government may consider expanding its loan facilities to enable private developers to access adequate funding for their projects at a considerably low rate.

Lastly, as pointed out earlier, with an annual capacity shortage of 15%, the PV+Battery system emerges as the most cost-effective solution for providing electricity at the rate of 28 cents per kWh (approximately 40 percent decrease in

<sup>5</sup> Discount Factor: High DF = 15% and Low DF = 3%

<sup>6</sup> Capacity Shortage: 25% (about 18 h of power supply per day).

<sup>7</sup> Future cost: 2030 cost estimates.

LCOE). In this regard, we recommend that private developers consider complementary solutions such as Solar Home Systems to make-up for the capacity shortage if necessary.

**Acknowledgements** The authors appreciate the support of the Climate Economics Chair. We thank HOMER Energy for granting us a temporal license to use the HOMER software for our analysis. The paper has also benefited from Quentin Hoarau, Come Billard, Olivier Rebenaque, Théotime Coudray and Wale Arowolo comments. All errors remain the responsibility of the Authors.

## Appendix A: Base Case Cost Summary

**Table 5** Cost Summary – Hybrid System. (Source: Authors' elaboration)

HYBRID SYSTEM						
<i>Net Present Cost</i>						
Name	CAPEX	OPEX	Replace- ment	Salvage	Fuel	Total
Genset	\$950'000	\$741'593	\$398'506	−\$58'376	\$1'930'000	\$3'961'723
Li-Ion Battery	\$2'790'000	\$2'000'000	\$430'367	−\$54'588	\$0	\$5'165'779
PV Array	\$7'120'000	\$358'140	\$0	\$0	\$0	\$7'478'140
Converter	\$167'938	\$0	\$34'466	−\$6'309	\$0	\$196'095
System FC & VC	\$887'100	\$487'733	\$0	\$0	\$0	\$1'374'833
<i>Annualized Cost</i>						
Genset	\$75'574	\$58'995	\$31'702	−\$4'644	\$153'463	\$315'090
Li-Ion Battery	\$222'297	\$159'375	\$34'236	−\$4'343	\$0	\$411'565
PV Array	\$566'620	\$28'491	\$0	\$0	\$0	\$595'111
Converter	\$13'360	\$0	\$2'742	−\$502	\$0	\$15'600
System FC & VC	\$70'570	\$38'800	\$0	\$0	\$0	\$109'370

**Table 6** Cost Summary – PV+Battery. (Source: Authors' elaboration)

PV+BATTERY					
<i>Net Present Cost</i>					
Name	CAPEX	OPEX	Replacement Cost	Salvage	Total
Li-Ion Battery	\$6'340'000	\$4'550'000	\$932'487	–\$170'684	\$11'651'803
PV Array	\$12'700'000	\$640'495	\$0	\$0	\$13'340'495
System Converter	\$261'785	\$0	\$53'726	–\$9'834	\$305'677
System FC & VC	\$887'100	\$487'733	\$0	\$0	\$1'374'833
<i>Annualized Cost</i>					
Li-Ion Battery	\$504'683	\$361'830	\$74'181	–\$13'578	\$927'116
PV Array	\$1'010'000	\$50'953	\$0	\$0	\$1'060'953
System Converter	\$20'825	\$0	\$4'274	–\$782	\$24'317
System FC & VC	\$70'570	\$38'800	\$0	\$0	\$109'370

**Table 7** Cost Summary – Diesel Genset. (Source: Authors' elaboration)

DIESEL GENSET						
<i>Net Present Cost</i>						
Name	CAPEX	OPEX	Replacement	Salvage	Fuel	Total
Genset	\$950'000	\$6'280'000	\$6'700'000	–\$85'264	\$18'300'000	\$32'144'736
System FC & VC	\$70'570	\$38'800	\$0	\$0	\$0	\$109'370
<i>Annualized Cost</i>						
Genset	\$75'574	\$499'263	\$532'964	–\$6'783	\$1'450'000	\$2'551'018
System FC & VC	\$70'570	\$38'800	\$0	\$0	\$0	\$109'370

## Appendix B: Future Case Cost Summary

**Table 8** Cost Summary – Hybrid System. (Source Authors' elaboration)

HYBRID SYSTEM						
<i>Net Present Cost</i>						
Name	CAPEX	OPEX	Replacement	Salvage	Fuel	Total
Genset	\$760'000	\$504'426	\$158'926	−\$105'289	\$1'330'000	\$2'648'063
Li-Ion Battery	\$1'230'000	\$897'058	\$184'791	−\$33'824	\$0	\$2'278'025
PV Array	\$4'580'000	\$226'539	\$0	\$0	\$0	\$4'806'539
Converter	\$98'706	\$0	\$20'083	−\$3'676	\$0	\$115'113
System FC & VC	\$842'860	\$487'733	\$0	\$0	\$0	\$1'330'593
<i>Annualized Cost</i>						
Genset	\$60'459	\$40'128	\$12'643	−\$8'376	\$106'131	\$210'985
Li-Ion Battery	\$98'057	\$71'362	\$14'700	−\$2'691	\$0	\$181'428
PV Array	\$364'386	\$18'022	\$0	\$0	\$0	\$382'408
Converter	\$7'852	\$0	\$1'598	−\$292	\$0	\$9'158
System FC & VC	\$67'051	\$38'800	\$0	\$0	\$0	\$105'851

**Table 9** Cost Summary – PV+Battery. (Source: Authors' elaboration)

PV+BATTERY					
<i>Net Present Cost</i>					
Name	CAPEX	OPEX	Replacement Cost	Salvage	Total
Li-Ion Battery	\$3'107'165	\$465'816	\$2'261'276	−\$85'264	\$5'748'993
PV Array	\$6'625'056	\$0	\$327'658	\$0	\$6'952'714
System Converter	\$136'247	\$27'721	\$0	−\$5'074	\$158'894
System FC & VC	\$842'860	\$487'733	\$0	\$0	\$1'330'593
<i>Annualized Cost</i>					
Li-Ion Battery	\$247'180	\$37'057	\$179'889	−\$6'783	\$457'343
PV Array	\$527'035	\$0	\$26'066	\$0	\$553'101
System Converter	\$10'839	\$2'205	\$0	−\$404	\$12'640
System FC & VC	\$67'051	\$38'800	\$0	\$0	\$105'851

**Table 10** Cost Summary – Diesel Genset (Source: Authors' elaboration)

DIESEL GENSET						
<i>Net Present Cost</i>						
Name	CAPEX	OPEX	Replace- ment	Salvage	Fuel	Total
Genset	\$760'000	\$6'280'000	\$4'020'000	−\$51'158	\$18'300'000	\$29'308'842
System FC & VC	\$842'860	\$487'733	\$0	\$0	\$0	\$1'330'593
<i>Annualized Cost</i>						
Genset	\$60'459	\$499'263	\$319'778	−\$4'070	\$1'450'000	\$2'325'430
System FC & VC	\$67'051	\$38'800	\$0	\$0	\$0	\$105'851

## References

- Ahlborg, H., & Hammar, L. (2012). Drivers and barriers to rural electrification in Tanzania and Mozambique e grid-extension, off-grid, and renewable energy technologies. *RENE*, 61, 117–124. <https://doi.org/10.1016/j.renene.2012.09.057>.
- Arowolo, W., Blechinger, P., Cader, C., & Perez, Y. (2019). Seeking workable solutions to the electrification challenge in Nigeria: Minigrid. *Reverse Auctions and Institutional Adaptation*. <https://doi.org/10.1016/j.esr.2018.12.007>.
- Azimoh, C. L., Klintonberg, P., Wallin, F., Karlsson, B., & Mbohwa, C. (2016). Electricity for development: Mini-grid solution for rural electrification in South Africa. *Energy Conversion and Management*, 110, 268–277. <https://doi.org/10.1016/j.enconman.2015.12.015>.
- Eberhard, A., & Shkaratan, M. (2012). Powering Africa: Meeting the financing and reform challenges. *Energy Policy*, 42, 9–18. <https://doi.org/10.1016/j.enpol.2011.10.033>
- Economic consulting associates viewpoint mini-grids: Are cost-reflective tariffs necessary? What are the options? Economic drivers of tariff policy, 2017.
- ESMAP. (2015). Solar resource mapping in Tanzania. <http://documents.worldbank.org/curated/en/651091467986286838/pdf/96827-ESM-P145287-PUBLIC-Box391467B-WBG-ESMAP-Tanzania-Solar-Modeling-Report-2015-02.pdf>.
- ESMAP. (2019). Mini grids for half a billion people Market outlook and handbook for decision makers.
- EWURA. (2019a). Public notice on cap prices for petroleum products effective Wednesday.
- EWURA. (2019b). Public notice on cap prices for petroleum products effective Wednesday. <https://www.ewura.go.tz/wp-content/uploads/2019b/08/Cap-Prices-For-Petroleum-Products-07-August-2019-English.pdf>.
- Ghosh Banerjee, S., Malik, K., Tipping, A., Besnard, J., & Nash, J. (2017). Double dividend: Power and agriculture nexus in Sub-Saharan Africa.

- Grant Thornton. (2018). Africa renewable energy discount rate survey – 2018, no. October.
- Hittinger, E., Wiley, T., Kluza, J., & Whitacre, J. (2015). Evaluating the value of batteries in microgrid electricity systems using an improved energy systems model. *Energy Conversion and Management*, 89, 458–472. <https://doi.org/10.1016/j.enconman.2014.10.011>.
- Hoarau, Q., & Perez, Y. (2019). Network tariff design with prosumers and electromobility: Who wins, who loses? *Energy Economics*, 83, 26–39. <https://doi.org/10.1016/j.eneco.2019.05.009>.
- IEA. (2017a). WEO-2017a special report: Energy access outlook.
- IEA. (2019). [Africa\\_Energy\\_Outlook\\_2019.Pdf](#).
- IEA; IRENA; UNSD; WB; WHO. (2019). Tracking SDG 7: The energy progress report 2019.
- Lockhart, E., Li, X., Booth, S. S., Olis, D. R., Salasovich, J. A., Elsworth, J., & Lisell, L. (2019). Comparative study of techno-economics of lithium-ion and lead-acid batteries in micro-grids in Sub-Saharan Africa. <https://doi.org/10.2172/1526204>.
- Moner-Girona, M., Ghanadan, R., Solano-Peralta, M., Kougiass, I., Bódis, K., Huld, T., & Szabó, S. (2016). Adaptation of feed-in tariff for remote mini-grids: Tanzania as an illustrative case. *Renewable and Sustainable Energy Reviews*, 53(January), 306–318. <https://doi.org/10.1016/j.rser.2015.08.055>.
- Org, W., Odarno, L., Sawe, E., Swai, M., Katyega, M. J. J., & Lee, A. (2016). Accelerating mini-grid deployment in Sub-Saharan Africa: Lessons from Tanzania.
- Pavlovi, T. M., Milosavljevi, D. D., & Pirsl, D. S. (2013). Simulation of photovoltaic systems electricity generation using homer software in specific locations in Serbia. *Thermal Science*, 17(2), 333–347. <https://doi.org/10.2298/TSCII120727004P>.
- Peters, J., Sievert, M., & Toman, Michael A. (2019). Rural electrification through mini-grids: Challenges ahead. *Energy Policy*, 132, 27–31. <https://doi.org/10.1016/j.enpol.2019.05.016>.
- Reber, T., Booth, S., Cutler, D., Li, X., & Salasovich, J. (2018). Tariff considerations for micro-grids in Sub-Saharan Africa.
- Smith, K., Saxon, A., Keyser, M., Lundstrom, B., Cao, Z., & Roc, A. (2017). Life prediction model for grid-connected Li-ion battery energy storage system. In *2017 American Control Conference (ACC)* (pp. 4062–4068). IEEE. <https://doi.org/10.23919/ACC.2017.7963578>
- The United Republic of Tanzania. (2013). The United Republic of Tanzania 2012 population and housing census. [http://www.tzdpd.or.tz/fileadmin/documents/dpg\\_internal/dpg\\_working\\_groups\\_clusters/cluster\\_2/water/WSDP/Background\\_information/2012\\_Census\\_General\\_Report.pdf](http://www.tzdpd.or.tz/fileadmin/documents/dpg_internal/dpg_working_groups_clusters/cluster_2/water/WSDP/Background_information/2012_Census_General_Report.pdf).
- The United Republic of Tanzania. (2017). Energy access situation report, 2016 Tanzania Mainland' 2 (February). [https://doi.org/10.1016/S1052-3057\(16\)30617-6](https://doi.org/10.1016/S1052-3057(16)30617-6).
- Williams, N. J., Jaramillo, P., Cornell, B., Lyons-Galante, I., & Wynn, E. (2017). Load characteristics of East African microgrids. In *2017 IEEE PES PowerAfrica*, 236–41. IEEE. <https://doi.org/10.1109/PowerAfrica.2017.7991230>.
- Williams, N. J., Jaramillo, P., & Taneja, J. (2018). An investment risk assessment of micro-grid utilities for rural electrification using the stochastic techno-economic microgrid model: A case study in Rwanda. *Energy for Sustainable Development*, 42, 87–96. <https://doi.org/10.1016/j.esd.2017.09.012>.

**Open Access** This chapter is licensed under the terms of the Creative Commons Attribution 4.0 International License (<http://creativecommons.org/licenses/by/4.0/>), which permits use, sharing, adaptation, distribution and reproduction in any medium or format, as long as you give appropriate credit to the original author(s) and the source, provide a link to the Creative Commons license and indicate if changes were made.

The images or other third party material in this chapter are included in the chapter's Creative Commons license, unless indicated otherwise in a credit line to the material. If material is not included in the chapter's Creative Commons license and your intended use is not permitted by statutory regulation or exceeds the permitted use, you will need to obtain permission directly from the copyright holder.







# Establishing Local Power Markets and Enabling Financial Access to Solar Photovoltaic Technologies: Experiences in Rural Tanzania

Guglielmo Mazzà, Marco Pasini, Silvia Ricci,  
Matthew Matimbwi and Giampietro Pizzo

## Abstract

Energy inclusion is a major concern in Tanzania, where rural areas are widely lacking access to both power networks and off-grid systems. Different barriers are slowing the achievement of Sustainable Development Goal 7: universal electrification in the country raises concerns in delays and equity. Financial exclusion adds to the complexity of adopting appropriate technological solutions, particularly for rural communities. Solar photovoltaic solutions represent an opportunity to increase energy access and enable growth. The introduction of new technological products requires to establish local power

---

G. Mazzà (✉)

Microfinanza Srl, Vicenza, Italy

e-mail: [guglielmo.mazza@refuse.eco](mailto:guglielmo.mazza@refuse.eco)

M. Pasini

Associazione Microfinanza E Sviluppo ONLUS, Trento, Italy

e-mail: [marco.pasini@microfinanza.it](mailto:marco.pasini@microfinanza.it)

S. Ricci

Associazione Mazingira ODV, Trento, Italy

M. Matimbwi

Tanzania Renewable Energy Association—TAREA, Dar es Salaam, Tanzania

G. Pizzo

Microfinanza Srl, Vicenza, Italy

e-mail: [giampietro.pizzo@microfinanza.com](mailto:giampietro.pizzo@microfinanza.com)

© The Author(s) 2023

S. Groh et al. (eds.), *Electricity Access, Decarbonization, and Integration of Renewables*, Energiepolitik und Klimaschutz. Energy Policy and Climate Protection, [https://doi.org/10.1007/978-3-658-38215-5\\_11](https://doi.org/10.1007/978-3-658-38215-5_11)

263

markets, including demand, financial resources and providers, supply mechanisms and after-sale services. The financing of renewable energy solutions for rural households partially relies on microfinance institutions and community financial groups. Technology suppliers are also providing financial services to expand access to solar and photovoltaic products, applying models mostly enabled by mobile payment systems. The paper assesses the effects of an initiative implemented in Malinyi and Kilombero districts to support the establishment of local solar power markets. The involvement of Village Community Banks to engage communities and develop sustainable financial schemes is evaluated, together with the complexity of combining awareness raising on technological solutions and financial education. Results of the implementation are presented and discussed evaluating the different ingredients of the established markets.

---

**Keywords**

Financial education · Access to Finance · Renewable energy (Renewables) · Photovoltaic · Rural areas (Rural)

---

## 1 Introduction

This paper sums up the experience acquired within project “Solar Finance 4 All” (SF4A), implemented between January 2018 and April 2020 by Associazione Microfinanza e Sviluppo ONLUS (AMS) in partnership with Tanzania Renewable Energy Association (TAREA), Associazione Mazingira ODV, NADIR Onlus and MUSE—Museum of Science. The project has been financed by the Autonomous Province of Trento, in Italy. Main objective of the initiative was to establish a functional market of renewable energy technologies, including:

- Demand for Solar and Photovoltaic Technologies (SPTs).
- Financial services for ensuring access to SPTs.
- Supply mechanisms of good quality, fairly priced SPTs.
- Affordable installation and maintenance services.

SF4A contributed to the creation of a demand for SPTs, despite the efforts were hindered by the expansion of the national grid. Interest in SPTs and capacity to compare different technologies was built towards financial service providers rather than community members. The provision of SPTs through Village

Community Banks (VICOBAs) allowed to positively combine financial education and access to energy, reaching a wide population through these community-based financial providers.

The financing of solar lanterns gave positive results, with a high satisfaction and repayment rate. The external financial support provided by project partners to kick-start the provision of SPTs was fully re-collected and made available for future financing cycles. SF4A positively supported the establishment and growth of local installation and maintenance services ensuring the presence of local technicians, indispensable component for the completion of a viable market.

This paper starts with an introduction on access to energy and its linkage with financial inclusion, also assessing the presence of inclusive and community-based financial service providers. The activities implemented within the SF4A project, and the data collection methodology are presented. Results are discussed analysing the four components identified for the establishment of local markets for SPTs.

## 1.1 Access to Energy in Rural Tanzania

According to the World Bank and the Tanzanian Rural Energy Agency, access to electricity deeply divides urban and rural citizens in Tanzania, with 66% of inhabitants living outside cities, where energy is available to only 24 % of the population (REA, 2020; World Bank, 2018). The country is far from achieving universal electrification by 2030, priority highlighted by Sustainable Development Goal (SDG) 7. The Government of Tanzania is currently implementing a national energy policy, the National Rural Electrification Program (2013–2022), whose goal is to increase the country's overall electricity access of the population from 36% in 2014 to 50% by 2025 and to at least 75% by 2033 (IED, 2018).

The program, led by the Ministry of Energy and the Rural Electrification Agency includes both on-grid and off-grid solutions and has four priorities; (i) the connection of new customers to the grid in already electrified settlements; (ii) new connections to the grid; (iii) electrification through off- grid investments; and (iv) the development of distributed technologies, in particular off-grid solar and other renewable technologies (IED, 2018).

Tanzania's central grid, managed by the state public utility TANESCO, is responsible for 98% of electricity supply, counting on Independent Power Producers (IPP) and Emergency Power Producers (EPP) to provide 26% and 13% of the demand. Independent producers with a capacity inferior to 10 MW account for 2% of total capacity (WFC, 2017). The dependency from hydroelectric

systems, which supplied up to 80% of electricity needs, was hindered in recent years due to extensive droughts. This forced TANESCO to use significant load shedding, thermal power plant for base load, and hire emergency power installations, at a relevant financial cost. Hence, the energy security of the country fell, making Tanzania dependent on imported fossil fuels for its electricity (AFDB, 2015; MoEE, 2016).

This represents a heavy burden for the country's socio-economic development and energy plans. An increasing dependence on fossil sources is causing fuel price shocks, inflation and it is hindering government efforts to expand energy access due to the scarcity of financial resources. In addition, the nearly 1 million tons of charcoal consumed each year produces over 20 million tons a year in CO<sub>2</sub> emissions and requires an estimated 30 million cubic meters of wood, with annual average loss in forest cover at 100,000–125,000 hectares (AFDB, 2015). This energy supply and end use structure reflects Tanzania's low level of development and contributes to the intensification and perpetuation of poverty (WFC, 2017). Worldwide, electricity provision in rural areas no longer relies only on centralized grid expansion, but also on off-grid and mini-grid systems, differing both physically and institutionally in electricity delivery. In 2019, the share of Tanzanians connected to off-grid solar supply was 2% (IEA, 2019).

## 1.2 Energy Inclusion and Financial Inclusion Barriers

Energy inclusion in rural Tanzania is threatened by different factors including lack of access to human capital, difficulties in planning and donor dependency, low rural markets and little appeal from private sector, and finally more straightforward technical matters such as difficulties with installing electric equipment in traditional buildings (Ahlborg & Hammar, 2014). A dearth of investment is linked to the existence of excessive negative financial uncertainties or risks related to electricity infrastructures (Gregory & Sovacool, 2019), being a concurrent cause to the high exclusion rate. SDG 7 promotes access to “affordable, reliable, sustainable, modern energy” (UNDESA, 2020) but makes no attempt to track the mentioned descriptors (Moss, 2019). The existing different energy delivery systems in Tanzania raise, indeed, equity and justice concerns around how they are implemented. Electricity costs can be differently reasonable for consumers when access is provided by various technologies operated under different business models (Menghwani et al., 2020). Available data reveals that poor citizens spend up to 35% of their household income on energy while the better-off spend only 14%; even those connected to the grid opt for burning cheaper biomass to avoid

paying high electricity prices (WFC, 2017). Renewable energy solutions, and particularly SPTs, are perceived as an effective way to overcome domestic energy poverty in rural areas (Zubi et al., 2019), though financial access and effective convenience must be assessed depending on final users, technology, maturity of local SPTs markets.

According to the nationally representative survey “FinScope Tanzania 2017”, 65% of the adult population (over 16 years old) has access to either formal or informal financial services. The 14% growth of formally included people from 2013 mostly is related to transitioning from informal ones. The number of Tanzanians not having access to financial services, being formal or not, remained constant around 28% between 2013 and 2017. Rural communities are the most affected with excluded being 79% of the population (Elvis et al., 2017). The most financially excluded come from the two poorest quintiles of the population and are from rural Tanzania, where proximity to financial services is lower. They are also more likely to be people with no formal education, women, farmers, young people, and dependants (Andrew, 2013; Elvis et al., 2017; Lotto, 2018).

### 1.3 Tanzanian Microfinance and VICOBA

The Tanzanian microfinance sector services a large portion of the population who would not have access to credit and finance otherwise (Rabodiba, 2019), possibly due to inefficient incomes or unawareness (Elvis et al., 2017). With the aim of enhancing economic growth and accelerating poverty reduction, the Tanzanian Ministry of Finance and Planning (MoFP) enacted a Microfinance Act, executing the 2017 National Microfinance Policy (MoFP, 2017). The Act licenses, regulates, monitors, and supervises microfinance institutions, structuring their businesses into four tiers that reflect size, function, and potential for development:

1. Deposit-taking institutions (e.g., banks).
2. Non-deposit-taking institutions (e.g., credit providers).
3. Saving and Credit Cooperatives (SACCOs).
4. Community financial groups.

The fourth level includes Village Community Banks (VICOBA), small member-based groups mobilizing financial resources by saving and giving out loans among people within groups. Services are generally provided without any collateral, using joint liability and referees within the institution (Ahlén, 2012). VICOBA proved a success in empowering community members over the years

(Bakari et al., 2014; Nkyabonaki, 2017), partially contributing to poverty reduction (Ahlén, 2012). They differ in interest rates and repayment schedules, on a three to six months base.

According to Begasha, the main difference between the VICOBA model and the well-known Grameen model is the usage of the interest rate, which is not collected to cover lenders' operational costs while it is used to increase the capital collected, with the aim of providing bigger loans (Begasha, 2011). At the end of the cycle the interest rate is usually divided between the members together with savings sharing with them the increase of capital. VICOBA's differ from minimum and maximum amount of savings and loans, how loans can be linked to shares and how often group members divide the money among participants (Ahlén, 2012).

## 1.4 Financing SPTs in Rural Tanzania

Energy financing by financial institutions towards Micro, Small, Medium Enterprises was a sector at infancy before this decade, with most of the end user finance in the energy sector being for solar lanterns (SLs) or solar home systems (SHS), generally for domestic use (Kariuki & Rai, 2010). In Tanzania, Renewable technologies suppliers themselves offer targeted financial services to expand access to SPTs, hindered in the past by high costs of technologies combined with low purchasing power (Kassenga, 2008). An example is the Pay as You Go (PAYG) model, where an energy service provider rents or sells SPTs in exchange for regular payments through mobile payment systems; in cases of non-payment, the service provider can remotely disconnect the service (IRENA, 2020). Several positive aspects enabled the expansion of the sector, including consumer awareness of PAYG models (IRENA, 2020), remote monitoring and control (Mazzoni, 2019), and eased incremental repayments allowing access for poor households (USAID, 2017). Nonetheless, negative factors must be considered. There is a wide range of standardised products and solutions (Energylopedia, 2016), possibly not covering tailored needs and making SPTs only complementary to other energy sources (Collings & Munyehirwe, 2016). Customers lack education about the capabilities of the products (Collings & Munyehirwe, 2016), and technical faults are often untackled due to distances or absence of technicians, due to the highly sales-oriented model adopted by PAYG companies (Naqvi & Bhatt, 2019).

To increase their profit, suppliers often deliver inappropriate low-quality products at a high service cost, aiming to expand their sales at the expense of clients. (Naqvi & Bhatt, 2019). Finally, as mentioned by D. Waldron and A.M. Sinderen, the rapid emergence of remote lockout technology in lending raises important

difficult questions (Waldron & Swinderen, 2018): When is it appropriate to disable a financed asset? What balance must be struck between borrowers' dignity and lenders' need for security?

---

## **2 Intervention Methodology and Implementation**

Seen the need for improving energy inclusion in rural Tanzania, combined with the necessity to fund access to energy solutions, the intervention implemented by AMS contributed to the establishment of the different ingredients that ground solar power markets in villages, directly working in rural areas in Malinyi and Kilombero districts, Morogoro Region. The envisioned methodology grounds on combining social, technological, and financial aspects to generate a viable system of demand and provision of SPTs as well as technicians and financial providers.

### **2.1 Project Stakeholders**

Through participatory initiatives, SF4A engaged the different stakeholders, assessing their diverse needs related to their status and interests. The target local community, residing in the eight villages of Misegesi, Kipingo, Lugala, Igawa, Mang'ula A e B, Mwaya e Mgudeni, has been involved together with local authorities, public and private institutions, and associations active in the area. A group of 36 VICOBAs has been selected as local financial provider, the local partner TAREA has been involved in the process acting as a supply chain linkage together with local retailers. In Kilombero, 7 technicians have joined the initiative and 5 had been previously involved in Malinyi.

### **2.2 Theory of Change**

SF4A combines the socio-cultural factors related to the demand of SPTs, depending on financial capabilities, understanding of solar and photovoltaic solutions as well as community engagement that ground the market of these products. The aim was to establish a viable network of stakeholders composing a solar market, able to identify, purchase, sell, finance, install and maintain SPTs in rural areas. The expected impact of the initiative was the enhancement of the economic, social, and environmental capital of the area, contributing to the sustainable development of the region. To achieve this, SF4A provided training and technical

assistance together with capital, while working with the different stakeholders to approach the achievement of the expected long-term result. The envisioned theory of change highlights the process that leads from target stakeholders to direct outputs of the activities conducted and to the outcomes in the short and medium term, potential indicators of the contribution to the expected long-term impact, see also Table 1. Hence, the intervention methodology implies the development of four complementary components functional to the creation of a sustainable enduring mechanism. The components, highlighted in Table 1, include:

- Awareness raising on SPTs, communities and local authorities engagement.
- Financial education, at family and financial provider level (prioritization of savings principles).
- Innovative financial mechanisms for SPTs: rotative funds.
- After-sale services for SPTs.

**Table 1** Theory of change: expected outputs (OPs) and outcomes (OCs) of SF4A project activities in Malinyi and Kilombero, disaggregated by type of activity and targeted group. (Source Authors' elaboration)

Target	Activities	Outputs	Short Term OCs	Medium Term OCs
Local community	Awareness raising	Community aware of benefits of SPTs and difference between good/bad quality SPTs	Community understanding and demanding SPTs	Established demand for SPT products and services
VICOBA's members	Financial Education	Usage of Savings notebooks, provision, and reimbursement of solar lanterns	First financial service piloted	Financial services for SPTs made available
VICOBA's, TAREA, retailers	Technical Assistance	Selection, purchase, seed funding of good quality SPTs	Supply channel of good quality SPTs piloted	Access to good quality SPTs through local retailers
Local Technicians	Technical Assistance	Development of local technicians' skills and incorporation of a cooperative	Piloting of services for SPTs' adopters	Affordable installation/maintenance services available



### 2.3 Data Collection Methodology

Through qualitative semi-structured questionnaires and quantitative data collection tools, baseline data for the intervention were collected. Surveys were conducted in Swahili language by local trained operators. With the aim of understanding the stakeholder's status and developing tailored initiatives, the baseline provided data for tracking the achievement of expected outcomes and behavioural changes. Monitoring indicators and research questions were, though, not as structured and organized in the initial phase compared to the final evaluation, due to the inability to foresee project variations, unexpected changes in the environment as well as varied priorities and updated expectations. The initial assessment conducted focused on:

- Appraising access to energy sources and SPTs.
- Evaluating local financial behaviours, family budgets, in particular on energy-related expenditures.
- Understanding the functioning of local financial providers, in particular VICO-BAs.

The final evaluation of the initiative assessed the appreciation, usage of SPTs and related services, local community members' progress and the enhancement of the local solar market. The evaluation also included a final survey with 199 qualitative interviews conducted towards VICOBAs' leaders, their members who did and did not purchase SPTs, community members not joining VICOBAs. Six evaluation sections were included in the questionnaire to evaluate:

- Respondents' situation (e.g., poverty level, work).
- Knowledge of and access to SPTs.
- Appreciation of financing method and usage of SPTs.
- Access to and usage of financial services.
- Family budget management (for trained people).
- Activities and performance of VICOBAs (for leaders).

The Poverty Probability Index analysis of project beneficiaries highlighted that the poverty rate of the target community is in line with rural Tanzania levels, and that the financial situation of VICOBAs' members is comparable to the one of non-members. Working with such local financial providers is therefore an effective way to target a population representative of the reference community, and a way to achieve multiplier effects.

## 2.4 Activities Implemented and Financial Scheme Established

The SF4A project has been implemented over a period of two years, started in February 2018. Initiatives realized through SF4A, apart from coordination and management related activities, include:

- 2 awareness events on SPTs (600+ participants).
- 3 demonstrative installations of photovoltaic systems.
- 4 demonstrative provisions of photovoltaic systems to local entrepreneurs for productive activities.
- 36 VICOBAAs identified, 2 financial education cycles provided to 3 leaders of each, financial education sessions provided to members.
- 1 rotative fund for SPTs financing established.
- 30 VICOBAAs involved in SPTs financing.
- 7 technicians trained and supported in incorporating a viable service cooperative.
- 1 training program for SPTs retailers.

The provision of technical assistance allowed the establishment of a rotative mechanism for SPTs supplies and delivery, kick-started along with a seed financial injection. The mechanism allows TAREA, Tanzanian non-profit promoter of renewable energies, to negotiate large quantities of high quality SPTs under favourable market conditions. SPTs are then provided to VICOBAAs, depending on orders placed by their members. VICOBAAs provide the reserved SPTs, managing the monthly recollection of expenditures and withholding a quota as expenditures cover, revenue source and first year guarantee. VICOBAAs then refund TAREA of both purchasing and transportation costs. The process allows the supply of selected SPTs with an advantageous quality- price rate. Once expenditures are covered, collected funds can be reallocated to new financing cycles. VICOBAAs' margins can be redistributed either as services or as shared profit between all contributors at the closure of the saving scheme cycle. Through a participatory methodology, SF4A worked together with VICOBAAs' representatives and TAREA on the definition of appropriate prices related to the adoption of SPTs, being solar lamps or solar home systems (including photovoltaic panels, batteries, basic home grids). Technologies, costs, delivery, reimbursement rules and profit share were discussed and agreed by and with them.

### **3 Results**

Outputs and outcomes of the initiative are presented and discussed according to the adopted theory of change, to assess the progress towards expected results and to evaluate unforeseen effects and findings. Four results sections follow.

#### **3.1 SPTs Awareness**

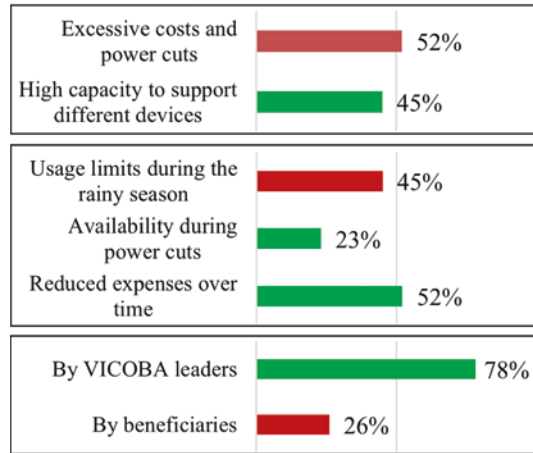
The engagement of community leaders of public and private institutions at Village, Ward, District level successfully matched the participation of residents, both involved in awareness initiatives and SPTs' demonstrative installations, in both community spaces as well as private enterprises. Installations benefited more than 3 buildings with 1000+beneficiaries and 4 small entrepreneurial activities. The interest in SPTs was limited due to a direct competition with the expansion of the TANESCO grid, preferred by 45% of respondents. Connecting to the grid is positively perceived because of being powerful enough to support different devices (45%), while it is dispraised for being too expensive or subject to power cuts (53%). More than half of the respondents' value SPTs as less expensive because of only being tied to an initial investment (52%) and for being available even in case of power-cuts (23%). 45% of respondents, though, fear usage issues during the rainy season. When assessing the differences between analogous SPTs, 26% of interviewees highlight huge differences, while 33% notice only slight dissimilarities. Results are presented in Fig. 1.

The goal of building the capacity to evaluate SPTs depending on their quality was not reached as hoped. 74% of the sample stated they are not able to identify good and bad solar. Although, the result was achieved with suppliers and local technicians, and only 22% of VICOBA's leaders state that no differences can be noticed between similar technologies, suggesting that financial providers can guide the adoption of selected solar and photovoltaic products.

#### **3.2 Community Members' Financial Education and Engagement**

SF4A invested in enhancing financial capabilities of both VICOBA's leaders and members, with a particular focus on enhancing effective resources management to increase access to and usage of sustainable energy sources. Training has been

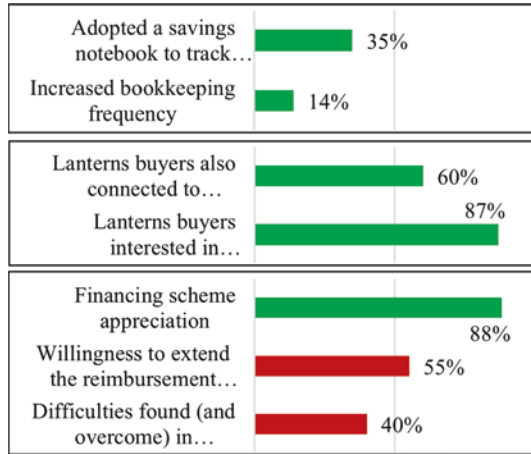
**Fig. 1** Evaluation of SF4A awareness project components (positive in green, negative in red). (a)—Appreciation of TANESCO National Grid. (b)—Appreciation of SPTs. (c)—Capacity to compare different SPTs and assess their quality. (Source: Authors' elaboration)



delivered to financial institutions' leaders (presidents, secretaries, treasurers of 36 VICOBA) who then trained their participants (for a total of over 700 associates). 100% of committee members positively evaluated the benefits of the training. The percentage falls to 66% within members, denoting that VICOBA's leaders are a good information channel though their capacity to transfer knowledge can be improved. Financial education on family budget management and savings generation helped 80% of participants in changing their behaviours, starting to track expenditures (39%), or increasing their bookkeeping frequency 14%. Indirectly, training success can be evaluated through the adoption of the tool provided for basic accounting; the tailored saving notebook developed has been tested by 80% of trainees and permanently adopted by 35%, apparently a limited result but a significant fraction basing on similar experiences. The practical saving exercises conducted, which were positively valued by 36% of interviewees, and the assessment of energy related expenditures were strongly correlated within the training on SPTs. Results are presented in Fig. 2.

553 people decided to purchase a SL (going beyond the initial objective of 400 adopters). Out of the surveyed members who got a lantern, 80% appreciate the product, mostly because of its light quality, portability, fair price. SLs were mostly acquired by members who already had access to the hydroelectric grid (60%), highlighting the benefits of blended solutions in relation with grid-related problems. Negative feedback registered highlights that SLs were not able to illuminate the entire household and that some VICOBA's members would have pre-

**Fig. 2** Evaluation of SF4A financial inclusion for energy access project components (positive in green, negative in red). (a)—Behavioural change in household budget management. (b)—Blended solutions usage and interest. (c)—Financing schemes benefits and limits. (Source Authors' elaboration)



ferred to directly adopt a higher scale SHS. In fact, 87% of buyers declared to be interested in purchasing a SHS for their home, mentioning difficulties in both identifying products (44%) and having the needed financial resources (43%). This result underlines the importance of the facilitation role guaranteed by local financial providers.

SLs were mostly used to illuminate the main room of the household (96%), to light the shelter close to their crops (83%), to allow kids studying when it gets dark (75%), to charge phones (76%), and to illuminate the workplace (11%). Most buyers appreciated the reimbursement scheme introduced by VICOBA (88%), defined beneficial but improvable by 9% of respondents and criticized by 3% only. The totality of SL purchasers who did not appreciate the product were though satisfied of the reimbursement scheme. Aspects that the community would improve include extending the reimbursement period (50%), reducing the final price (22%). While 60% of purchasers acquired the SL without problems, 40% have found (and overcome) some difficulties, mostly related to the duration of the repayment cycle.

### 3.3 SPTs Financing and Supply Chain

A demand for SPTs has been proven even in areas served by the national grid, as substitutes or complementary. SLs are not the only product requested, 83.7% of respondents are interested in SHSs, even if financial access is not possible for all. The final evaluation registered an increased demand, within VICOBA's members

and non-members who contacted project partners. The willingness of purchasing SLs in cash highlights a market for local retailers and technicians. SPTs availability has increased since the beginning of the implementation, and targeted trainings have been provided to local retailers, representing a strategic communication channel.

The financing scheme adopted for SLs has proven to be effective. The five financing cycles implemented closed with a 97.5% repayment rate, meaning that only 2.5% of purchasers were not able to reimburse the product. The rotative fund established is therefore a viable and well understood mechanism that partners can extend to future financing cycles in the long term. The scheme allowed a multiplier effect generating 1.73 the value of each Tanzanian Shilling invested. The counter-value was therefore made available for the beneficiary community, meaning that SLs have been provided for a value 1.73 times higher than the initial capital allocated.

Prior to the end of the initiative, the financial conditions for financing SHS were defined, a bank account was established for the capitalization of a fund and products have been presented to community members. VICOBA's financial stability and capitalization is still a restrictive factor, to be possibly partially mitigated through further education on savings generation. SHSs remain barely accessible for households, while representing a promising opportunity for entrepreneurial activities. The initiative registered an initial request of 39 SHSs, reasonably lower than the 553 SLs distributed.

### **3.4 After Sale Services**

Installation and maintenance services are available and fairly priced in the area. SF4A allowed the reinforcement of the existing cooperative of technicians AMBASE, established in Malinyi district, through a previous initiative by AMS also funded by the Autonomous Province of Trento. The cooperative is effective and growing, reaching a capital exceeding 4,000,000 Tanzanian Shillings over two years. The equivalent of 1,500 USD, around 300 USD for each of its five members, is a significant amount in a country in which the Gross National Income per capita was around 1,080 USD/year in 2019 (World Bank, 2019). In Kilombero district, 7 technicians were trained, resulting in the incorporation of ANGAZA cooperative, which opened a bank account and established its office. The cooperative became operational and positively concluded 6 interventions before the end of the initiative. Upon the 40 VICOBA's members who received services from the two cooperatives, over 80% of interviewees confirmed they

were satisfied with the interventions, the remaining ones affirmed it was at standard level and no one criticized their work.

### **3.5 Threats: Environmental Factors and Covid-19**

External factors had an unforeseen effect on the initiative. Intense rainfall seasons posed an important threat, with Malinyi district remaining isolated for over three months in 2018 and 2020. A drought in 2019, as well as heavy precipitations in 2020 affected agricultural production, main source of income for most of the beneficiaries. Significantly reducing their saving capacity, economic investments were hindered. Though 41% of SL buyers stated they did not encounter any problem, the first distribution unrolled during the rainy season. Stakeholders therefore agreed to delay the repayment phase, avoiding late reimbursements or insolvency. The flexibility of the financial mechanisms is therefore capable to match the need to combine resources planning, climate hazards and related debts.

Environmental threats particularly affected the adoption of SHSs, for which interested buyers preferred to delay the acquisition. Losses, combined with unforeseen damage remediation expenditures, affected the purchase of SHSs, which had been planned at the end of the agricultural cycle in both early 2019 and early 2020. Adding to this, the COVID-19 Pandemic affected the adoption of energy systems. SHSs, in fact, had been selected based on their quality from European and Indian companies, while in any case most spare components are made in China, and were therefore not available on the market. The distribution has been interrupted and will be carried out with the support of TAREA when possible.

---

## **4 Conclusion**

SPTs represent a valuable opportunity to diversify energy access in rural areas, both where villages are reached by electrical grids and in unconnected communities. Even with the positive results obtained with project SF4A, access to appropriate good quality technologies and products remains a barrier for rural communities.

The initiative highlighted, in fact, the potential of introducing small scale SLs able to provide a source of light or charge small appliances. SLs, though, cannot cover the needs of an entire household, and remain bounded to weather conditions and product reliability. The limited benefit of this device cannot sustain the

behavioural change possibly related to accessing electricity, and willingness to expand its usage for different uses. SHSs, on the other hand, are still too expensive, not allowing most community members to cover the initial sum needed for the investment. SHSs are more appropriate to cover growing electricity needs, however it would still bound households to the presence of the sun, in a country where the rainy season is yearly expected for three months.

The financing mechanism can be flexible enough to delay reimbursements in case of external threats, but it is unable to cover the diversified needs of community members with different financial resources and capabilities. VICOBAAs, in fact, proved to gather a wide range of adherents, including landowners, farmers, employees, entrepreneurs and more. Their diverse needs are not addressed with different financial products or conditions. The price of SPTs and the investment capacity leads to different levels of access, with only wealthier members reaching products able to guarantee a satisfactory energy access. VICOBAAs' growth capacity is bound to their functioning mechanisms, which limits a permanent capitalization of these financial institutions. Dividing shares between members at the end of every cycle means that VICOBAAs can generate value and growth but cannot stabilize and increase their resources ensuring longer term sustainability. A direct issue, for instance, is allowing large scale investments for the community, having portfolios unable to scale compared to amounts saved by the community. This means that future greater financial opportunities, and in this case large scale adoption of appropriate SPTs, can be difficult.

The value of this intervention remains relevant. Possible future initiatives must evaluate how to improve the defeat of both financial and technological barriers, possibly focusing on different solutions in terms of financial schemes and renewable energy sources, always considering how to assemble all collateral components of local power markets.

---

## References

- African Development Bank Group (AFDB). (2021). *Tanzania: Country profile*. Technical report.
- Ahlborg, H., & Hammar, L. (2014). Drivers and barriers to rural electrification in Tanzania and Mozambique – grid- extension, off-grid, and renewable energy technologies. *Renewable Energy*, 61, 117–124. World Renewable Energy Congress – Sweden, 8–13 May 2011.
- Ahlén, M., Loiske, V-M. & Lindberg, C. (2012). *Rural member-based microfinance institutions: A field study assessing the impacts of Saccos and Vicoba in Babati district, Tanzania*. Södertörn University. School of Life Sciences. <http://www.diva-portal.org/smash/get/diva2:544512/FULLTEXT01.pdf>.



- Andrew, D. (2013). *Causes of financial exclusion in Tanzania*. PhD thesis, University of Dar es Salaam, Dar es Salaam.
- Bakari, V., Magesa, R., & Akidda, S. (2014). *Mushrooming village community banks in Tanzania: Is it really making a difference?* Citeseer.
- Begasha, N. (2011). *Vicoba vs. underdevelopment syndrome - explanations for the inability to save one's way out of poverty*. Master's thesis, Uppsala University, Uppsala.
- Collings, S., & Munyehirwe, A. (2016). Pay-as-you-go solar pv in Rwanda: Evidence of benefits to users and issues of affordability. *Field Actions Science Reports (Special Issue 15, Online since 07 October 2016)*. <https://journals.openedition.org/factsreports/4189>. Accessed: 10 Feb. 2021.
- Elvis, M., Irma, G., Julia, S., & Sosthenes, K. (2017). *FinScope Tanzania 2017 - Insights that drive innovation*. Technical report, FinScope Tanzania 2017 Steering Committee, Ipsos Tanzania, Yakini Development Consulting.
- Energypedia. (2016). *Fee-For-Service or Pay-As-You-Go Concepts for Photovoltaic Systems*. Technical report, Energypedia, the wiki platform for collaborative knowledge exchange on renewable energy, energy access, and energy efficiency topics in developing countries. Last Updated in 2016. Connection on 10 February 2021.
- Gregory, J., & Sovacool, B. K. (2019). The financial risks and barriers to electricity infrastructure in Kenya, Tanzania, and Mozambique: A critical and systematic review of the academic literature. *Energy Policy*, 125, 145–153.
- International Energy Agency (IEA). (2019). *Tracking SDG 7: The Energy Progress Report 2019*. Technical report, International Energy Agency (IEA), International Renewable Energy Agency (IRENA), United Nations Statistics Division (UNSD), World Bank Group (WB), World Health Organization (WHO) - Washington DC.
- Innovation Energie Développement (IED). (2018). *United Republic of Tanzania - National Electrification Program Prospectus*. Technical report.
- International Renewable Energy Agency (IRENA). (2020). *Innovation landscape brief: Pay-as-you-go models*. Technical report, Abu Dhabi.
- Kariuki, P., & Rai, K. (2010). *Market survey on possible co-operation with Finance Institutions for Energy Financing in Kenya, Uganda, and Tanzania*. Technical report, GEVP International. Financed by the United States Agency for International Development (USAID).
- Kassenga, G. R. (2008). The status and constraints of solar photovoltaic energy development in Tanzania. *Energy Sources, Part b: Economics, Planning, and Policy*, 3(4), 420–432.
- Lotto, J. (2018). Examination of the status of financial inclusion and its determinants in Tanzania. *Sustainability*, 10(8), 2873.
- Mazzoni, D. (2019). *Digitalization for energy access in Sub-Saharan Africa: Challenges, opportunities and potential business models*. Technical report, Fondazione Eni Enrico Mattei.
- Menghwani, V., Zerriffi, H., Korkovelos, A., Khavari, B., Sahlberg, A., Howells, M., & Mentis, D. (2020). Planning with justice: Using spatial modelling to incorporate justice in electricity pricing – the case of Tanzania. *Applied Energy*, 264, 114749.
- Ministry of Energy and Minerals, United Republic of Tanzania (MoEE). (2016). *The Draft National Energy Policy 2015*. Technical report.
- Ministry of Finance and Planning, United Republic of Tanzania (MoFP). (2017). *National microfinance policy 2017 implementation strategy for the period 2017/18–2027/28*. Technical report.

- Moss, T. (2019). *Ending global energy poverty - how can we do better?* Technical report, World Economic Forum.
- Naqvi, B., & Bhatt, R. (2019). Stepping back: Product, collections and credit risk in PAYGo solar. *Financial Inclusion and Energy Blog Series*. Technical report, CGAP.
- Nkyabonaki, J. (2017). Village community banks (VICOBA) in socioeconomic development in Tanzania: The only game in town? A case of selected areas in Dar Es Salaam. *International Journal of Technology and Management*, 2(2), 11–11.
- Rabodiba, V. (2019). *Introduction of a new Microfinance Act in Tanzania: What impact will it have on the housing sector?* Technical report, Centre for Affordable Housing in Africa (CAHF).
- Tanzania Rural Energy Agency (REA). (2020). *Energy access and use situation survey II in Tanzania Mainland*. Technical report.
- United Nations Department of Economic and Social Affairs (UNDESA). (2020). *The Sustainable development goals report 2020*. Technical report.
- USAID Global Development Lab Center for Digital Development Strategy and Research. (2017). *Pay-As-You-Go solar as a driver of financial inclusion*. Technical report.
- Waldron, D., & Swinderen, A. M. (2018). Remote lockouts: The Dark side of Pay-as-You-Go Solar? *Financial Inclusion and Energy Blog Series*. Technical report, CGAP.
- World Bank. (2018). *Sustainable energy for all (SE4ALL) database from the SE4ALL global tracking framework*. Technical report, World Bank, International Energy Agency, and the Energy Sector Management Assistance Program.
- World Bank. (2019). *GNI per capita, atlas method (current US\$)*. Technical report, World Bank national accounts data. The World Bank Group.
- World Future Council (WFC). (2017). *Policy roadmap for 100% renewable energy and poverty eradication in Tanzania*. Technical report, World Future Council, Brot Für die Welt, Climate Action Network Tanzania.
- Zubi, G., Fracastoro, G. V., Lujano-Rojas, J. M., El Bakari, K., & Andrews, D. (2019). The unlocked potential of solar home systems; an effective way to overcome domestic energy poverty in developing regions. *Renewable Energy*, 132, 1425–1435.

**Open Access** This chapter is licensed under the terms of the Creative Commons Attribution 4.0 International License (<http://creativecommons.org/licenses/by/4.0/>), which permits use, sharing, adaptation, distribution and reproduction in any medium or format, as long as you give appropriate credit to the original author(s) and the source, provide a link to the Creative Commons license and indicate if changes were made.

The images or other third party material in this chapter are included in the chapter's Creative Commons license, unless indicated otherwise in a credit line to the material. If material is not included in the chapter's Creative Commons license and your intended use is not permitted by statutory regulation or exceeds the permitted use, you will need to obtain permission directly from the copyright holder.

